

TYPICAL

CYLINDER BED COMPOUND FEED SEWING
MACHINE WITH LARGE ROTARY HOOK



TW3-341

TYPICAL SEWING MACHINE WANPING MACHINERY CO.,LTD.

CONTENTS

Operation instruction

1. Brief instruction.....	1
2. Main specifications.....	1
3. Operation preparation.....	1
4. Installing the knee lifter mechanism.....	1
5. Lubrication.....	2
6. Installing the thread stand.....	2
7. Installing the belt cover and bobbin winder.....	3
8. Installing the needle.....	3
9. Installig the bobbin case.....	4
10. Winding the bobbin thread.....	4
11. Put the bobbin into bobbin case.....	4
12. Threading the needle thread.....	5
13. Adjusting the stitch length.....	5
14. Thread tension.....	5
15. Thread take-up spring.....	6
16. Adjusting the pressure of presser foot.....	6
17. Adjusting the height of presser foot.....	6
18. Adjusting the height of feed dog.....	7
19. Adjusting the needle and hook.....	7
20. Adjusting the needle guard plate.....	8
21. Adjusting the inner hook guide.....	8
22. Adjusting the lengthways position of needle bar frame.....	8
23. Safety clutch device.....	9
24. Reloading the timing belt.....	9
25. Trouble and remedy.....	10

Parts list

1. Casting components.....	11-12
2. Upper shaft and thread take-up lever components.....	13-14
3. Needle bar and hook driving shaft components.....	15-16
4. Presser foot components.....	17-18
5. Upper feed mechanism components.....	19-20
6. Lower feed mechanism components.....	21-22
7. Thread tension components.....	23-24
8. Belt cover and bobbin winder components.....	25-26
9. Knee lifter components.....	27-28
10. Accessories.....	29-30

OPERATION INSTRUCTION

1. Brief introduction

TW3-341 cylinder bed sewing machine adopts single needle, slide type thread take-up lever, and vertical large hook. Upper and lower shafts are driven by synchronized toothed belt. Compound feed by feed dog, needle and walking foot; and high presser foot stroke and lifter assure its high sewing heavy ability and easy for sewing multi-layer leather and materials. Safety clutch device also assures safe operation

It's widely used for sewing leather products, suitcases, shoes and caps. Especially, its cylinder bed is suitable for sewing various arc and curved materials.

2. Main specification

Max. sewing speed	2000s.p.m
Max. stitch length	6mm
Needle bar stroke	33.36mm
Presser foot lift height	6.5mm by hand 15mm by knee
Thread take-up lever	Slide type
Hook	Large hook
Needle	DP × 17 14°~24° (standard 23°)
Lubrication	Oiled by hand
Motor power	400W (special for sewing machine 2P)
Application	Medium, heavy, extra heavy weight materials

3. Operation preparation

- Before first operate the machine, please clean the machine thoroughly in order to weed out the dust and fully lubricate the machine.
- Please confirm if the voltage will be used is suitable for the design voltage.
- The rotating direction of the machine is counter-clockwise when observed face to the hand wheel.
- Before turn over the machine head, please take down the knee lifter chain hook.
- When trial running, please take down the bobbin and needle.
- Please control the sewing speed under 1800s.p.m within the first operation month.
- Only after the machine stops, then the hand wheel can be operated.

4. Installing the knee lifter mechanism (Fig.1)

When use the knee lifter pedal, please use the screw ② to fix the knee lifter lever ①.

Knee lifter lever ① and screw ② are packed in the accessory carton.

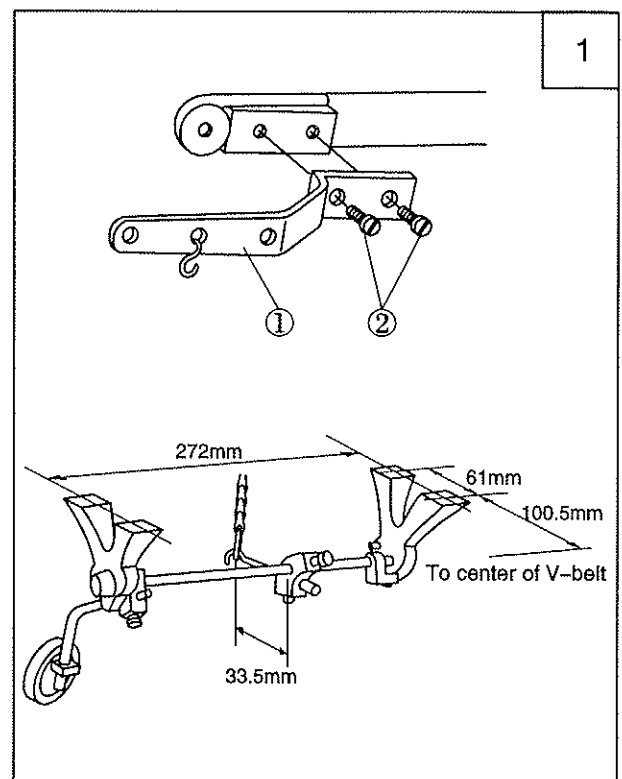

5. Lubrication (Fig.2)

1. Before running, please fill the oil at the places as arrow shown.
2. Lubricating the hook and hook shaft saddle.
Move the bed slide, fill the oil into the hole A two or three drops every day, fill the oil into the felt B four or five drops.
3. Lubricating the feed lever
Before running, please fill the oil into holes C, D, E two or three drops.

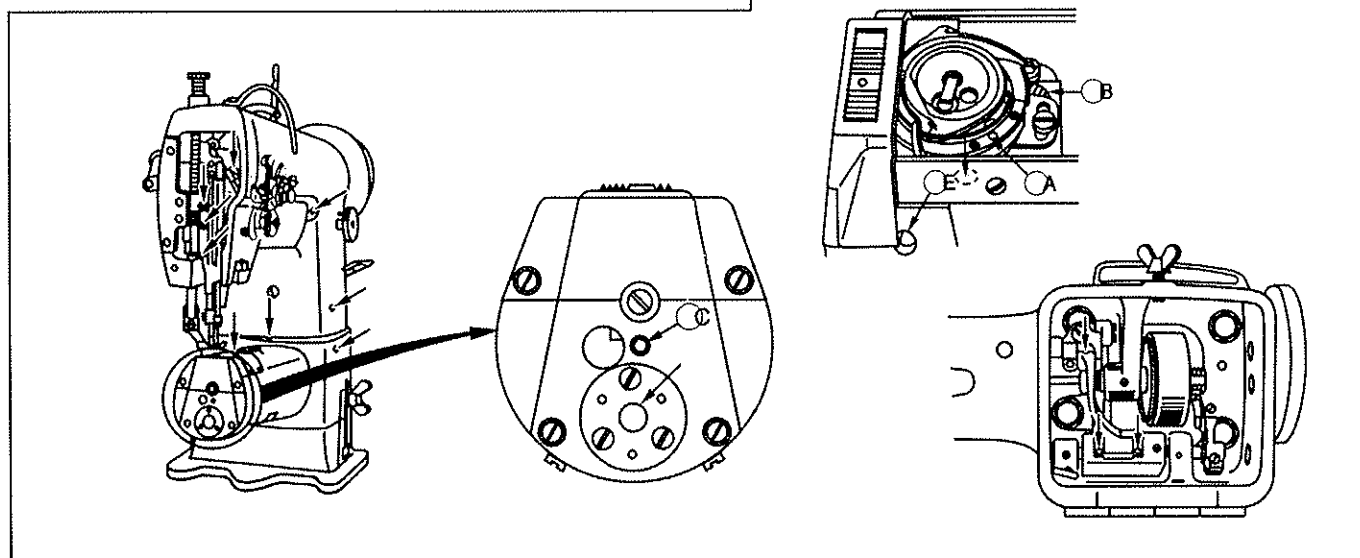

6. Installing the thread stand (Fig.3)

The thread stand should be located on the right backside of the table, then tighten the nut C.

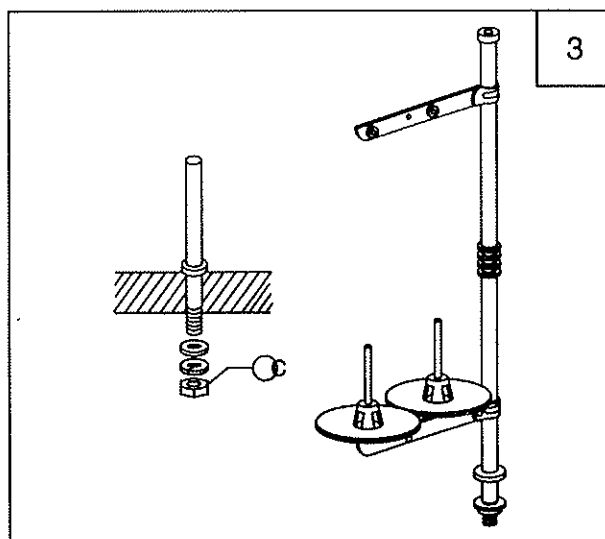

7. Installing the belt cover and bobbin winder (Fig.4、 5)

1. Install the belt cover support column ① into the screw hole;
2. Install the belt cover support plate ② on the machine casting;
3. Install the belt cover ③ on the belt cover support column ① and the belt cover support plate ②;
4. Install the bobbin winder ⑥ into the cover ③ and adjust it to the proper position;
5. Fix the bobbin winder ⑥ on the table;
6. Install the V-belt on the hand wheel, then install the belt cover ④ and belt cover ⑤.

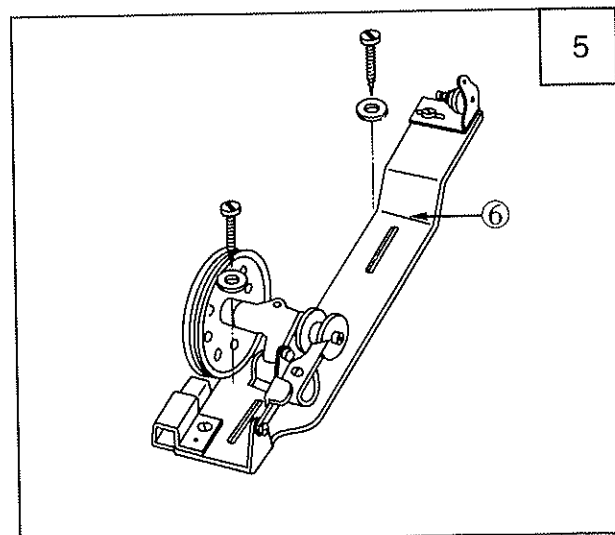
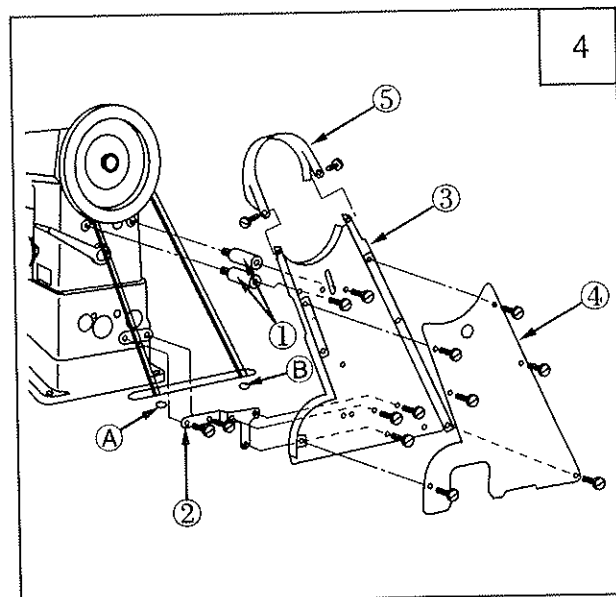

8. Installing the needle (Fig.6)

1. Turn off the power;
2. Turn the hand wheel to lift the needle bar to its highest position;
3. Loosen the needle set screw ②, and make the needle ① groove A to the right side;
4. Insert the needle shank until to the bottom of the needle bar socket;
5. Tighten the screw ②.

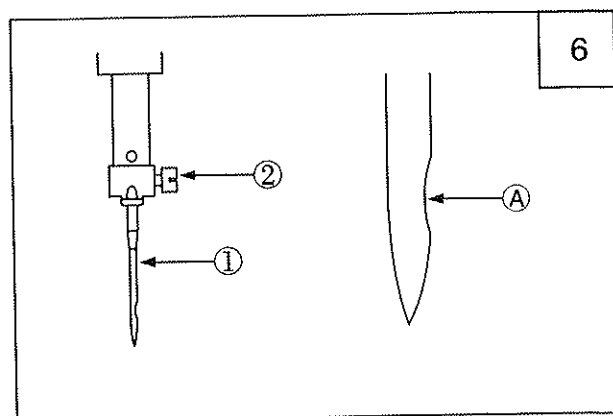

9. Installing the bobbin case (Fig.7)

1. Open the hook opener, put the bobbin and bobbin case into the hook;
2. Put the bobbin case on the hook driving shaft, then lay down the hook opener.

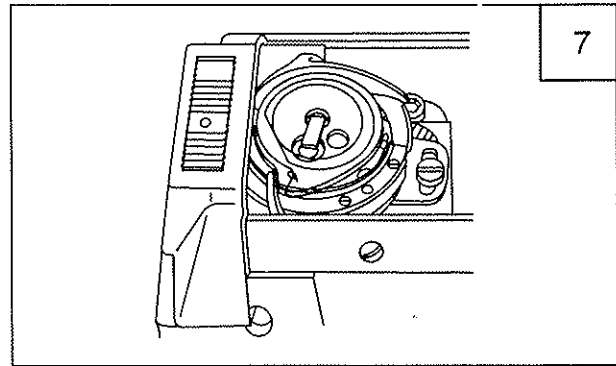

10. Winding the bobbin thread (Fig.8)

1. Threading the thread as following order A, B, C, then wind the thread around bobbin several circles;
2. Press down the bobbin press plate ①, the winding pulley will be touched with the V-belt;
3. Winding amount can be adjusted by the screw ②, the optimum capacity of bobbin thread is fill about 80% of bobbin outside diameter. Turn the screw clockwise to increase the winding amount, contrary, to decrease the amount;
4. If the thread is not neat, please move the bracket ③ to adjust it;
5. When the winding is over, the bobbin press plate ① will be loose and the bobbin winder will stop automatically.

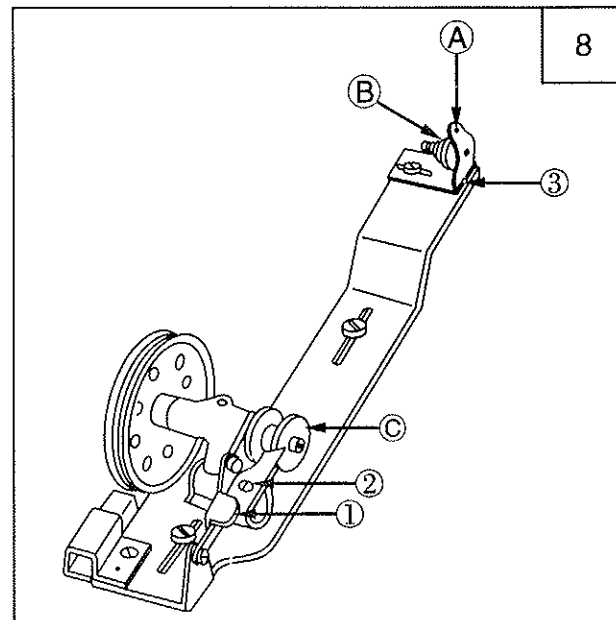

11. Put the bobbin into bobbin case (Fig.9)

1. Draw the tip of bobbin thread to the right, then put the bobbin into bobbin case;
 2. Draw the bobbin thread through the slit ① on the bobbin case, then pass through the thread tension spring, finally, draw the thread out of the slit ②.
- Reminder: if the bobbin is put correctly, when draw the bobbin thread as A shown, the bobbin will rotate as B shown.

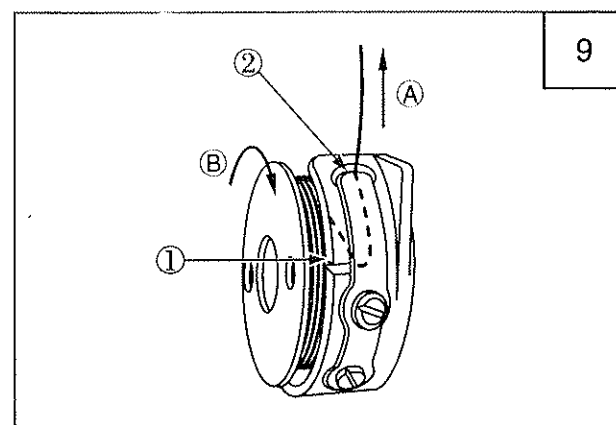

12. Threading the needle thread (Fig. 10)

When threading, the needle bar should be on its highest position, then threading the thread from the thread stand and threading as shown order according to Fig.10.

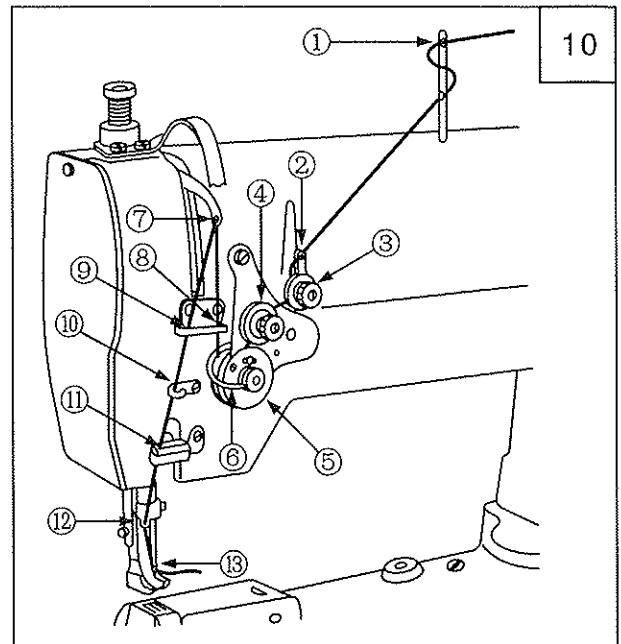

13. Adjusting the stitch length (Fig. 11)

Turn the stitch dial counter-clockwise or clockwise to adjust the stitch length. The figure on the dial is the stitch length.

1. Press the feed lever ② downward;
2. When press the feed lever downward, the feeding is reverse;
3. Release the feed lever, the machine recovers normal feeding again.

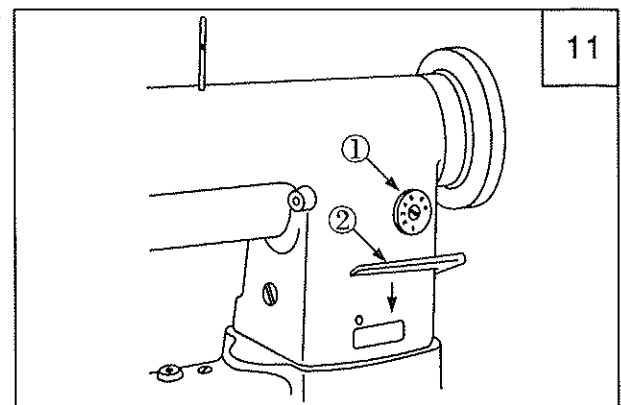

14. Thread tension (Fig. 12)

1. Adjusting the tension of needle thread

Turn the tension adjustment nut ① clockwise (A direction) to increase the tension of needle thread; turn the nut counter-clockwise (B direction) to decrease the tension.

2. Adjusting the tension of bobbin thread

Turn the tension adjustment nut ② clockwise (C direction) to increase the tension of bobbin thread; turn the nut counter-clockwise (D direction) to decrease the tension.

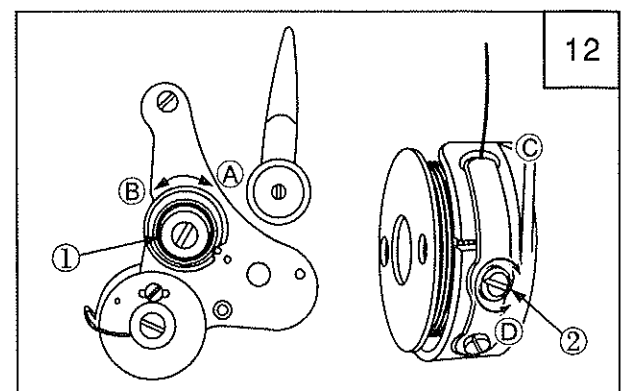

15.Thread take-up spring (Fig.13)

1. Adjusting the thread take-up spring ① stroke
 - a. Loosen the screw ②, and move the disc ③ leftward or rightward;
 - b. Move the disc rightward to increase the spring stroke, contrary, to decrease the spring stroke.
2. Adjusting the tension of thread take-up spring
Tighten the nut ④, turn the spring shaft counter-clockwise to increase the tension, contrary, to decrease the tension. Please use a screwdriver to rotate the spring shaft ⑤ to get the required tension.

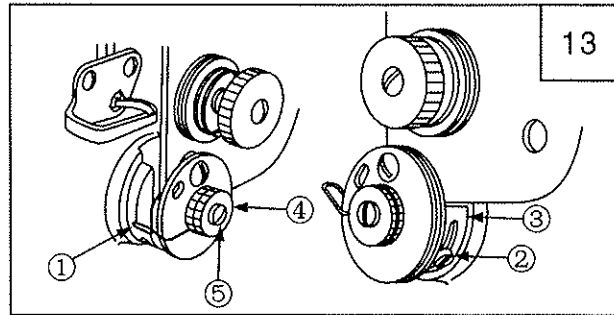

16.Adjusting the pressure of presser foot (Fig.14)

Adjust the presser foot pressure according to the materials. (The standard height of pressure adjustment screw ① is 25mm).

1. Turn the screw ① clockwise (A direction) to increase the pressure, contrary, turn the screw ① counter-clockwise (B direction) to decrease the pressure.
2. After the proper pressure is got, tighten the nut ②.

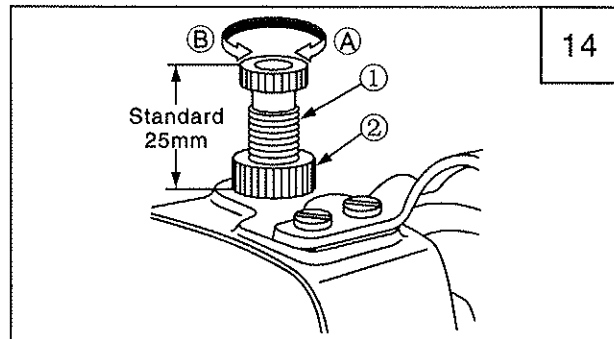

17.Adjusting the height of presser foot (Fig.15)

1. The optimum assembling position of presser foot is to adjust the presser foot to the "1/8" indication line on the feed crank.

Loosen the nut ① and adjust the cam link assembling position.

- a. At the highest position A, the max. presser foot vertical stroke is got;
 - b. At the lowest position B, the min. presser foot vertical stroke is got.
2. Usually, the stroke of outer presser foot and inner presser foot is equal.
 - a. Loosen the screw ②;
 - b. When the thread take-up lever is at its highest position, lay down the presser bar lever;
 - c. Adjust the feed crank ③ to leftward (A direction) to increase the presser foot stroke, contrary, adjust the feed crank ③ to rightward (B direction) to decrease the presser foot stroke.

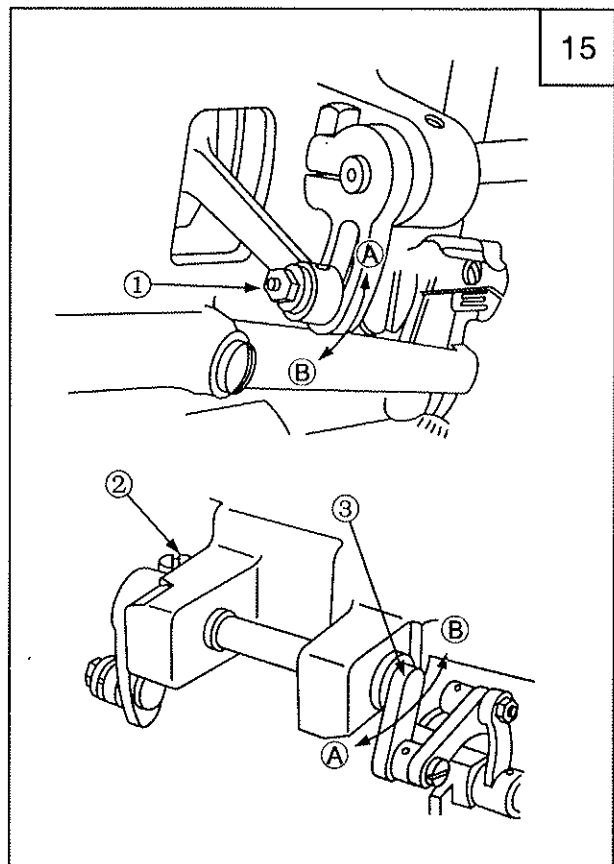

18. Adjusting the height of feed dog (Fig.16)

The standard position of feed dog is 1mm higher than the surface of throat plate.

Please adjust it as following order according to sewing requirement or after change a new feed dog:

1. Please confirm the highest position of feed dog;
2. Loosen the screw ③;
3. The height can be temporarily adjusted under the special condition;
4. After the required height is got, tighten the screw ③.

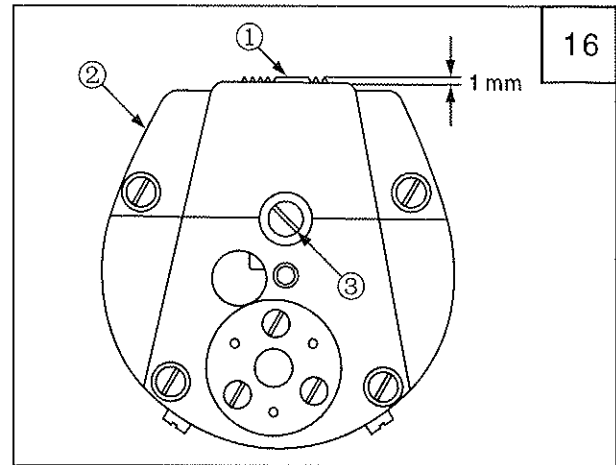

19. Adjusting the needle and hook (Fig.17)

1. Adjust the stitch dial to figure "3";
2. Turn the hand wheel to lower the needle bar to its lowest position, and loosen the screw ①;
3. Confirm the standard height of needle bar: Lift the needle bar up to 2.4mm from its lowest position, there should be 1.7mm clearance between upside of needle hole and the tip of hook guide ⑥; the lowest position of needle bar is that there is a clearance of 55.2mm from the bottom of needle bar rocking frame to the bottom of needle bar.
4. Loosen the screw ③, move the gear cover ②, and loosen the screw ④ and screw ⑧;
5. Loosen the screw ⑤, move the hook shaft saddle leftward or rightward, assure the clearance between the tip of hook guide and needle ⑦ is 0~0.05mm, after finish, tighten the screw;
6. Make the tip of hook guide align with the center of needle bar, then tighten the screw ④;
7. Turn the hand wheel clockwise, tighten the screws ⑧ alternately.

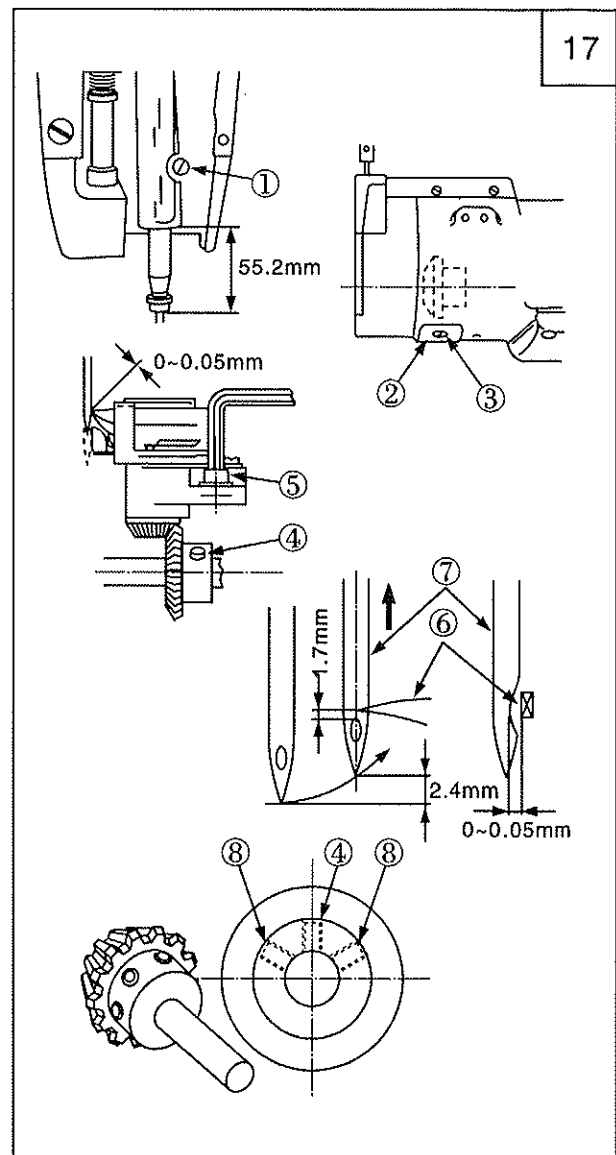

20. Adjusting the needle guard plate (Fig.18)

After changing hook, please confirm the position of needle guard plate. The standard position of needle guard plate is that needle guard plate ② is touched with the flank side of needle ① slightly, if not, bend the plate and adjust the position:

1. If the needle guard plate bends inward, please adjust the plate outward with a screwdriver;
2. If the needle guard plate bends outward, please adjust the plate inward with a screwdriver;

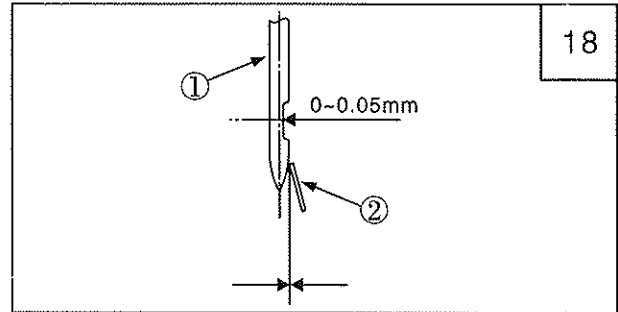

21. Adjusting the inner hook guide (Fig.19)

1. Turn the hand wheel to make the inner hook guide ① reach its final position;
2. Turn the bobbin case as the direction shown by arrow B until to the slit of throat plate ④;
3. Loosen the screw ⑤, then move the adjusting plate ⑥ of inner hook guide as arrow shown direction, assure the clearance between the inner hook guide and the bobbin cap flange is about 0.1~0.15mm.

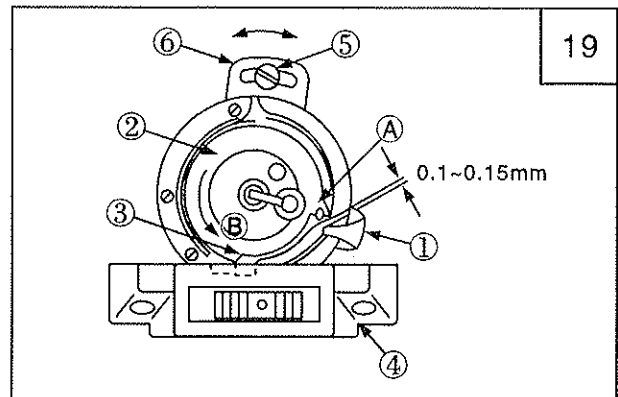

22. Adjusting the lengthways position of needle bar frame (Fig.20)

1. Adjusting the relationship between the inner presser foot bar and pressing bar:
 - a. Adjust the stitch dial to min. figure;
 - b. Loosen the screw ①, adjust the distance between the inner presser foot bar and pressing bar to 7.5mm.

Note: Don't make any clearance at axis direction of needle bar frame.

2. Adjusting the relationship between the feed dog and needle bar:
 - a. Adjust the stitch dial to min. figure;
 - b. Loosen the screw ③;
 - c. Adjust the position of feed dog to make the needle align with the center of needle hole on the throat plate (towards to the operator slightly).

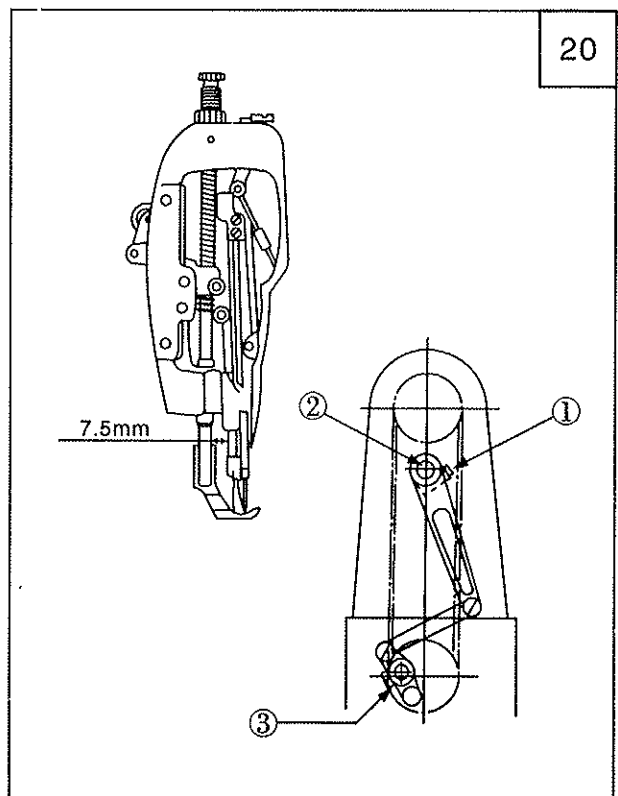

23. Safety clutch device(Fig.21)

If the hook blocks the thread when running, the safety clutch device will work, which make the lower timing pulley rotate without load.

1. Restore as following order:
 - a. Clean the thread blocked in the hook;
 - b. Press the button and turn the hand wheel at reverse direction.
2. Adjusting the force of safety clutch:

Turn the screw ② clockwise (A direction) to increase the force, contrary, turn the screw counter-clockwise (B direction) to decrease the force.

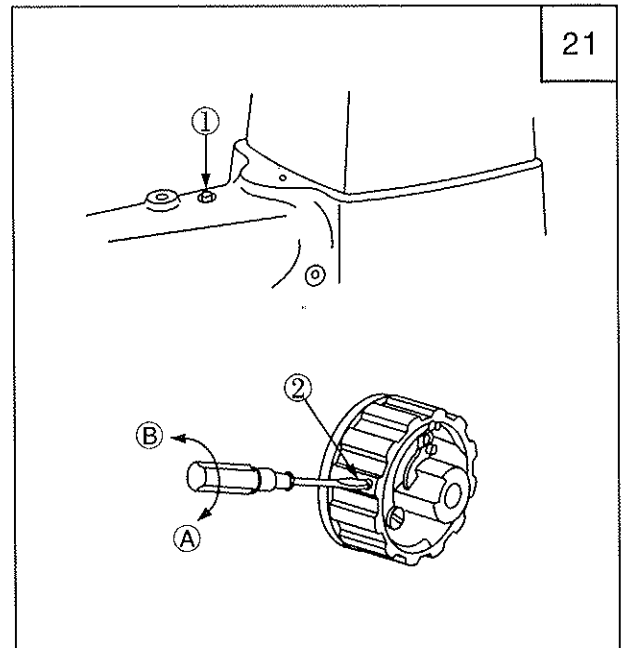

24. Reloading the timing belt (Fig.22)

1. Unloading the timing belt:
 - a. Loosen the screw ①, ②, ③, ④, ⑤;
 - b. Take the hand wheel ⑥ and bush ⑦ down;
 - c. Pull the feed lever ⑨ outward to make the timing belt ⑧ have enough space to pass through;
 - d. Take down the belt from the lower timing pulley, pull the belt and take it out from the bush hole of upper shaft.
2. Reloading the timing belt;
 - a. The loading order of timing belt is the reverse order of unloading;
 - b. Adjusting the timing relationship between upper shaft and lower shaft;

Turn the hand wheel to lift the thread take-up lever to its highest position, turn the lower shaft to make the first screw ⑪ on the collar ⑩ align with the mark ⑬ on the rear bush ⑫ of lower shaft, under this condition, install the belt on the lower timing pulley ⑭.

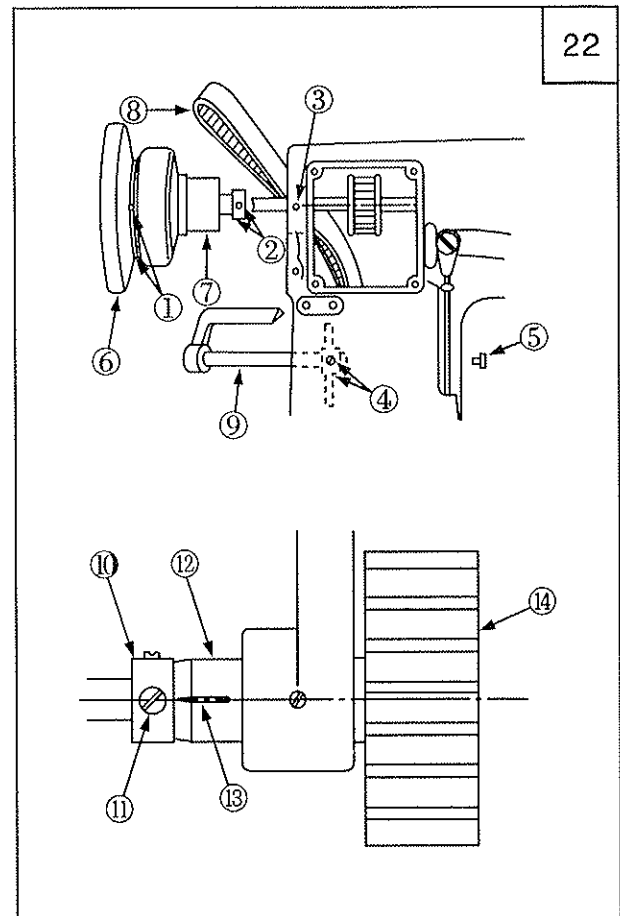

25. Trouble and remedy

Trouble	Causes	Remedy
<p>1. Thread breakage (thread wear and tear)</p>	<p>① Threading course, needle tip, hook guide tip or thread passing groove on the throat plate is rough. ② Too large needle thread tension. ③ Too big clearance of inner hook guide. ④ Collision between needle and hook guide tip. ⑤ Too small needle thread tension. ⑥ Too large or small thread take-up spring tension. ⑦ Not timing between needle and hook.</p>	<ul style="list-style-type: none"> ● Get rid of the burr on the hook guide tip and polish the thread passing groove on the throat plate with fine emery cloth. ● Adjust the needle thread to proper tension. ● Decrease the clearance, refer to 21. adjusting the inner hook guide. ● Refer to 19. adjusting the needle and hook. ● Adjust the needle thread to proper tension. ● Decrease the tension of thread take-up spring and increase the spring stroke. ● Refer to 19. adjusting the needle and hook.
<p>2. Skip stitch</p>	<p>① Too big clearance between needle and the tip of inner hook guide. ② Not timing between needle and hook ③ Too small pressure on the outer presser foot. ④ The height of needle bar is not enough. ⑤ No effect of needle guard plate. ⑥ Wrong needle size. ⑦ Wrong needle threading. ⑧ Rotary hook is scraped.</p>	<ul style="list-style-type: none"> ● Refer to 19. Adjusting the needle and hook. ● Refer to 19. Adjusting the needle and hook. ● Tighten the pressure screw. ● Refer to 19. Adjusting the needle and hook. ● Refer to 20. Adjusting the needle guard plate. ● Change a proper needle. ● Refer to 12. Threading the needle thread. ● Get rid of the burr on the hook guide tip with fine emery cloth.
<p>3. Loose stitch</p>	<p>① The thread passing parts are not smooth. ② The bobbin cannot rotate smoothly. ③ Too big clearance of inner hook guide. ④ Too weak tension of bobbin thread. ⑤ Too tighten when winding bobbin thread. ⑥ Bobbin thread doesn't pass the thread tension spring on the bobbin case</p>	<ul style="list-style-type: none"> ● Polish them with fine emery cloth. ● Reset the bobbin and rotary hook. ● Refer to 21. Adjusting the inner hook guide. ● Adjust the bobbin thread tension properly. ● Decrease the tension when winding. ● Threading the bobbin thread correctly.

PARTS LIST

1.Casting components

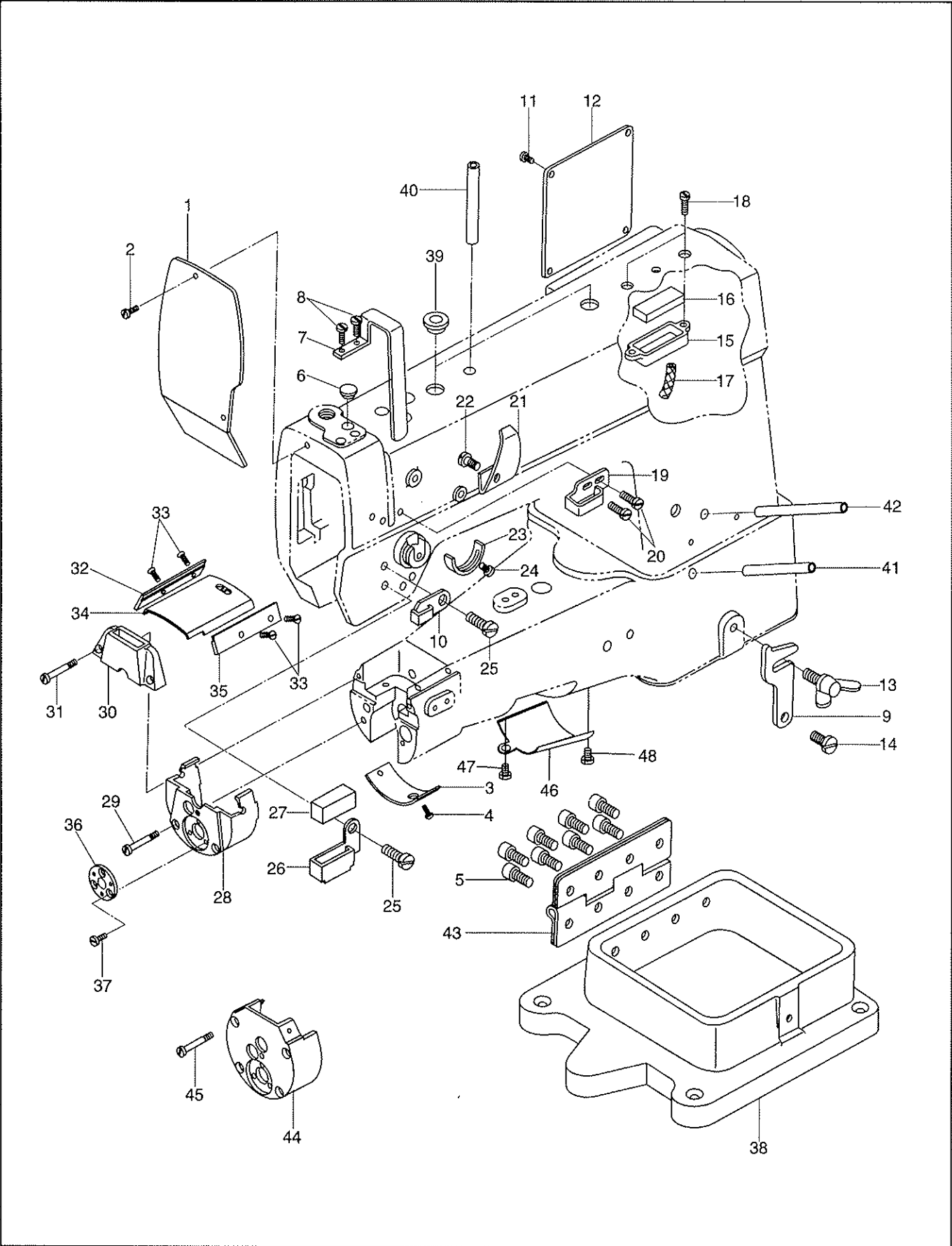

1. Casting components

Ref. NO.	Parts No.	Name of parts	Qty.	Remarks
1	50WF2-004	Face plate	1	
2	16WF1-059	Screw	2	SM9/64" × 40
3	50WF2-005	Gear cover	1	
4	13WF2-010	Screw	2	SM9/64" × 40
5		Screw	8	GB70-85 M8 × 20
6	50WF2-008	Rubber plug	1	
7	50WF2-009	Thread take-up lever cover	1	
8	1WF2-038	Screw	2	SM15/64" × 28
9	50WF2-010	Connecting hook	1	
10	16WF2-012	Thread guide(middle)	1	
11	7WF5-017	Screw	4	SM11/64" × 40
12	50WF2-013	Side plate	1	
13	50WF2-012	Wing bolt	1	
14	50WF2-011	Screw	1	
15	50WF2-019	Oil pan	1	
16	50WF2-020	Felt	1	
17		Oil wick	1	
18	7WF4-004	Screw	2	SM11/64" × 40
19	50WF2-014	Thread guide(upper)	1	
20	16WF2-015	Screw	2	SM9/64" × 40
21	50WF2-021	Take-up oil splasher	1	
22	19WF4-002	Screw	1	SM9/64" × 40
23	50WF2-022	Take-up spring adjusting plate	1	
24	1WF1-026	Screw	1	SM9/64" × 40
25	16WF2-015	Screw	2	SM9/64" × 40
26	50WF2-015	Thread guide(lower)	1	
27	50WF2-016	Felt	1	
28	50WF2-023	Throat plate base	1	
29	50WF2-024	Screw	2	SM11/64" × 40
30	50WF2-027	Throat plate	1	
31	50WF2-028	Screw	2	SM11/64" × 40
32	50WF2-029	Left side plate	1	
33	50WF2-031	Screw	4	SM9/64" × 40
34	50WF2-032	Bed slide	1	
35	50WF2-030	Right side plate	1	
36	50WF2-025	Lower shaft front cover	1	
37	50WF2-026	Screw	3	SM11/64" × 40
38	50WF2-003	Machine base	1	
39		Rubber plug	2	
40	50WF3-090	Oil tube	1	
41	50WF3-091	Oil tube	1	
42	50WF1-055	Oil tube	1	
43	50WF2-006	Hinge	1	
44		Throat plate base	1	1*
45		Screw	4	1* SM11/64" × 40
46	50WF2-007	Cylinder bed cover(lower)	1	
47	1WF1-016	Left screw	1	SM11/64" × 40
48	22WF5-027	Right screw	1	SM11/64" × 40

Note: #1 --- option

2.Upper shaft and thread take-up lever components

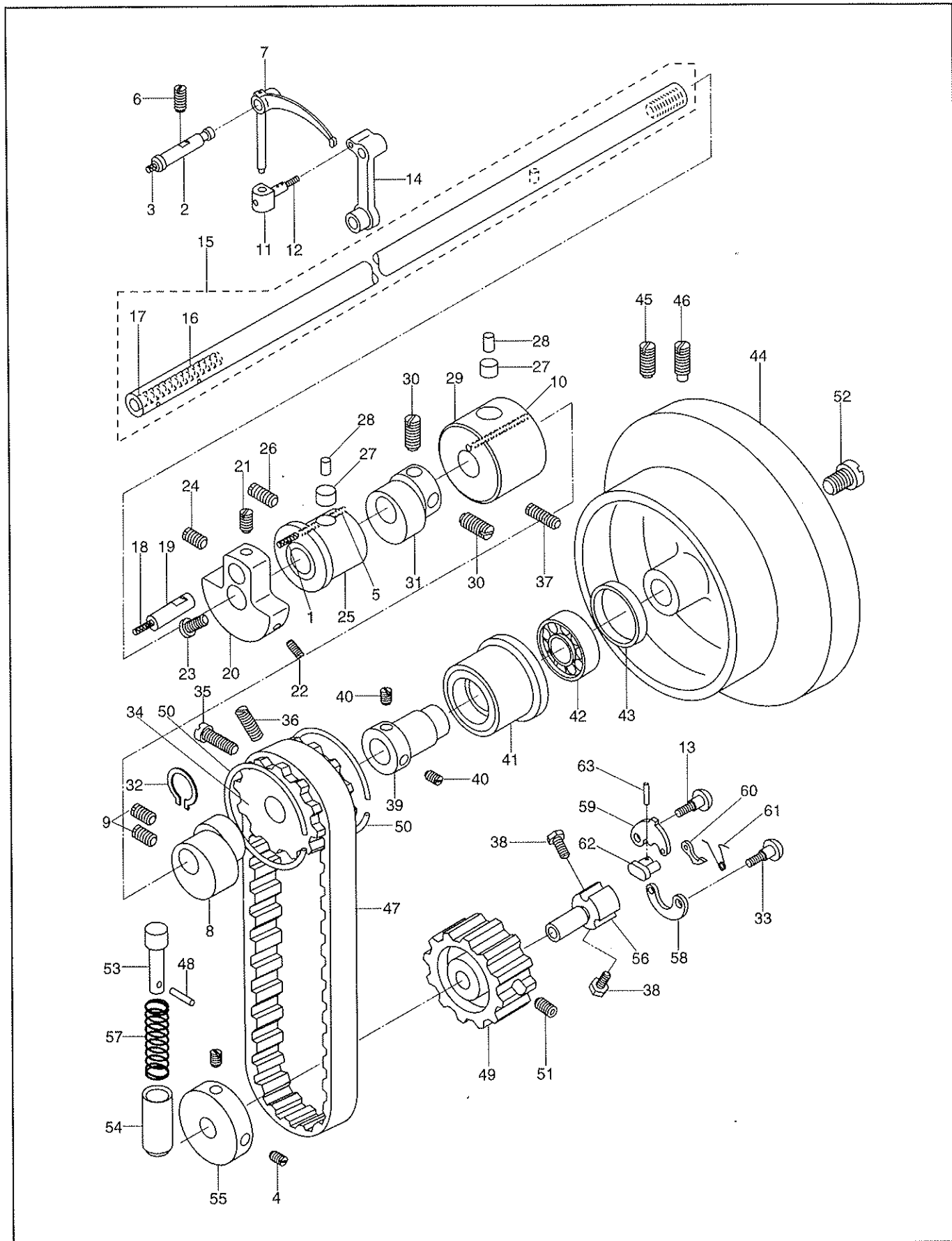

2.Upper shaft and thread take-up lever components

Ref. NO.	Parts No.	Name of parts	Qty.	Remarks
1		Plug	2	
2	16WF1-010	Take-up lever pin	1	
3		Oil wick	1	
4	50WF1-022	Screw	2	SM15/64" × 28
5		Oil wick	1	
6	50WF1-004	Screw	1	SM15/64" × 28
7	50WF1-005	Thread take-up lever	1	
8	50WF3-043	Feed cam	1	
9	18227	Screw	2	SM1/4" × 40
10		Oil wick	1	
11	50WF1-006	Take-up lever sliding block	1	
12		Oil wick	1	
13	50WF1-062	Hinge screw	1	
14	50WF1-007	Needle bar crank rod	1	
15	50WF1-015	Upper shaft	1	
16		Oil wick	1	
17	50WF1-014	Plug	1	
18		Oil wick	1	
19	50WF1-008	Crank pin	1	
20	50WF1-011	Needle bar crank	1	
21	50WF1-009	Screw	1	SM9/32" × 28
22	50WF1-013	Screw	1	SM9/32" × 28
23	50WF1-012	Screw	1	SM9/32" × 28
24	50WF1-010	Screw	1	SM9/32" × 28
25	50WF1-016	Upper shaft bush(front)	1	
26	50WF1-019	Screw	1	SM15/64" × 28
27	50WF1-017	Oil felt	2	
28		Oil felt	2	
29	50WF1-018	Upper shaft bush(middle)	1	
30	18227	Screw	2	SM1/4" × 40
31	50WF3-034	Upper feed driving cam	1	
32		Retaining ring	1	GB894.2-86 26
33	50WF1-062	Screw	1	
34	50WF1-024	Timing pulley(upper)	1	
35	50WF1-025	Set screw	1	
36	50WF1-013	Screw	1	
37	50WF1-019	Screw	1	
38	50WF1-035	Screw	2	
39	50WF1-021	Upper shaft bearing bush	1	
40	50WF1-022	Screw	2	
41	50WF1-020	Upper shaft bush(rear)	1	
42		Bearing	1	15 × 35 × 11 (202 type)
43	50WF1-023	Retaining collar	1	
44	50WF1-028	Hand wheel	1	
45	50WF1-019	Screw	1	SM15/64" × 28
46	50WF1-029	Screw	1	SM15/64" × 28
47	50WF1-027	Timing belt	1	
48		Spring pin	1	GB879-86 2 × 10
49	50WF1-032	Timing pulley(lower)	1	
50	16WF1-043	Spring ring	2	
51	21WF6-007	Screw	2	SM9/64" × 40
52	50WF1-030	Screw	1	SM5/16" × 24
53	50WF1-051	Safety clutch push button	1	
54	50WF1-053	Push button cylinder	1	
55	50WF1-052	Safety clutch disc	1	
56	50WF1-034	Safety base	1	
57	16WF3-046	Spring	1	
58	22WF1-013	Safety clutch spring	1	
59	22WF1-018	Safety clutch hook	1	
60	22WF1-016	Safety clutch counter-hook	1	
61	22WF1-014	Counter-hook spring	1	
62	22WF1-017	Safety clutch link	1	
63		Safety clutch link pin	1	

3. Needle bar and hook driving shaft components

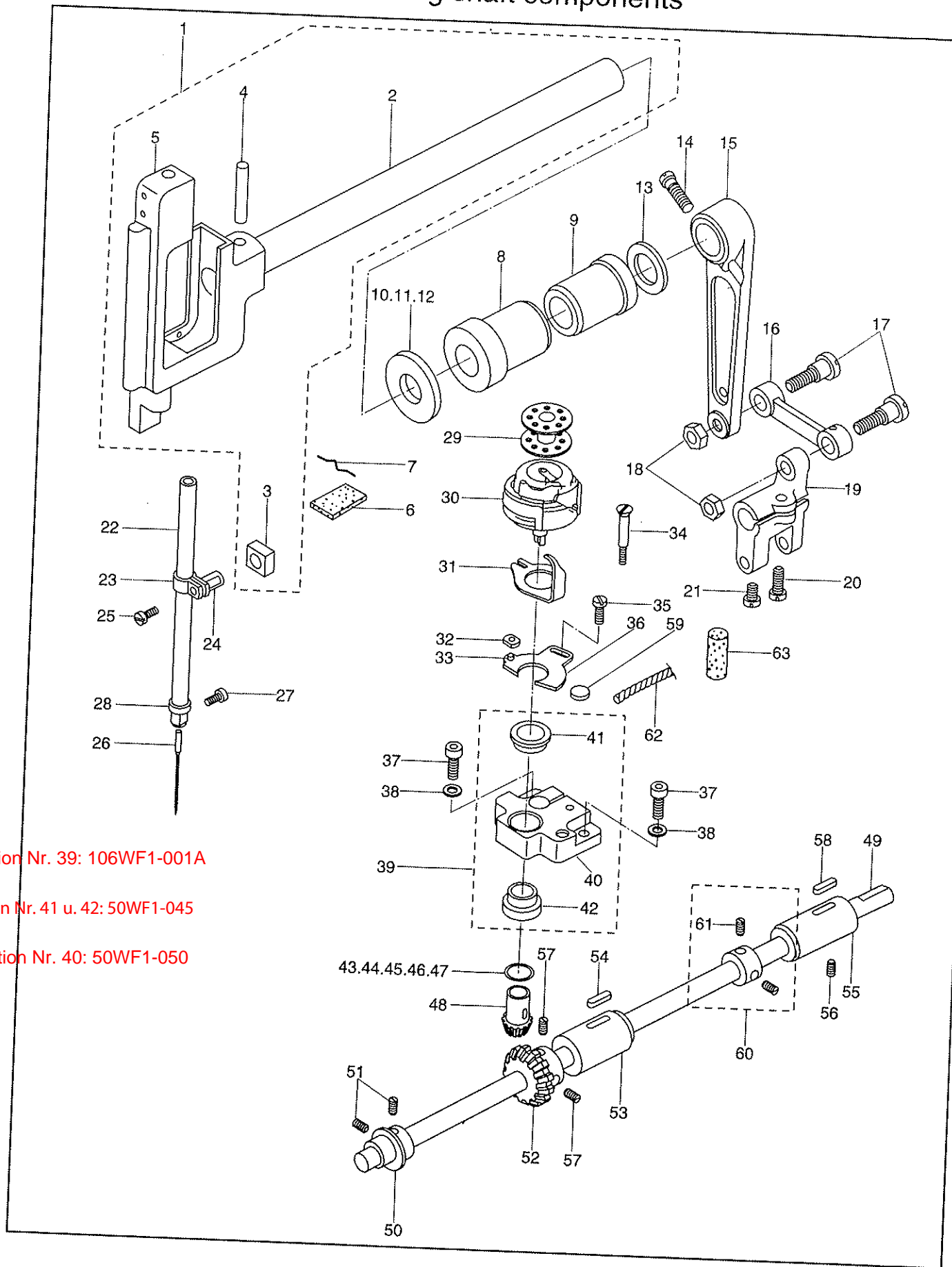

Position Nr. 39: 106WF1-001A

Positin Nr. 41 u. 42: 50WF1-045

Position Nr. 40: 50WF1-050

3. Needle bar and hook driving shaft components

Ref. NO.	Parts No.	Name of parts	Qty.	Remarks
1		Needle bar rocking frame assembly	1	
2	50WF3-001	Needle bar rocking frame shaft	1	
3	50WF3-002	Needle bar slide block	1	
4		Pin	1	GB117-86 A5 × 28
5	50WF3-003	Needle bar rocking frame	1	
6	50WF3-004	Felt	1	
7	50WF3-005	Retainer	1	
8	50WF3-006	Rocking shaft bush(front)	1	
9	50WF3-007	Rocking shaft bush(rear)	1	
10	50WF3-008	Washer	1	T=1.5
11		Washer	1	T=1.35 1"
12		Washer	1	T=1.65 1"
13		Washer	1	T=1.65
14	50WF3-010	Screw	1	SM15/64" × 28
15	50WF3-009	Rocking shaft crank	1	
16	50WF3-011	Connecting rod	1	
17	50WF3-012	Hinge screw	2	
18	50WF3-013	Nut	2	SM9/32" × 28
19	50WF3-014	Feed shaft crank	1	
20	34T5-540	Screw	1	SM15/64" × 28
21	36T5-008E5	Screw	1	SM11/64" × 40
22	50WF1-001	Needle bar	1	
23	50WF1-003	Needle bar connection	1	
24		Felt	1	
25	22TW3-014	Screw	1	SM9/64" × 40
26		Needle	1	DP × 17
27	22T2-017	Screw	1	SM1/8" × 40
28	50WF1-002	Needle bar thread guide	1	
29	33T1-027	Bobbin	1	
30		Rotary hook	1	SKRT341-NR
31	50WF1-047	Inner hook guide	1	
32	50WF1-048	Slide block	1	
33		Slide block pin	1	
34	50WF1-046	Screw	1	
35	16WF2-017	Screw	1	SM9/64" × 40
36	50WF1-049	Adjusting plate	1	
37		Screw	2	GB70-85 M5 × 12
38		Washer	2	GB95-85 5
39		Hook shaft saddle assembly	1	
40	50WF1-050	Hook shaft saddle	1	
41		Hook shaft bush(upper)	1	
42	50WF1-045	Hook shaft bush(lower)	1	
43		Washer	1	T=1.88 1"
44		Washer	1	T=1.92 1"
45	50WF1-044	Washer	1	T=1.96
46		Washer	1	T=2.00 1"
47		Washer	1	T=2.04 1"
48	50WF1-043	Hook shaft gear	1	
49	50WF1-031	Lower shaft	1	
50	50WF3-016	Feed cam	1	
51	50WF3-017	Screw	2	SM15/64" × 28
52	50WF1-040	Lower shaft bevel gear	1	
53	50WF1-036	Lower shaft bush(front)	1	
54	50WF1-037	Oil felt	1	
55	50WF1-038	Lower shaft bush(rear)	1	
56	50WF1-022	Screw	1	SM15/64" × 28
57	50WF1-041	Screw	3	SM1/4" × 40
58	50WF1-039	Felt	1	
59		Felt	1	
60	50WF1-042	Lower shaft collar	1	
61	17027	Screw	2	SM11/64" × 40
62		Oil wick	1	
63		Felt	1	

Note: #1 ----option

4. Presser foot components

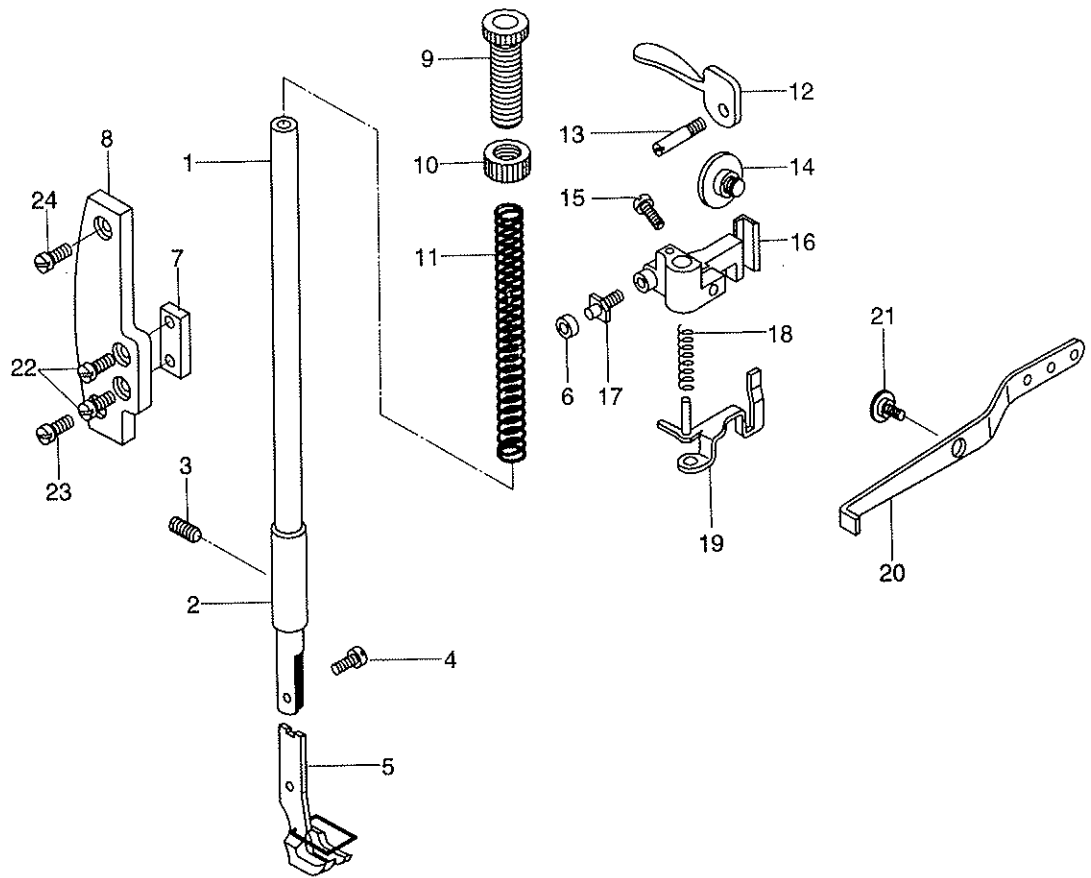

4.Presser foot components

Ref. NO.	Parts No.	Name of parts	Qty.	Remarks
1	22WF3-005	Presser bar	1	
2	50WF4-001	Presser bar lower bush	1	
3	50WF1-022	Screw	1	SM15/64" × 28
4	22WF3-014	Screw	1	SM9/64" × 40
5	50WF4-002	Outer presser foot assembly	1	
6	50WF4-011	Connecting pin roller	1	
7	50WF4-017	Presser bar bracket guide	1	
8	50WF4-015	Guide plate base	1	
9	1KT4-001	Pressure adjustment screw	1	
10	1KT4-002	Nut	1	
11	50WF4-006	Presser spring	1	
12	50WF4-007	Hand lifter	1	
13	50WF4-008	Hand lifter pin	1	
14	50WF4-014	Hinge screw	1	
15	16034	Screw	1	SM11/64" × 40
16	50WF4-009	Presser lifting lever base	1	
17	50WF4-010	Screw	1	
18	50WF4-013	Spring	1	
19	50WF4-012	Thread release guide assembly	1	
20	50WF4-018	Presser bar lifting lever	1	
21	50WF4-019	Hinge screw	1	
22	22WF2-017	Screw	2	SM3/16" × 32
23	50WF4-016	Screw	1	SM15/64" × 28
24	22WF2-017	Screw	1	SM3/16" × 32

5.Upper feed mechanism components

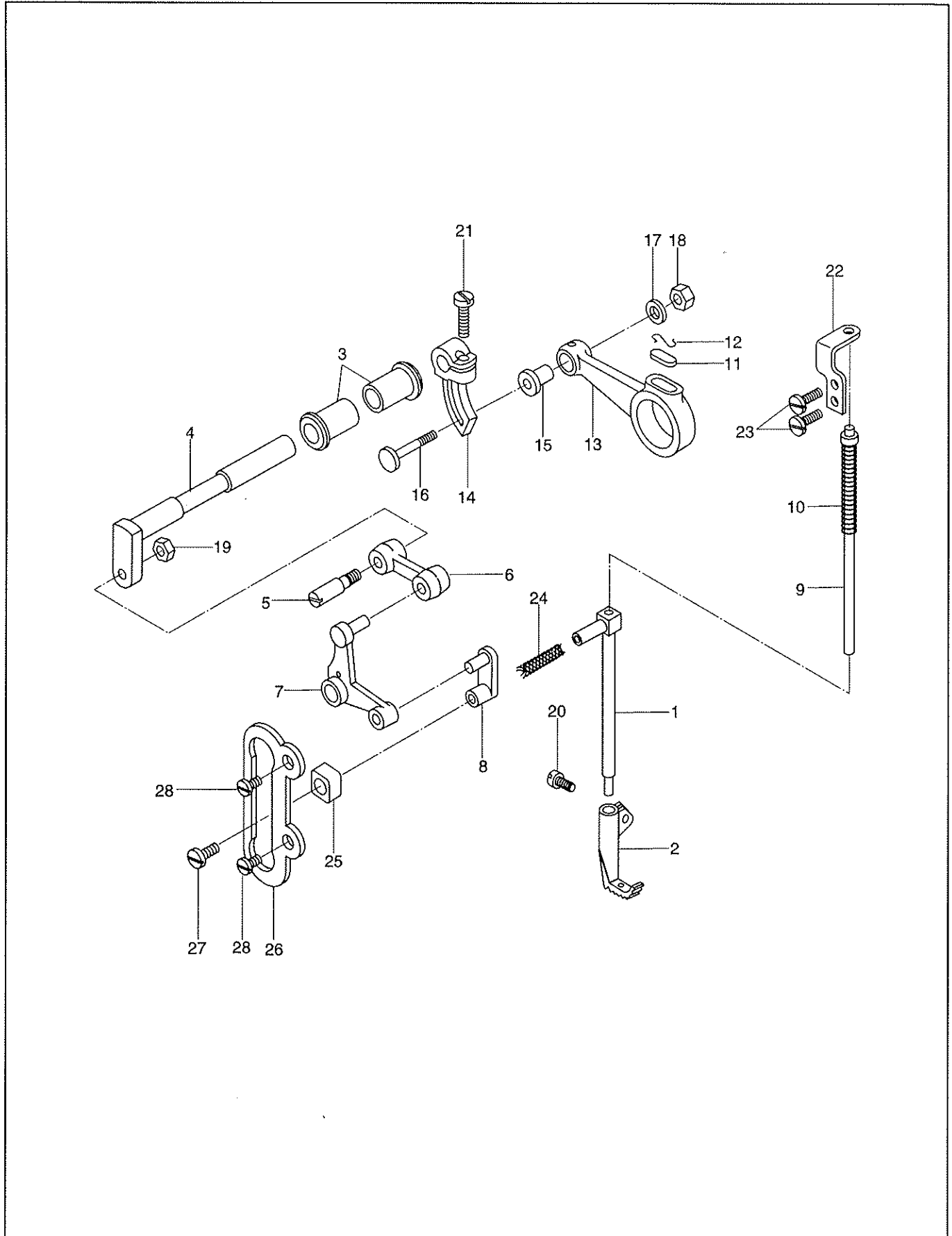

5.Upper feed mechanism components

Ref. NO.	Parts No.	Name of parts	Qty.	Remarks
1	55WF3-018	Inner presser foot bar	1	
2	50WF3-019	Inner presser foot	1	
3	50WF3-021	Bush	2	
4	50WF3-022	Upper feed shaft	1	
5	50WF3-023	Screw stud	1	
6	50WF3-025	Upper feed connecting link	1	
7	50WF3-026	Upper feed sewing plate	1	
8	50WF3-027	Inner presser foot driving link	1	
9	50WF3-031	Inner presser foot rod	1	
10	50WF3-032	Inner presser foot spring	1	
11	50WF3-036	Felt	1	
12	22WF4-040	Felt retainer	1	
13	50WF3-035	Upper feed driving rod	1	
14	50WF3-038	Upper feed crank	1	
15	50WF3-037	Connecting stud	1	
16	50WF3-040	Hinge screw	1	
17	50WF3-041	Washer	1	
18	50WF3-042	Nut	1	SM11/64" × 40
19	50WF3-024	Nut	1	SM1/4" × 40
20	50WF3-020	Screw	1	SM11/64" × 40
21	50WF3-039	Screw	1	SM1/4" × 24
22	50WF3-033	Inner presser foot retaining plate	1	
23	16WF1-059	Screw	2	SM9/64" × 40
24		Oil wick	2	
25	50WF3-029	Slide block	1	
26	50WF3-030	Slider block holder	1	
27	17078	Screw	1	SM11/64" × 40
28	1WF1-011	Screw	2	SM11/64" × 40

6. Lower feed mechanism components

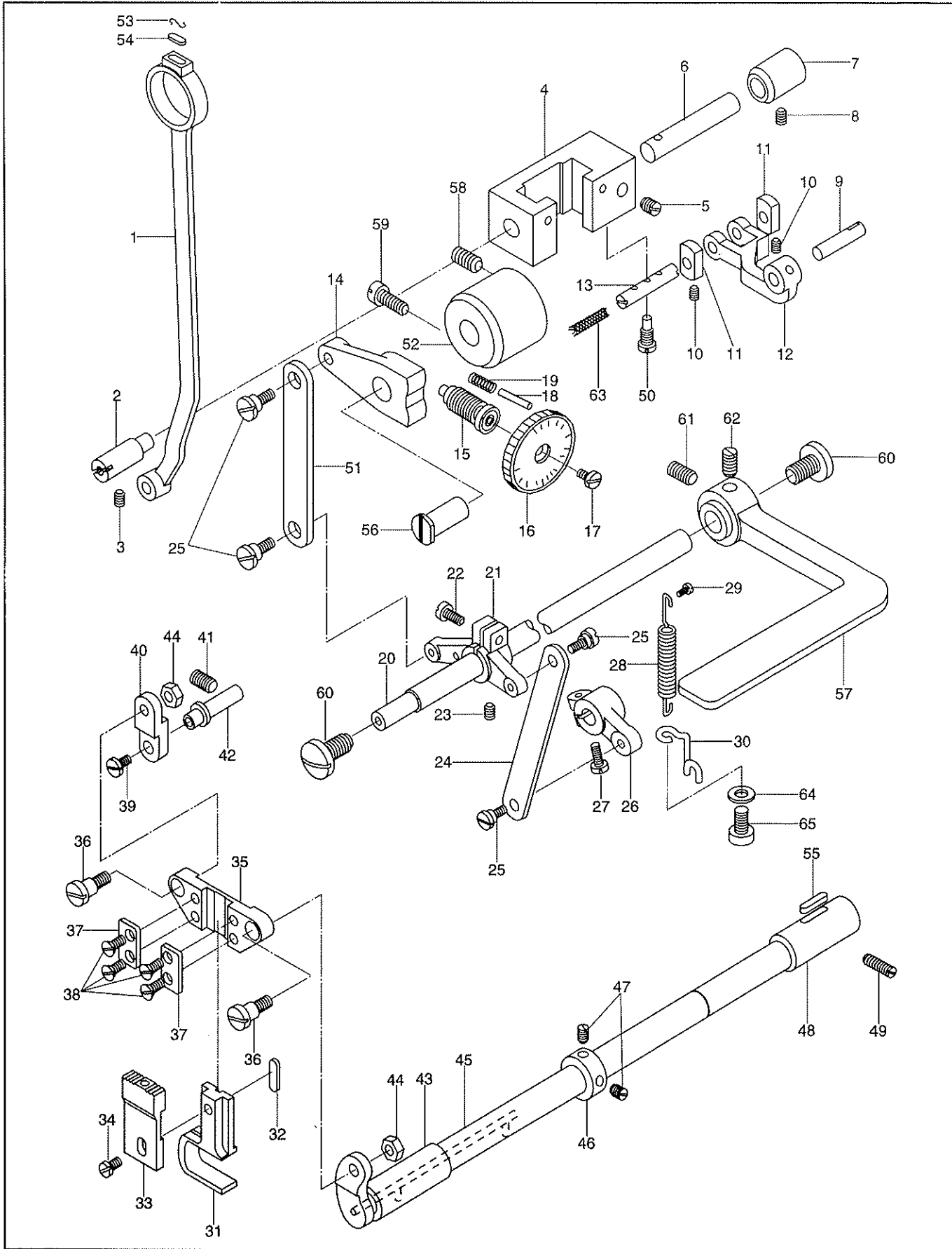

6.Lower feed mechanism components

Ref. NO.	Parts No.	Name of parts	Qty.	Remarks
1	50WF3-044	Feed connecting rod	1	
2	50WF3-045	Hinge pin	1	
3	50WF3-017	Screw	1	SM11/64" × 28
4	50WF3-046	Reverse feed driving rocker	1	
5	J0.0.40	Screw	1	
6	50WF3-047	Reverse feed driving rocker shaft	1	
7	50WF3-049	Bush	1	
8	50WF3-017	Screw	1	SM15/64" × 28
9	50WF3-015	Pin	1	
10	50WF3-051	Screw	2	SM9/64" × 40
11	50WF3-050	Slide block	2	
12	50WF3-053	Link	1	
13	50WF3-052	Slide block shaft	1	
14	50WF3-059	Feed regulator	1	
15	50WF3-056	Screw	1	
16	50WF3-055	Stitch dial	1	
17	50WF3-057	Screw	1	SM3/16" × 28
18	17WF4-035	Pin	1	
19	50WF3-058	Spring	1	
20	50WF3-062	Reverse feed lever shaft	1	
21	50WF3-066	Reverse feed lever shaft crank	1	
22	16056	Screw	1	
23	50WF3-017	Screw	1	SM3/16" × 28
24	50WF3-068	Reverse feed crank link	1	SM15/64" × 28
25	50WF3-069	Hinge screw	4	
26	50WF3-074	Crank	1	
27	16056	Screw	1	SM3/64" × 28
28	50WF3-070	Tension spring	1	
29	50WF3-071	Screw	1	
30	50WF3-072	Suspension hook	1	
31	50WF3-084	Feed bar crank	1	
32	50WF3-085	Oil felt	1	
33	50WF3-086	Feed dog	1	
34	22WF4-014	Screw	1	
35	50WF3-080	Feed bar support	1	
36	50WF3-083	Hinge screw	2	
37	50WF3-081	Feed bar support plate	1	
38	50WF3-082	Screw	4	SM1/8" × 44
39	50WF3-089	Screw	1	SM11/64" × 40
40	50WF3-087	Feed bar link	1	
41	50WF1-022	Screw	1	SM15/64" × 28
42	50WF3-088	Pin	1	
43	50WF3-075	Feed shaft bush(front)	1	
44	50WF3-024	Nut	2	SM1/4" × 40
45	50WF3-078	Feed shaft	1	
46	50WF3-079	Feed shaft collar	1	
47	18227	Screw	2	SM1/4" × 40
48	50WF3-076	Feed shaft bush(rear)	1	
49	50WF1-019	Screw	1	SM15/64" × 28
50	50WF3-048	Screw	1	SM15/64" × 28
51	50WF3-067	Link	1	
52	50WF3-060	Feed regulator bush	1	
53	50WF4-040	Felt retainer	1	
54	50WF3-036	Oil felt	1	
55	50WF3-077	Oil felt	1	
56	50WF3-061	Hinge pin	1	
57	50WF3-064	Feed lever	1	
58	50WF1-022	Screw	1	SM15/64" × 28
59	1WF2-029	Screw	1	SM15/64" × 28
60	50WF3-063	Screw	2	SM3/16" × 32
61	1WF2-010	Screw	1	SM1/4" × 40
62	50WF3-065	Screw	1	SM1/4" × 40
63		Oil wick	1	
64	50WF3-073	Washer	1	
65	22WF3-014	Screw	1	SM9/64" × 40

7.Thread tension components

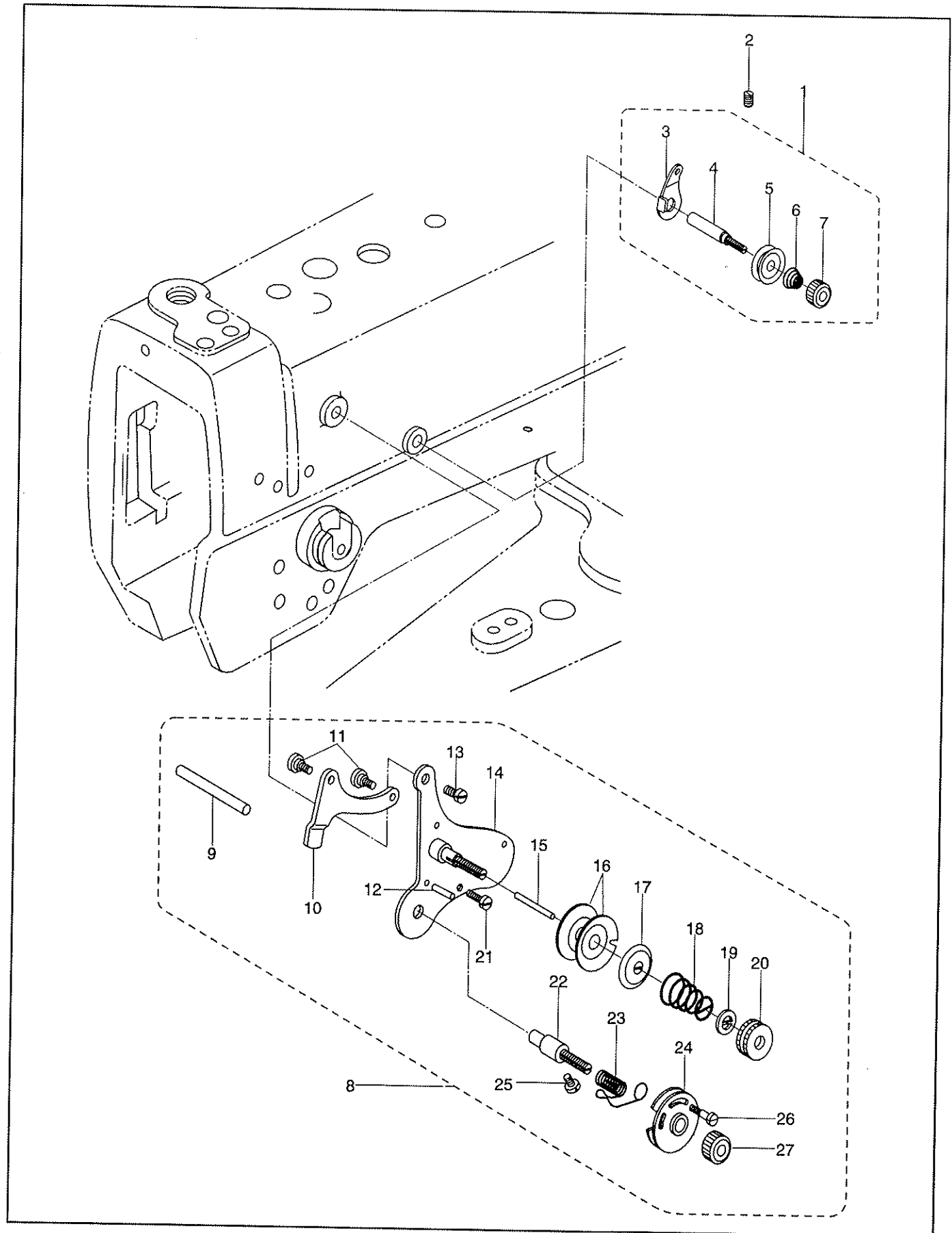

7.Thread tension components

Ref.NO.	Parts No.	Name of parts	Qty.	Remarks
1	50WF2-035	Thread tension controller assembly	1	
2	1WF5-022	Screw	1	SM11/64" × 40
3	50WF2-035A2	Thread guide	1	
4	50WF2-035A1	First tension post	1	
5	50WF2-035A4	Thread tension disc	2	
6	50WF2-035A3	Spring	1	
7	50WF2-035A5	Thread tension nut	1	
8		Thread tension controller assembly	1	
9	16WF2-047	Thread tension release bar	1	
10	16WF2-046A14	Thread tension release lever	1	
11	16WF2-046A15	Hinge screw	2	
12	16WF2-046A12	Thread tension stud	1	
13	16WF2-020	Screw	1	SM11/64" × 32
14	50WF2-033	Thread tension controller base	1	
15	16WF2-046A13	Thread release pin	1	
16	16WF2-046A6	Thread tension disc	2	
17	16WF2-046A5	Thread tension disc	1	
18	16WF2-046A4	Tension spring	1	
19	153029	Stopper	1	
20	16WF2-046A3	Thread tension stud nut	1	
21	16WF2-015	Screw	1	SM9/64" × 40
22	16WF2-046A10	Thread take-up spring shaft	1	
23	16WF2-046A7	Thread take-up spring	1	
24	16WF2-046A8	Thread tension guide disc	1	
25	16WF2-033	Screw	1	SM11/64" × 32
26	16WF2-046A9	Screw	1	SM1/8" × 44
27	16WF2-046A11	Nut	1	

8. Belt cover and bobbin winder components

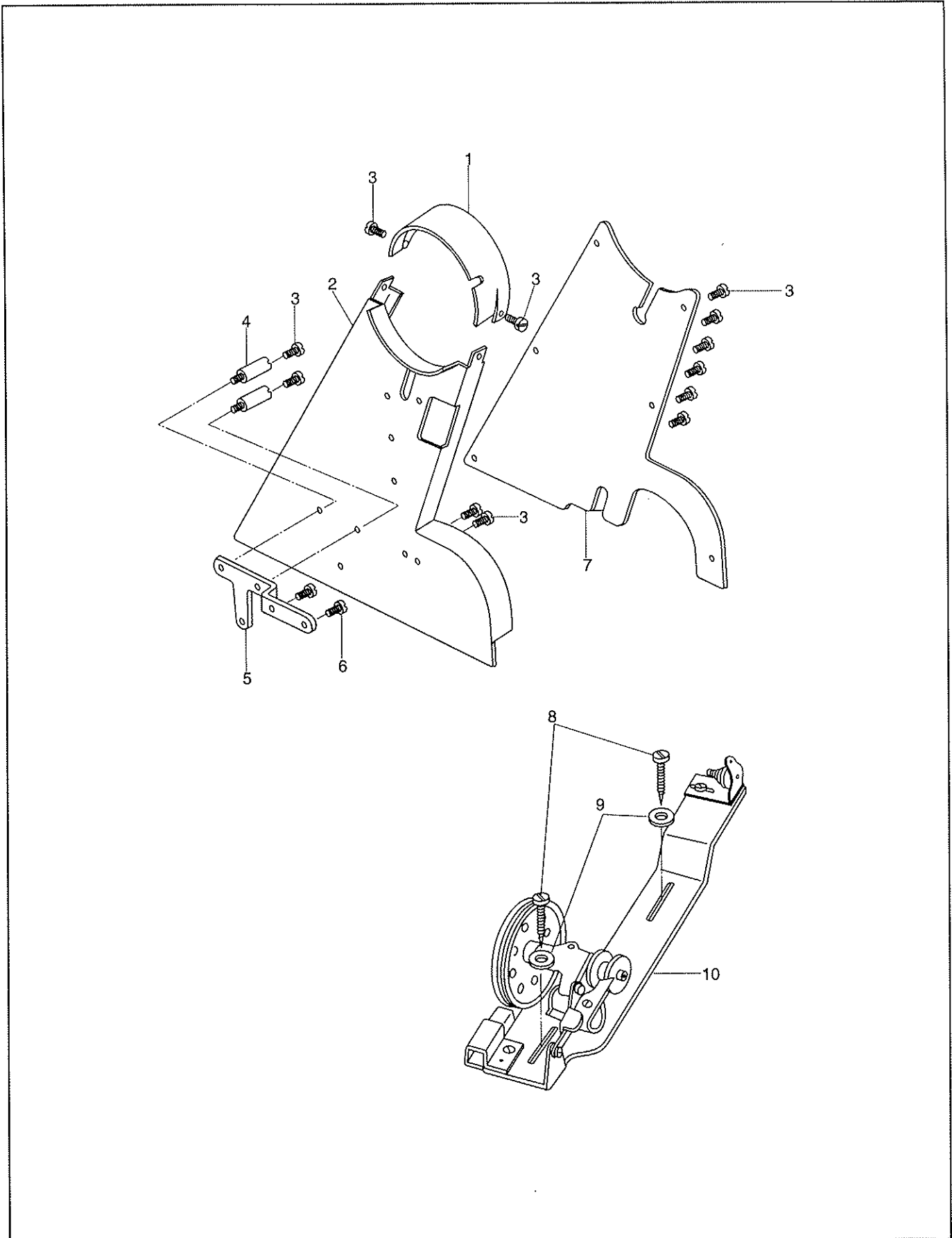

8. Belt cover and bobbin winder components

Ref. NO.	Parts No.	Name of parts	Qty.	Remarks
1	50WF5-007	Belt cover(3)	1	
2	50WF5-005	Belt cover(1)	1	
3	40T2-202	Screw	12	SM11/64" × 40
4	50WF5-009	Support screw	2	
5	50WF5-008	Belt cover support plate	1	
6	22T4-015	Screw	2	SM11/64" × 40
7	50WF5-006	Belt cover(2)	1	
8	33TF-017	Wooden screw	2	
9	33TF-011	Washer	2	
10	S14420020	Bobbin winder assembly	1	

9.Knee lifter components

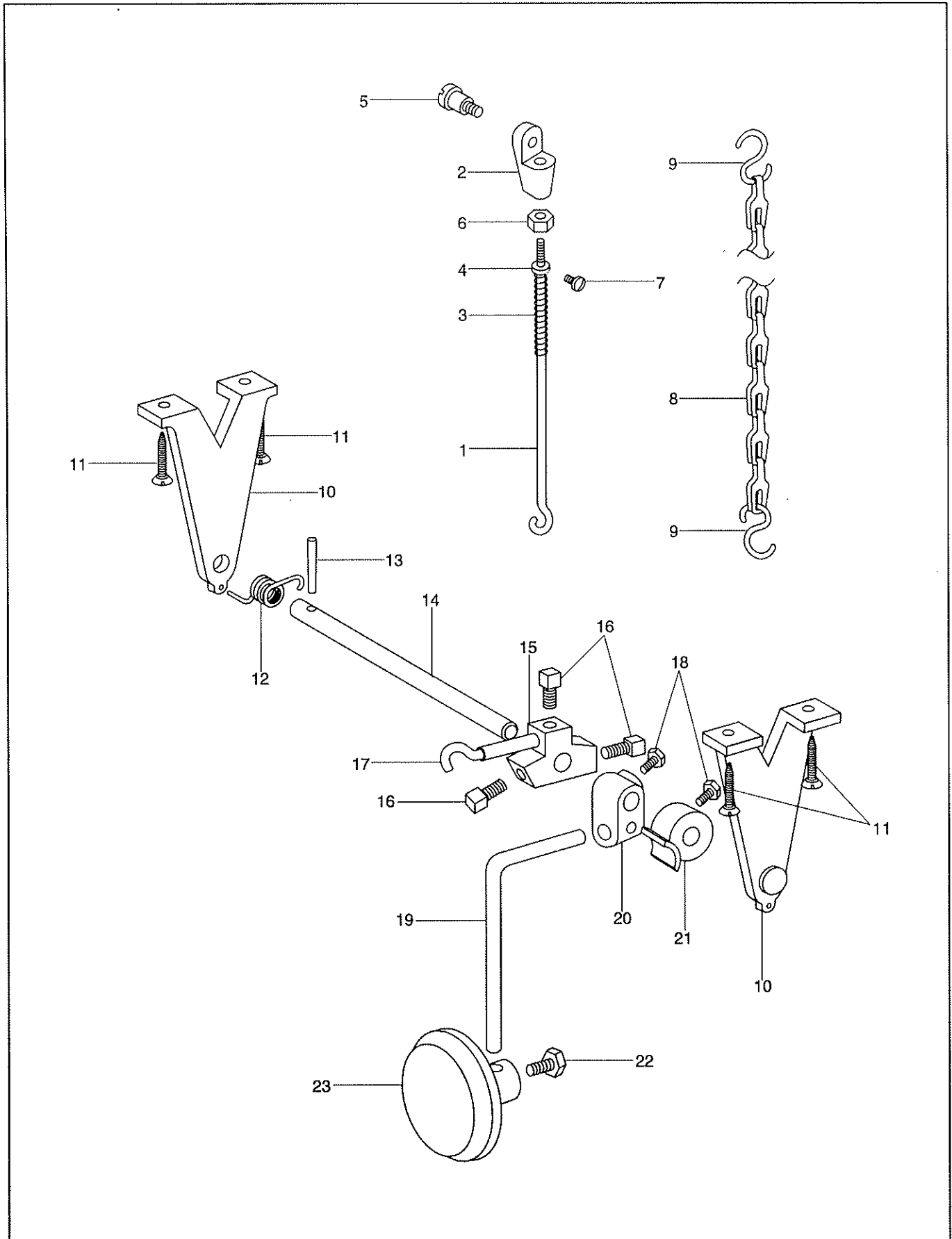

9.Knee lifter components

Ref. NO.	Parts No.	Name of parts	Qty.	Remarks
1	50WF4-020	Hanging rod	1	
2	50WF4-023	Bar connection	1	
3	50WF4-021	Spring	1	
4	50WF4-022	Spring holder	1	
5	50WF4-024	Hinge screw	1	
6	50WF2-018	Nut	1	
7	36T5-008E5	Screw	1	
8	606082	Chain	1	length 1000cm
9		"S" shaped hook	2	
10	33T5-005	Knee lifter base	2	
11		Wooden screw	4	GB99 ST5 × 8
12	33T5-006	Spring	1	
13		Pin	1	GB119 31 × 2
14	33T5-007B1	Knee lifter shaft	1	
15	50WF6-001	Knee lifter crank	1	
16		Set screw	3	GB821 M8 × 11
17	50WF6-002	Knee lifter crank hook	1	
18		Screw	2	GB821 M8 × 11
19	33T5-009	Knee lifter plate rod	1	
20	33T5-008	Bracket	1	
21	33T5-011E	Knee lifter adjustment bracket	1	
22		Hexagonal screw	1	GB21 M6 × 10
23	33T5-010F	Knee lifter press assembly	1	

10. Accessories

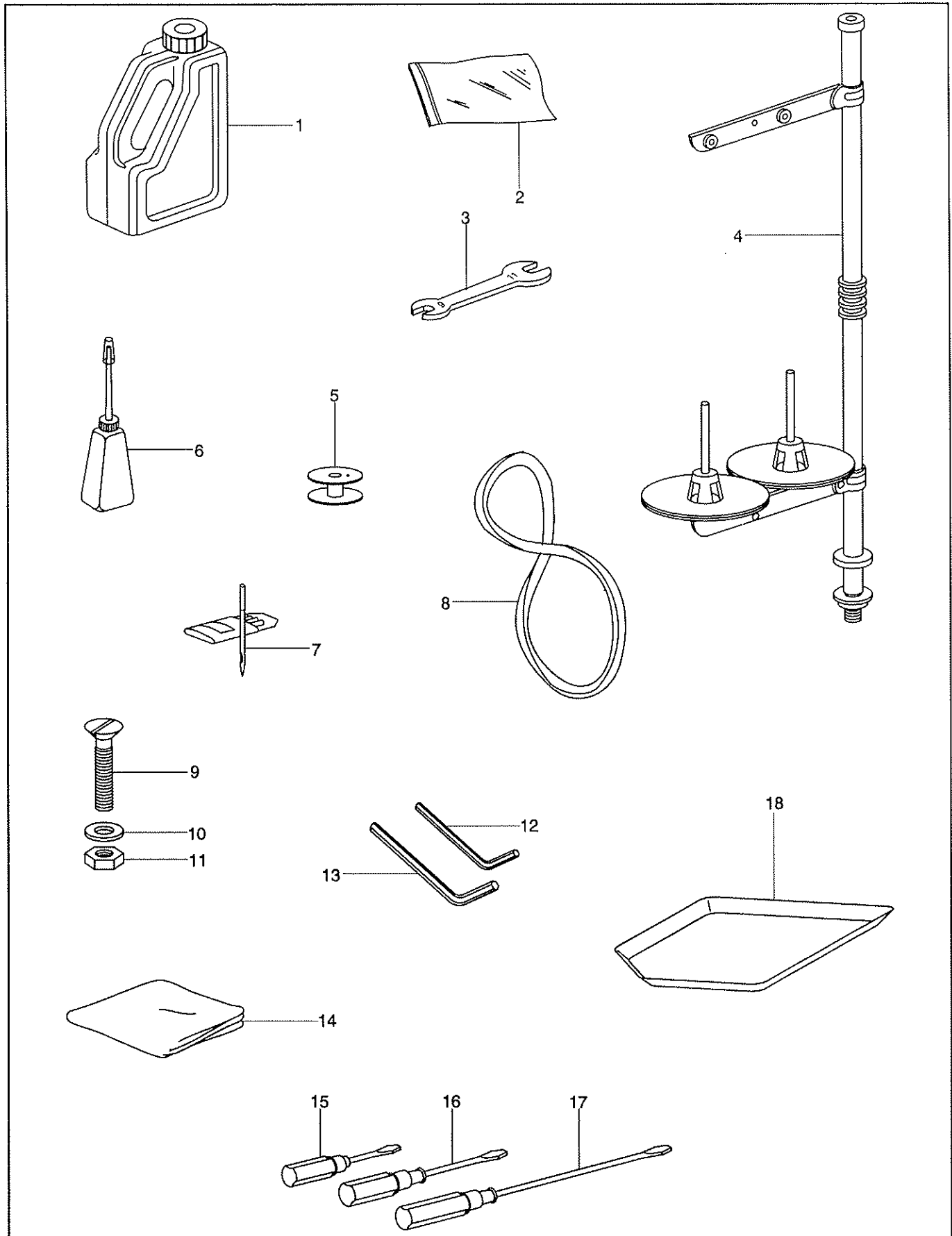

10. Accessories

Ref. NO.	Parts No.	Name of parts	Qty.	Remarks
1	1F-009	Oil box	1	
2	33TF-010	Parts bag	1	
3		Wrench	1	
4	4F-007	Thread stand assembly	1	
5	33T1-027	Bobbin	6	
6	33TF-011	Oil pot	1	
7		Needle	5	DP × 17
8		V-belt	1	
9	50WF5-010	Screw	4	M6 × 70
10		Washer	4	GB5287-856
11		Nut	4	GB41-85 M6
12		Hexagonal wrench 3	1	S=3
13		Hexagonal wrench 4	1	S=4
14	1F-013	Machine cover	1	
15	33TF-014	Screw driver (small)	1	
16	33TF-013	Screw driver (middle)	1	
17	33TF-012	Screw driver (big)	1	
18	50WF5-011	Oil pan	1	