

TYPICAL

GC6150M/H/B SERIES

HIGH SPEED LOCKSTITCH SEWING MACHINE



※NOTE

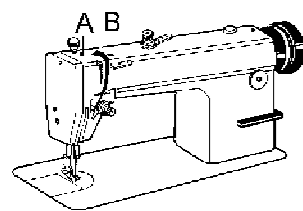

Before putting a new machine into operation, remove the plugs(A) on the top of the arm and replenish sufficient amount of oil, then lift the presser foot and run the machine at a low speed of 2000 spm to check oil distributing condition through oil check window. When lubricating is normal, keep the machine run in at this speed for 30 minutes, then increase the running speed gradually. After one month run-in operation, the machine can be run at the Max speed under normal working

1. OIL FILLING

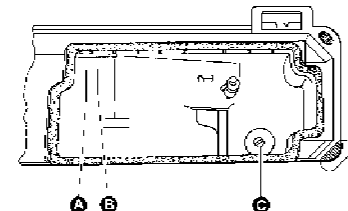

(1) The oil amount in the oil reservoir is controlled through the reference marks A and B shown in Fig2. The mark A indicates the max oil amount level, the mark B for the min. oil amount level. If the oil amount level is under the mark B replenish the oil reservoir with oil in time reservoir with oil in time.

(2) When filling oil, loosen the oil draining screw (c), drain off the remaining oil in the oil reservoir completely, clean the oil reservoir and tighten the oil draining screw(c), then fill the oil reservoir with fresh oil.

2. ROTATING HOOK OIL AMOUNT ADJUSTMENT

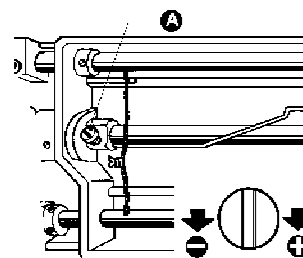

Adjust the oil amount of the rotating hook by turning the oil amount adjusting screw (A). Turn the screw(A) clockwise (in the "+" direction) to increase the oil amount; turn it counter-clockwise (in the "-" direction) to decrease the oil amount.

3. OIL PUMP ADJUSTMENT

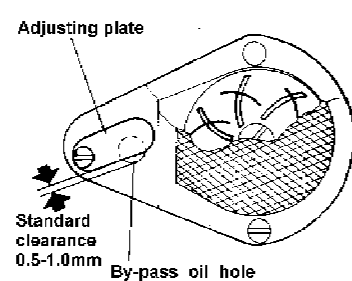

In ordinary operation, adjustment is not required for the oil pump. If oil splashing does not occur in the oil check window when the machine runs at a low speed, close the clearance of the bypass oil hole.

There isn't by-pass oil hole in GC6-9 series.

4. NEEDLE INSTALLATION

Turning the balance wheel to lift the needle bar to the upper end of its stroke. Loosen the needle clamp screw while keeping the long groove of the needle leftward, fully insert the needle shank up to the bottom of the needle socket, then tighten the needle clamp screw.

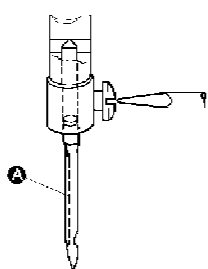

5. CONNECTION OF THE CLUTCH LEVER WITH THE PEDAL

(1) The optimum tilt angle of pedal is approximately 15 deg.
 (2) Adjust the clutch so that the clutch lever (c) align with the draw bar (B) as shown in Fig 6
 (3) The machine pulley should rotate counter clockwise when viewed from the outside of it. The rotating direction of motor pulley can be reversed by turning the plug of the motor at 180 deg.
 (4) Adjust the tension of O-Belt (F) by moving the motor up and down, the proper tension of the O-belt is a slack of 10-20 mm when the belt is depressed at the center of the belt by finger.

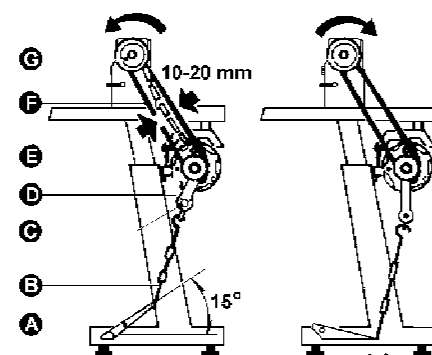

6. BELT COVER INSTALLATION

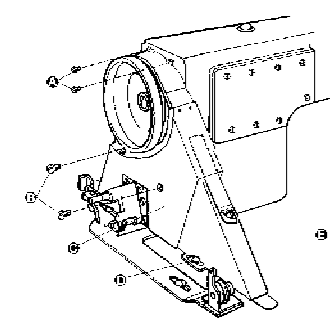

Install the belt cover for the sake of safety.
 Install belt cover(C) to arm with screw(A) and screw(B) and install belt cover(E) on board with screw(D).
 Note: there aren't screw(A) and screw holes on belt cover in GC6-9.

7. ADJUST THE OPENING TIME OF THE TENSION DISCS

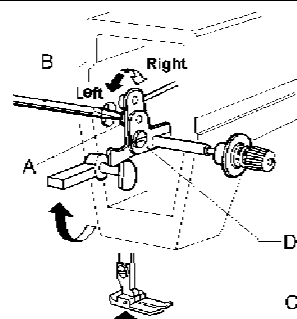

Within the presser foot lift range, the opening time of the tension discs can be adjusted as follows:
 (1) Remove the rubber plug from the back of the arm and Loosen the screw (A) of the knee lift lever (left)
 (2) Move the tension releasing cam (D) leftward for earlier opening or rightward for Later opening. It will facilitate the adjustment if putting a block under the presser foot lift.

8. THREADING

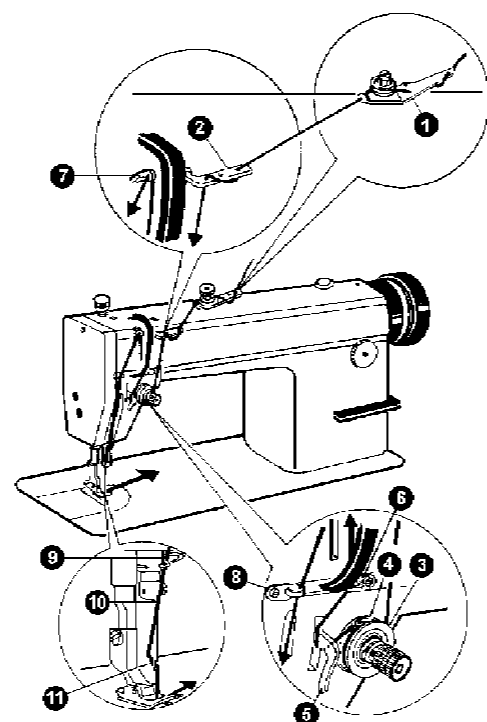

To thread the needle thread, raise the needle bar to the upper end of its stroke, lead the thread from the spool and perform threading as shown in Fig9. To draw the bobbin thread, hold the end of the needle thread and turn the balance wheel to lower the needle bar and then lift it to its highest position. Pull the ends of needle thread and bobbin thread forward under presser foot.

10. ADJUST THE PRESSURE OF PRESSER FOOT

Pressure of the presser foot is adjusted in accordance with thickness of materials to be sewn. First loosen the lock nut (A), for heavy materials, turn the pressure regulating thumb screw as shown in Fig 11 (a) to increase the pressure, while for light materials, turn the pressure regulating thumb screw as shown in Fig.11(b) to decrease the pressure, then tighten the lock nut (A).
 The pressure of the presser foot is recommended to be less as long as normal feeding is ensured.

9. WINDING INSTALLATION AND ADJUSTMENT

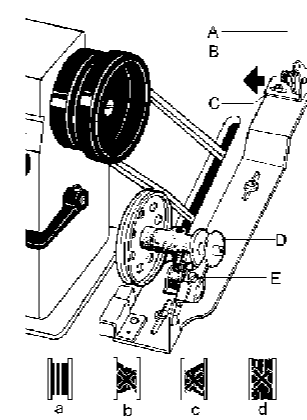

The bobbin winder pulley should Align with the V-belt and there should be some clearance between them. When the bobbin winder stop latch lever is depressed, the V-belt should be in touch with the bobbin winder buley in order that the bobbin winder pulley can be driven by the V-belt.

The thread wound on the bobbin should be neat and tight. If not tight, adjust the winding tension by turning the tension stud nut (A) of the bobbin winder tension bracket, when the thread wound on the bobbin does not present a cylindrical shape as shown in Fig.10 (a), Loosen the set screw(B) of the bobbin winder tension bracket and move the bracket (C) leftward or rightward, if the thread is wound as shown in the figure (b), move the bracket leftward or rightward of wound as shown in the figure(c), move it leftward. After positioning the bracket adequately, tighten the set screw (B).

Do not overfill the bobbin. The optimum wound length of the thread will fill about 80% of the bobbin capacity. This can be adjusted by the screw(E) of the bobbin winder stop latch.

11. THREAD TENSION ADJUSTMENT

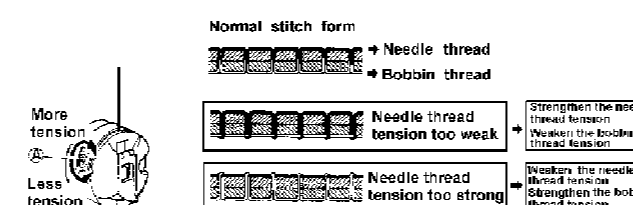

Thread tension should be determined in accordance with the stitch obtained by adjusting the tension of the bobbin thread and needle tension (Fig.12).
 The tension of the bobbin thread: to be adjusted by turning the tension spring regulating screw of the bobbin case. After adjusting, insert the bobbin into the bobbin case and hold the end of the thread from the bobbin case to hang the bobbin case, if the bobbin case falls slowly and evenly, the proper tension of the bobbin thread is obtained.
 The tension of needle thread: to be adjusted by turning the thumb nut.

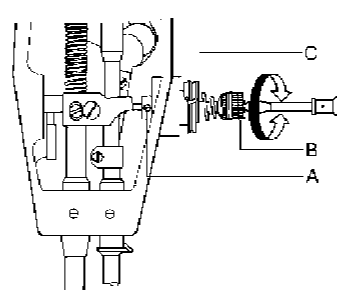

The stroke of the thread take-up spring runs from 6mm to 10mm, when sewing very thin fabrics, reduce the thread take-up spring tension and increase the thread take-up spring stroke, where as increase the thread take-up spring tension and reduce the thread take-up stroke when sewing very thick fabrics.
 Adjusting the thread take-up spring tension: (Fig.13) First loosen the set screw (A), Turn the tension stud (B) counter-clockwise to decrease the tension of the thread take-up spring (c) to zero, then turn the tension stud (B) clockwise till the spring (c) comes to the notch of the tension regulating bushing, and again turn the tension stud (B) halfway back (counter clockwise), After the adjustment, tighten the set screw (A).
 Adjusting the thread take-up spring stroke: (Fig.14) loosen the set screw (B) turn the stud (C) clockwise to increase the stroke or turn stud (C) counter-clockwise to decrease the stroke After the adjustment, tighten the set screw (B).

12. ADJUST THE SYNCHRONIZATION OF THE NEEDLE WITH ROTATING HOOK

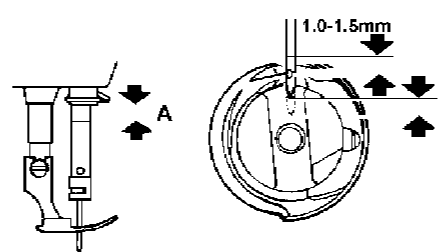

When lifting the needle bar from its lowest position of the stroke to the distance A, the hook point D of the bobbin should align with the center line of the needle and be 1.0-1.5 mm above upper end of the needle eye (Fig.15)

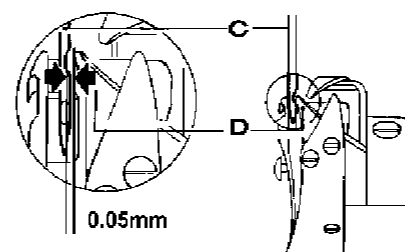

The clearance between the bottom of the needle notch and the hook point should be 0.05 mm.

	M	H	B
A	202	2	2.4

13. ADJUSTMENT OF STITCH LENGTH LENTH AND ADJUSTMENT

The stitch length can be adjusted by turning the dial (A). The figures on the face (B) of the dial show the stitch length in mm. the reverser feed lever must be depressed by another while adjusting the stitch length. The reverse feeding starts when the reverse feed lever (c) is depressed, the machine will feed forward again if the reverse feed lever is released.

NOTE: Push the press key "PUSH" to adjust the stitch length. It's designed to prevent knob from rotating at working in GC6-8 and GC6-9.

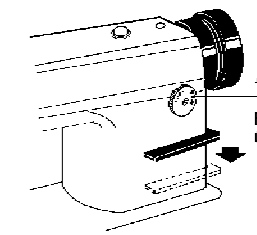

15. ADJUST THE SYNECHRONILATION OF THE NEEDLE MOTION WITH FEED MOTION

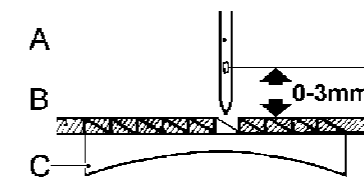

To adjust the feed dog position (C), first should release the two set screw (F) and turn around the balance wheel by hand. When the needle (A) point reaches the surface of the throat plate (B), the top of the feed dog (C) should be flush with the throat plate surface.

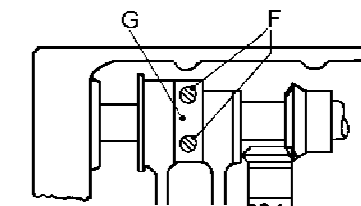

16. STITCHLENGTH ERROR ADJUSTMENT

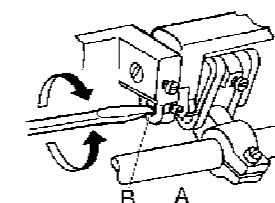

Loosen screw (A) to adjust the stitch length adjusting cam (B). Turn it rightward to narrow the stitch length as forward sewing, and widen it as reverse sewing; turn it leftward to widen the stitch length as forward sewing, and narrow it as reverse sewing.

17. FEED DOG HORI ONTALTY ADJUSTMENT

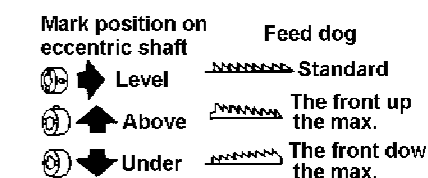

Heighten the front of feed dog to prevent fabric from wrinkling, lower the front of feed dog to prevent fabric from deflection, breaking of hook thread.

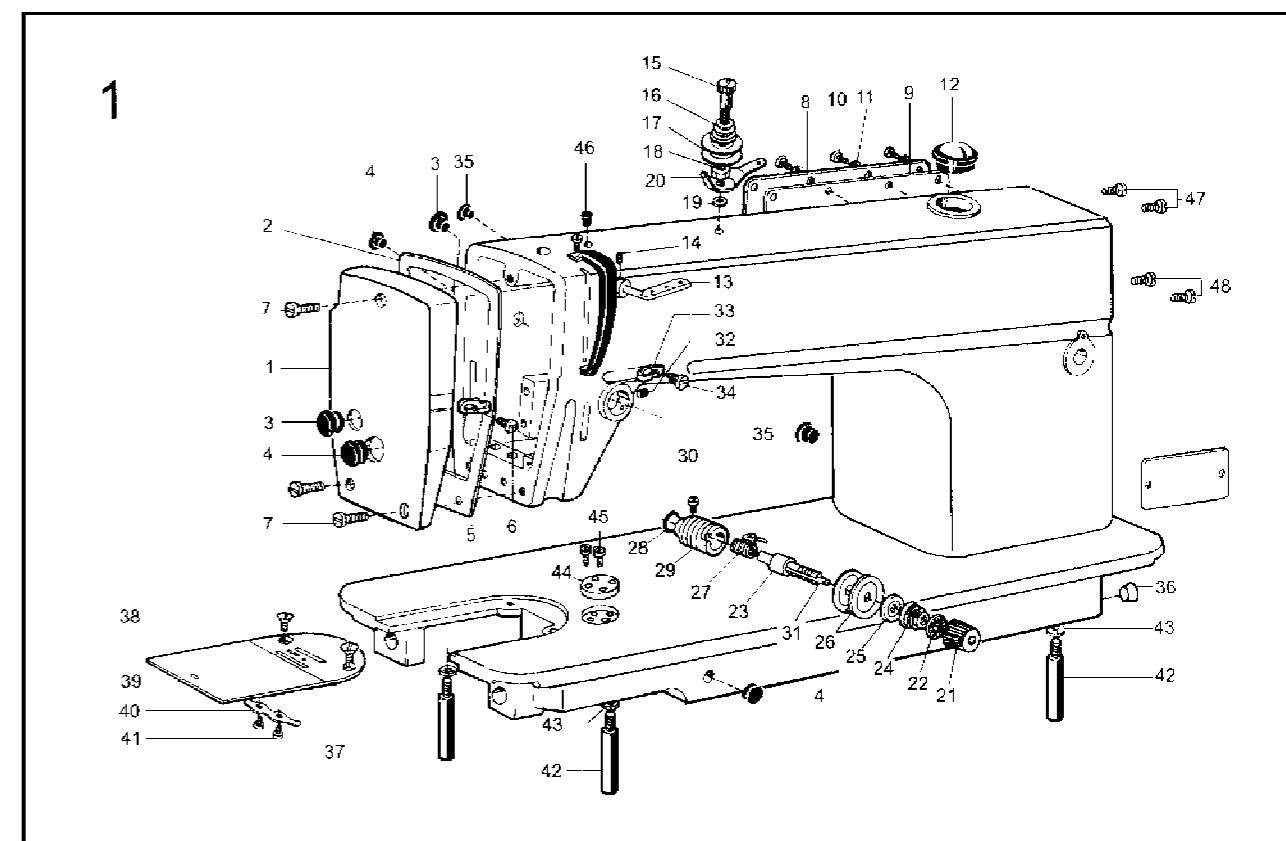

1. ARM BED AND ITS ACCESSORIES

No.	Ref. No.	Description	Qt.			No.	Ref. No.	Description	Qt.		
			M	H	B				M	H	B
1	124120001	Face plate	1	1	1	25	022160004	Thread tension releasing disc	1	1	1
2	124120002	Gasket for Face plate	1	1	1	26	022160005	Thread tension disc	2	2	2
3	022130003	Rubber plate	2	2	2	27	022160006	Thread take-up spring	1	1	1
4	022130004	Rubber plate	3	3	3	048110002	Thread take-up spring	1	1	1	
5	022130005	Thread guide on face plate	1	1	1	28	022160011	Rubber ring	1	1	1
6	022130006	Thread guide screw	1	1	1	29	022160007	Thread tension regulating bushing	1	1	1
7	022100004	Face plate screw	3	3	3	30	022160008	Set screw	1	1	1
8	022140001	Back plate	1	1	1	31	022160009	Thread tension releasing pin	1	1	1
9	022140002	Gasket for rack plate	1	1	1	32	022100013	Set screw	1	1	1
10	022100006	Set screw	8	8	8	33	022100014	Thread guide for arm center	1	1	1
11	022100007	Washer	8	8	8	078100005	Thread guide for arm center	1	1	1	
12	022180001	Oil check window	1	1	1	34	022130006	Set screw	1	1	1
13	022100010	Three hole thread guide	1	1	1	35	022100015	Rubber plug	2	2	2
14	124100006	screw	1	1	1	36	022100015	Rubber plug	1	1	1
15	022150001	Spring for pre-tension	1	1	1	37	124100005	Needle plate	1	1	1
16	022150002	Discs for pre-tension	2	2	2	048100004	Needle plate	1	1	1	
17	022150003	Washer	1	1	1	38	022100020	Needle plate screw	2	2	2
18	022150004	Spring washer	1	1	1	39	022170001	Slide plate	1	1	1
19	S4A0105006	Leg	1	1	1	40	022170002	Spring for slide plate	1	1	1
20	022150005	Thread guide for pre-tension	1	1	1	41	022170003	Screw	2	2	2
21	124130001	Knub for thread tension regulator	1	1	1	42	048100005	Washer	3	3	3
22	022160010	Thumb nut revdution stoper	1	1	1	43	S4A0400011	Washer	2	2	2
23	022160001	Thread tension stud	1	1	1	44	057100008	Ruler plate	1	1	1
24	124130002	Thread tension spring	1	1	1	45	124100004	Ruler screw	2	2	2
	048110001	Thread tension spring	1	1	1	46	022100017	Red rubber plug	1	1	1
						47	036550005	Screw	2	2	2
						48	022900006	Screw	2	2	2

