

GN2000

INSTRUCTION BOOK // PARTS CATALOGUE

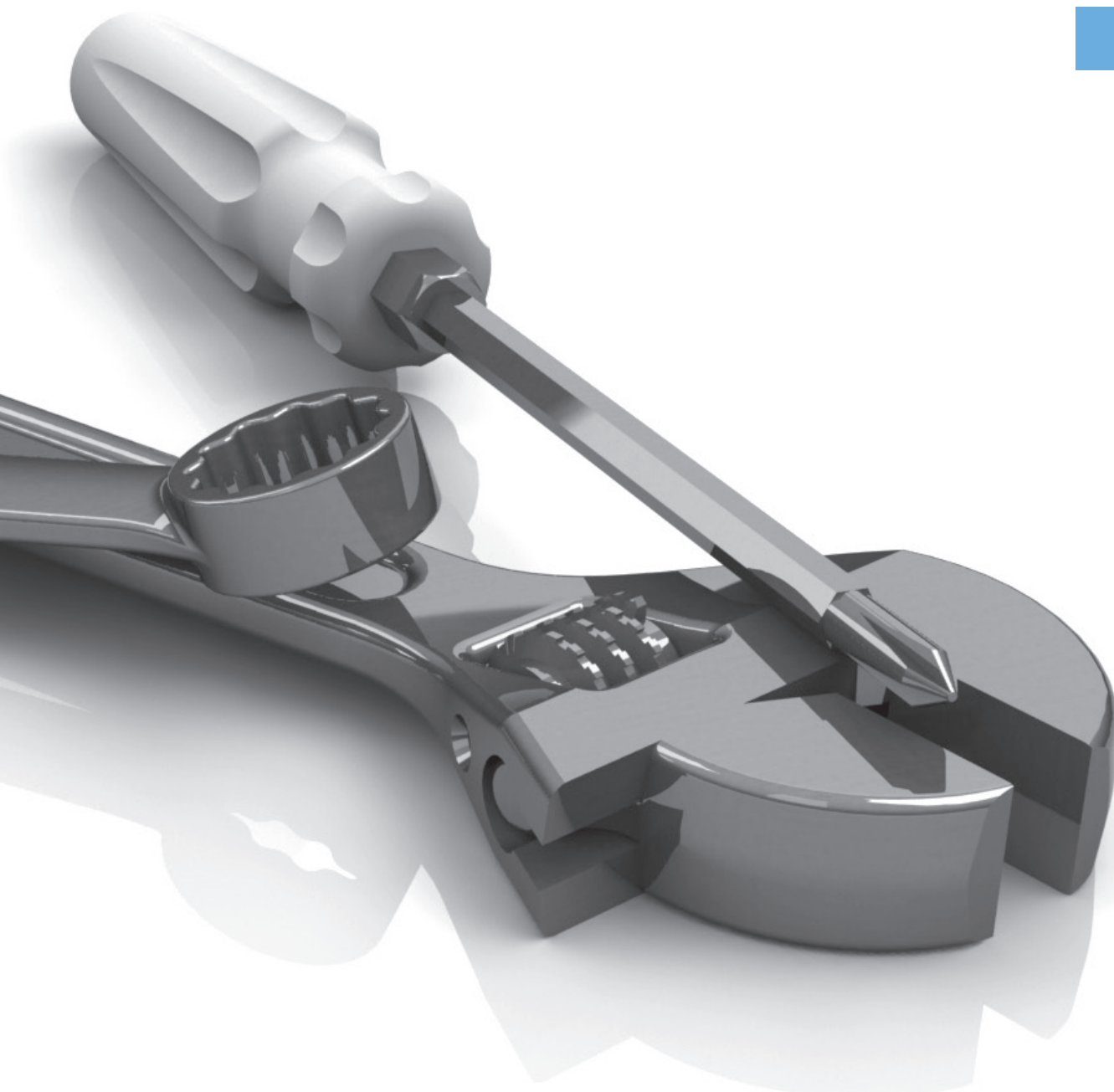

HIGH-SPEED OVERLOCK SEWING MACHINE



TYPICAL

INTRODUCTION

Thank you very much for purchasing 2000 Series sewing machine.

This instruction manual describes daily routine maintenance and safety precautions to keep the machine in the best possible conditions.

Please study this manual very carefully before operating the machine.

OBSERVE THESE SAFETY PRECAUTIONS

Though 2000 series takes the utmost care to produce safe sewing machines and devices, operators should follow these basic safety rules.

- To prevent accidents, do not remove safety devices or parts while operating the machine.
- Do not leave tools or other unnecessary objects on the machine table while operating the machine.
- Before maintenance, adjusting, cleaning, threading or replacing the needle, and to prevent accidents, be sure the power is turned off. Check that the machine will not operate when the pedal is pressed.

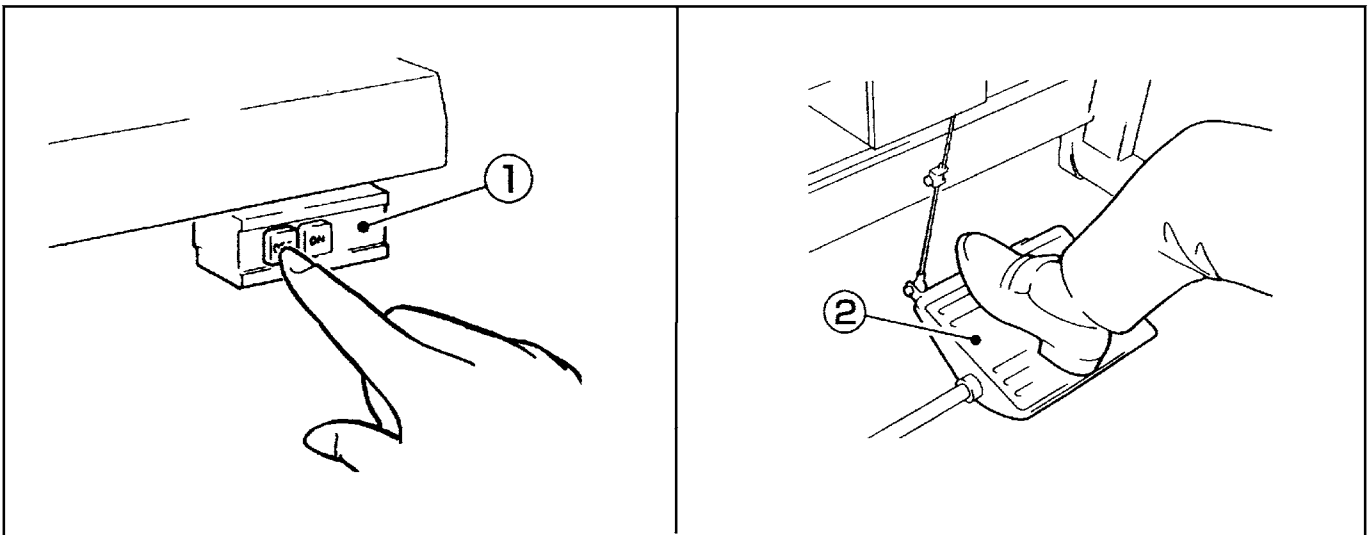

Note

In case a clutch type motor is used, it will keep on rotating by inertia after turning off power supply ①. If the machine pedal ② is stepped on inadvertently, it is dangerous because the machine will move unexpectedly. Keep on stepping on the machine pedal ② until the machine comes to a stop after turning off the power supply ①.

- Turn the power off before leaving the machine table.

- In the event of a power failure, be sure to turn the machine off.

- Check that the machine is securely grounded.

CONTENTS

■ BEFORE OPERATING

Schematic diagram of the machine table	3
Installing the machine head	4
The machine speed and the turning direction	4
Lubrication	5
Manual lubrication	5
Filling the HR device with silicon oil	6
Threading	6

■ TEST SEWING

Adjusting the presser foot pressure	7
Adjusting the diff. feed ratio	8
Adjusting the stitch length	8
Adjusting the thread tension	9

■ MAINTENANCE DURING USE

Cleaning the machine	9
Replacing the needle	10
The check of the filter fix and replace	10
Checking the oil circulation	11
Replacing the oil	11
Replacing the lower knife	12 – 13
Adjustment dimensions	13
Standard needle	13

Schematic diagram of the machine table

Cut the table referring to the diagram .

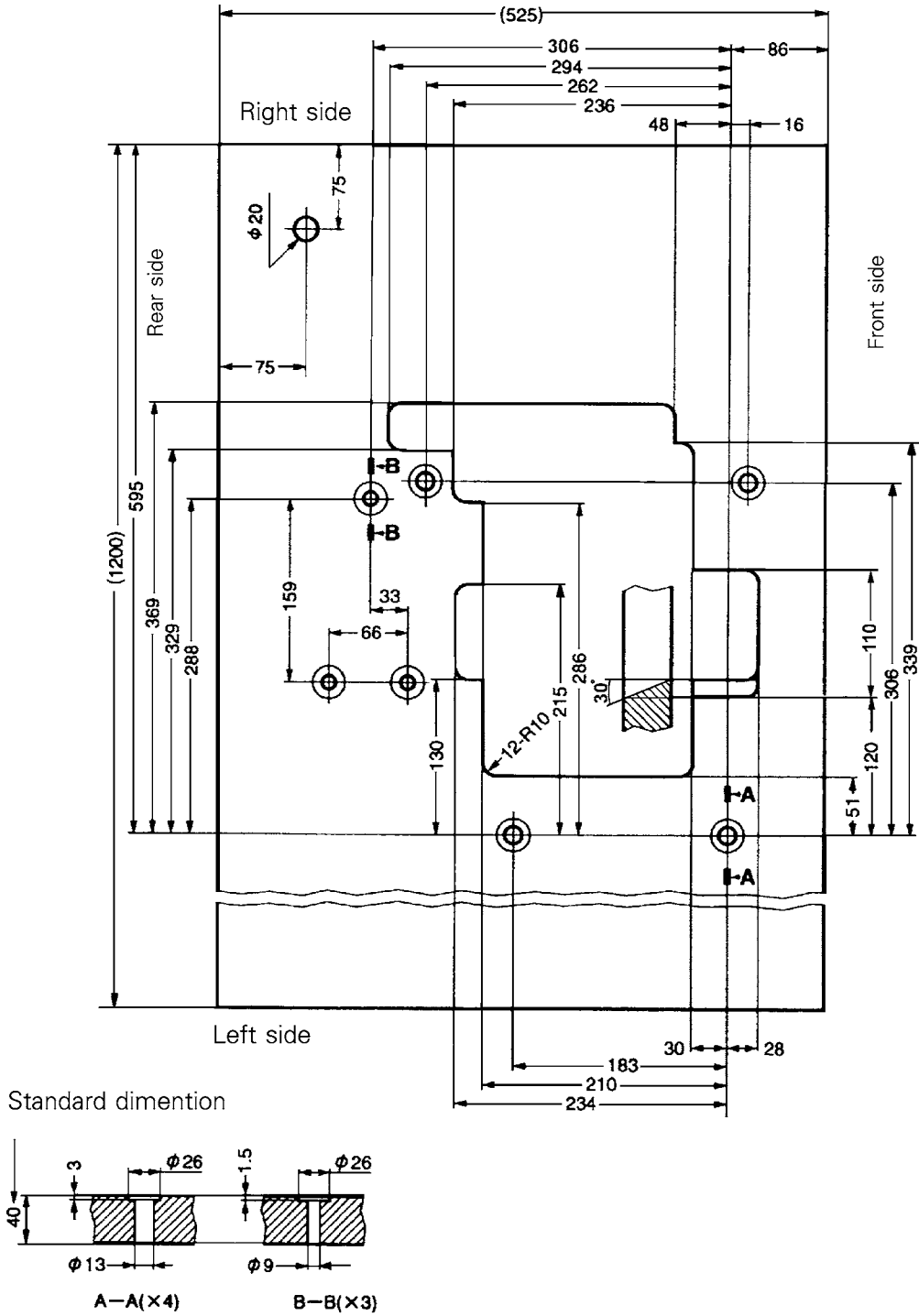

BEFORE OPERATING

Instaling the machine head

1. Mount the machine head on the mahcine rest board.
2. Adjust the tension of the belt so that it can be about 2cm bent inward when you press the middle of it.
Adjust the height of the motor to do this.
3. Install the belt cover referring to the Figure.

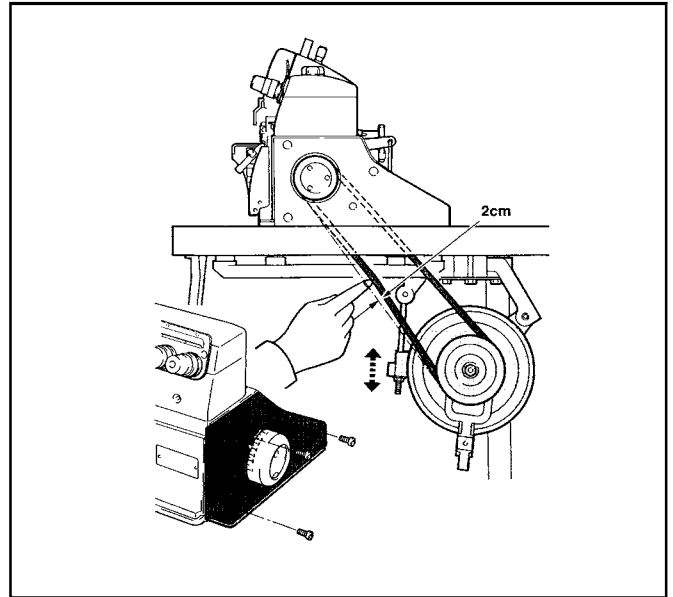

BEFORE OPERATING

The machine speed and turning direction

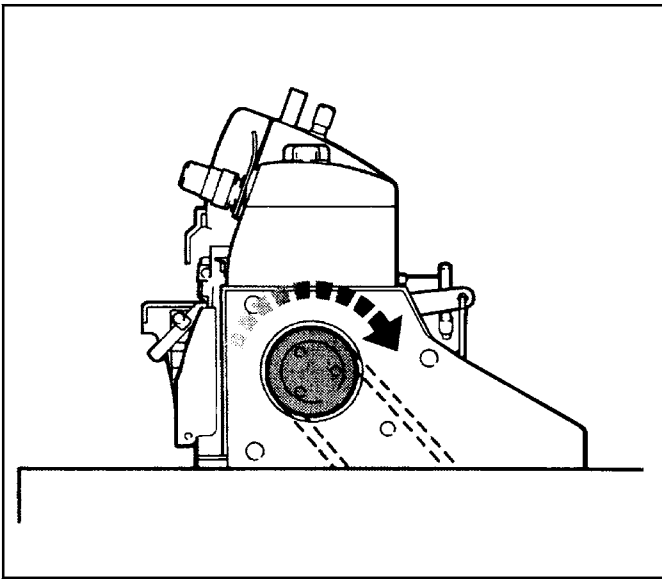

The machine rotates clockwise when seen from the machine pully side.

Make sure your machine type and run it not exceeding the maximum speed as listed in the table.

Mode	(r. p. m) Sewing speed(max)
2000 - 3 2000 - 3B 2000 - 3E	7000
2000 - 4 2000 - 4M	6500
2000 - 4H	6000
2000 - 5L 2000 - 5 2000 - 5(5 × 5)	6500
2000 - 5H	5500

BEFORE OPERATING

Lubrication

After filling the oil pan, the top of oil indicator should lie between (H) and (L) lines.

Add oil, when it reaches or goes below (L).

Note: Use our company recommended oil.

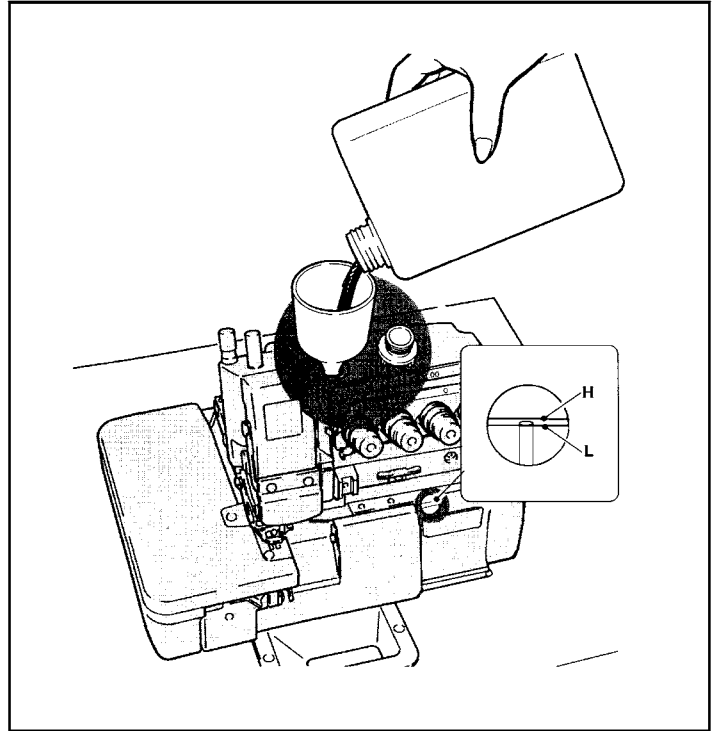

BEFORE OPERATING

Manual lubrication

Apply 2 or 3 drops of oil by hand when the machine is used for the first time or has been left unused for some time.

Note: Use our company recommended oil.

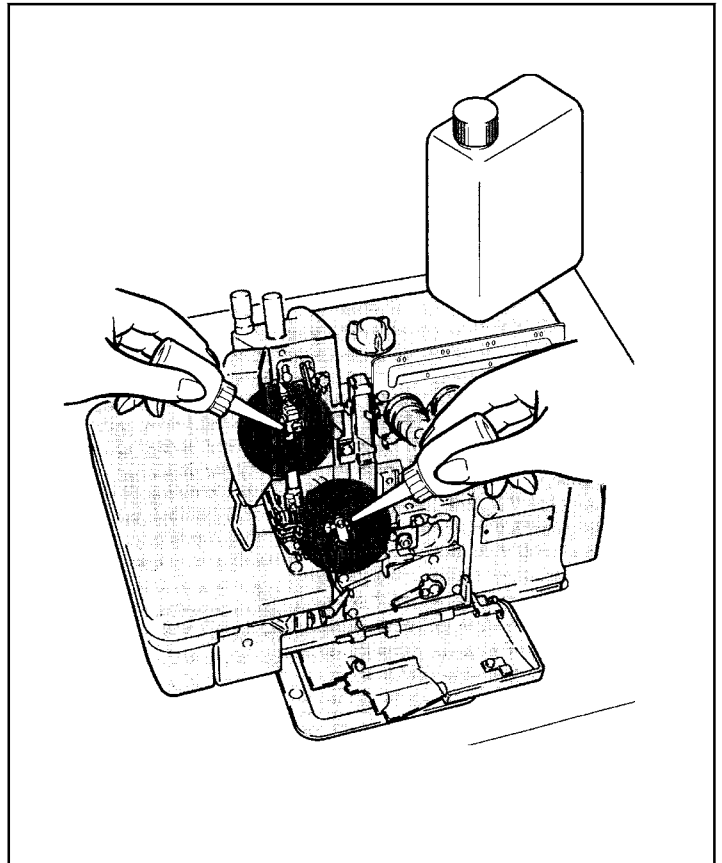

BEFORE OPERATING

Filling the HR device with silicon oil

Fill the HR device with oil before it is too low in order to prevent needle thread breakage and fabric damage.

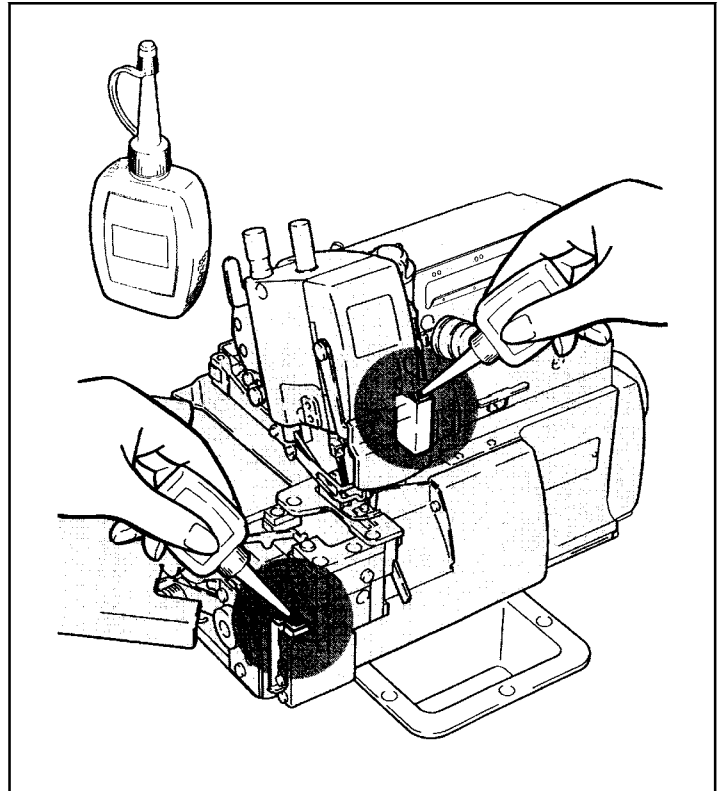

BEFORE OPERATING

Threading

Open three covers.
Swing the presser foot aside.

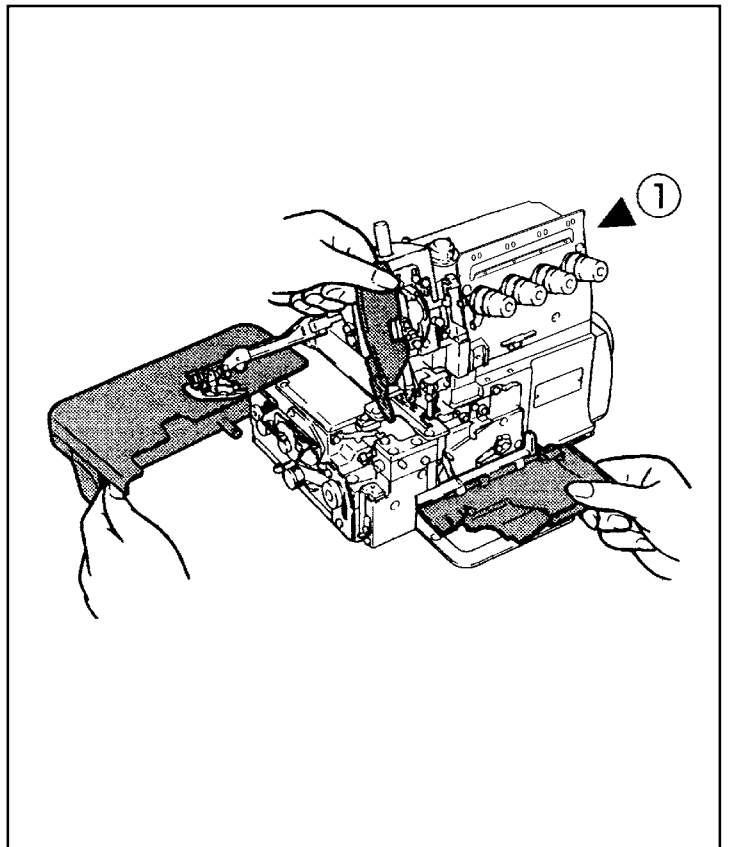

Threading

Needle thread

Trim the knots off neatly before passing through the eye of the needle to rethread.

Knot the preset thread and the thread being used together to thread the machine.

②

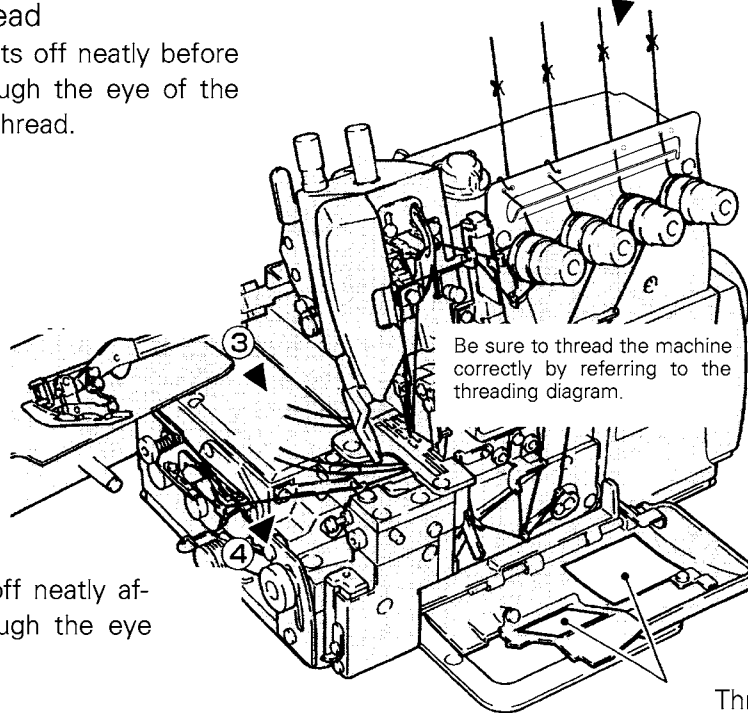

Looper thread

Trim the knots off neatly after passing through the eye of the looper.

Threading diagram

Adjusting the presser foot pressure

Turn adjusting screw to adjust the presser foot pressure. It should be as light as possible, yet be sufficient to obtain the proper stitch formation.

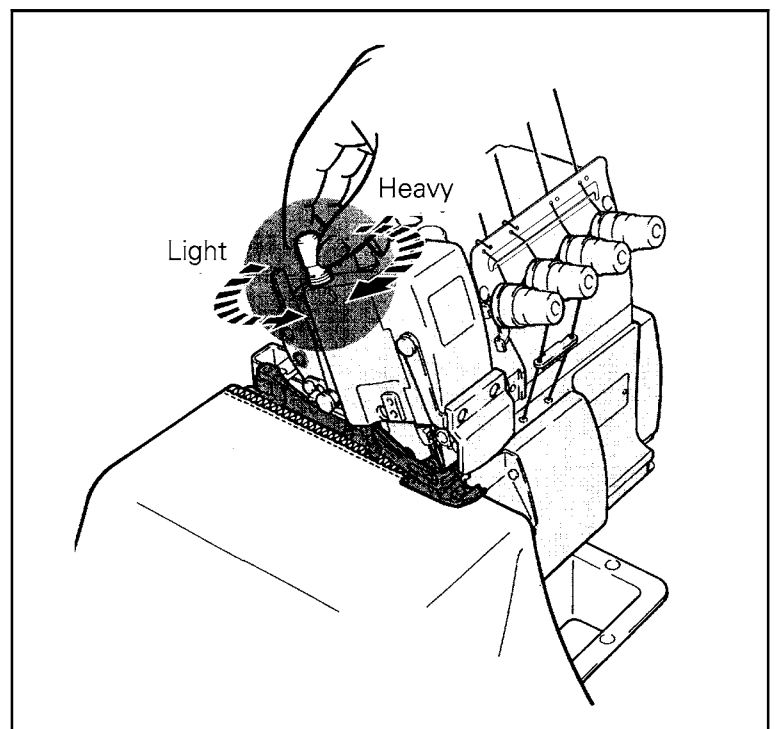

Adjusting the diff. feed ratio

Loosen the nut and move the lever up and down to obtain the correct differential feed ratio.

Tighten the nut after positioning the lever as desired.

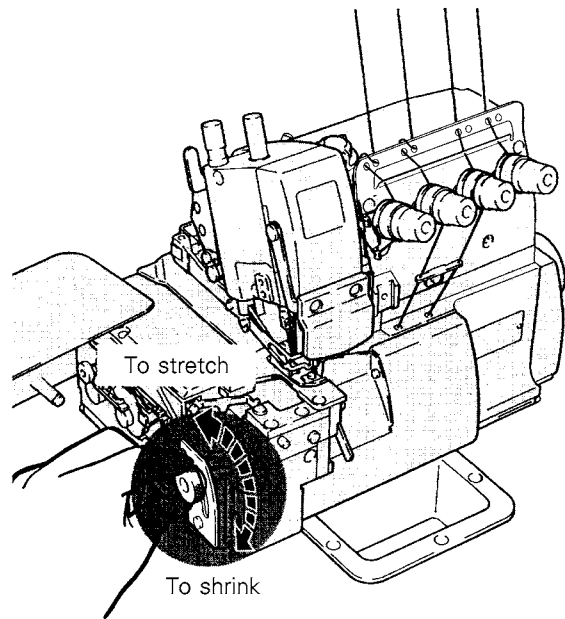

Adjusting the stitch length

1. While pressing the push button, turn the handwheel to seek the position at which the push button goes further into the depth.

2. Then, keeping the push button pressed, turn the handwheel and set the desired scale to the aligning mark.

Note: Stitch length adjustment must only be made after the differential feed ratio has been changed.

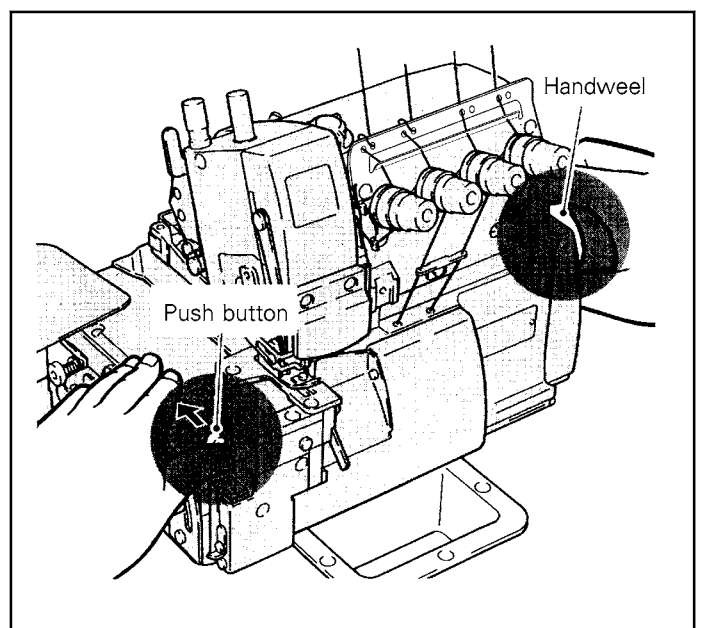
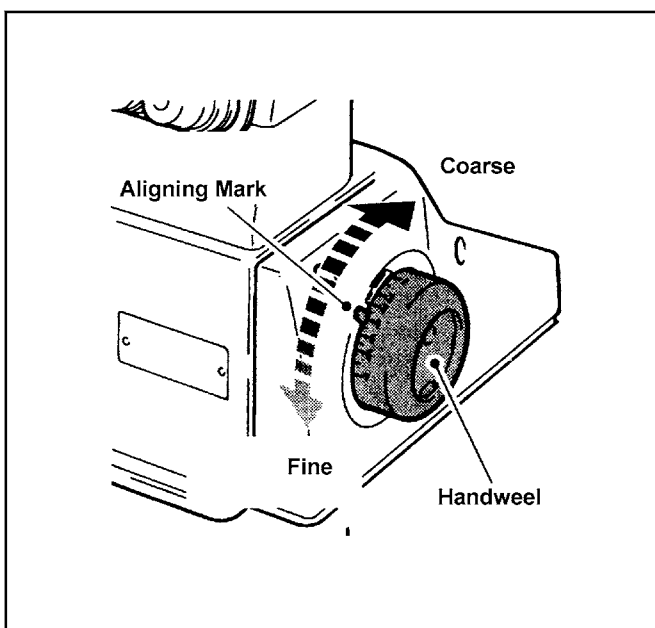

TEST SEWING

Adjusting the thread tension

Make tension adjustments with the needle thread knot ①, the upper looper knob ②, and the lower looper knob ③.

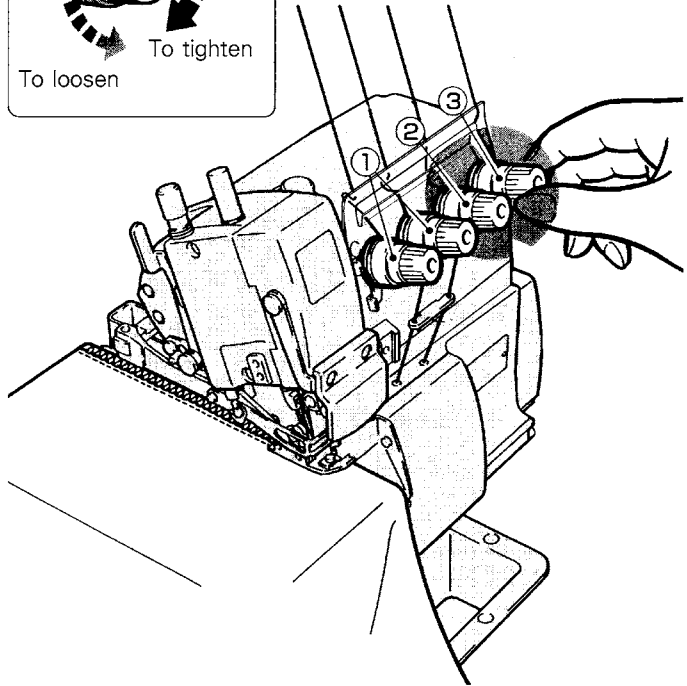
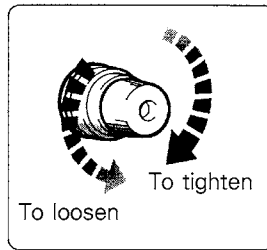

MAINTENANCE
DURING USE

Cleaning the machine

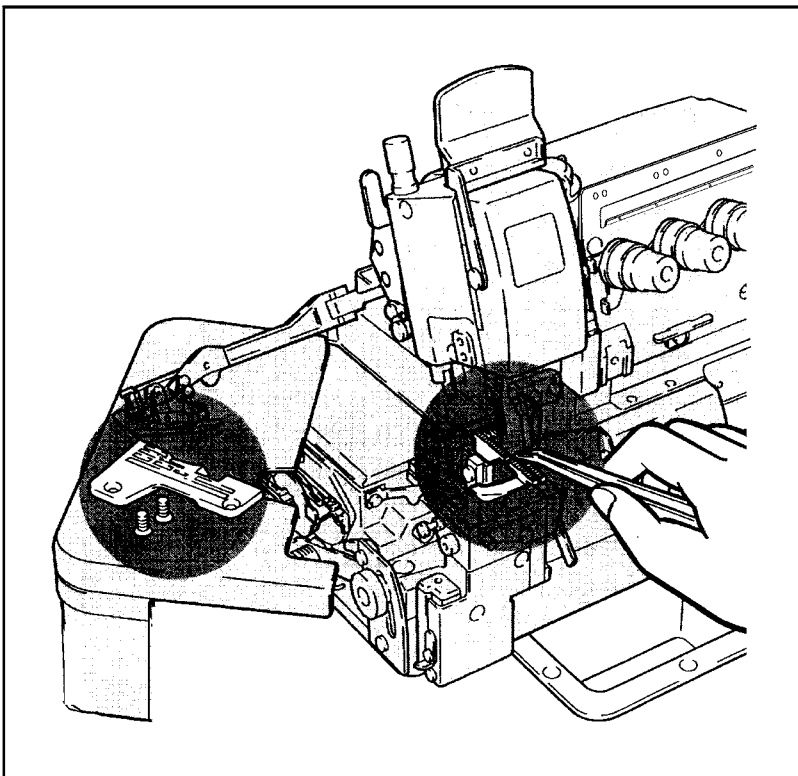

Mainly the slots of the needle plate and the feed rows should be cleaned.

Replacing the needle

Check the needle carefully to see that the scarf is turned to the rear of the machine. Insert the needle to the proper depth, and fasten securely.

Be sure to use standard needle. Refer to ADJUSTMENT DIMENSIONS on the end of instructions.

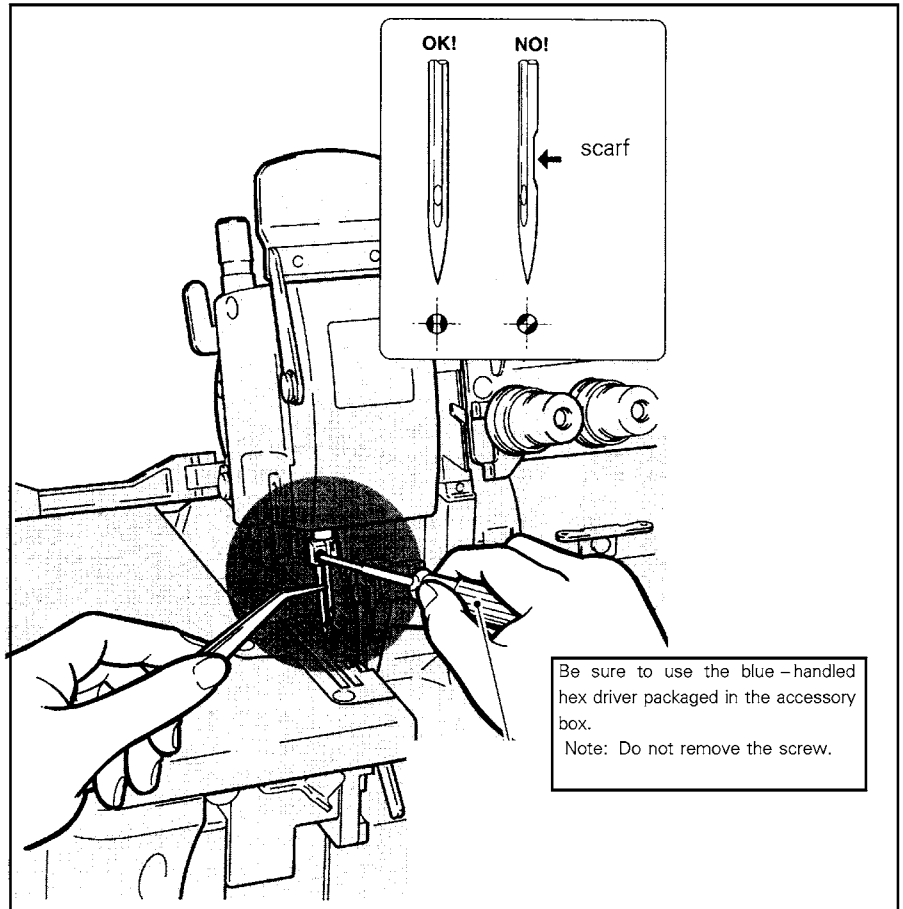

The check of the filter fixs and replace

Turn off the power before checking filter and replacing, You'd better appeal for aid to a professional technical person.

If the filter is jammed by debris, oil circulation will be break off. For the sake of working order, please clean up the trash or change a new one each 6 months.

As shown on the right, fixed disassembly order of filter likes this:

1. Top cover
2. Screw
3. The cover of oil basin
4. Rubber ring
5. Filter
6. Check the filer , if the filter has been dilapidate, replace it.

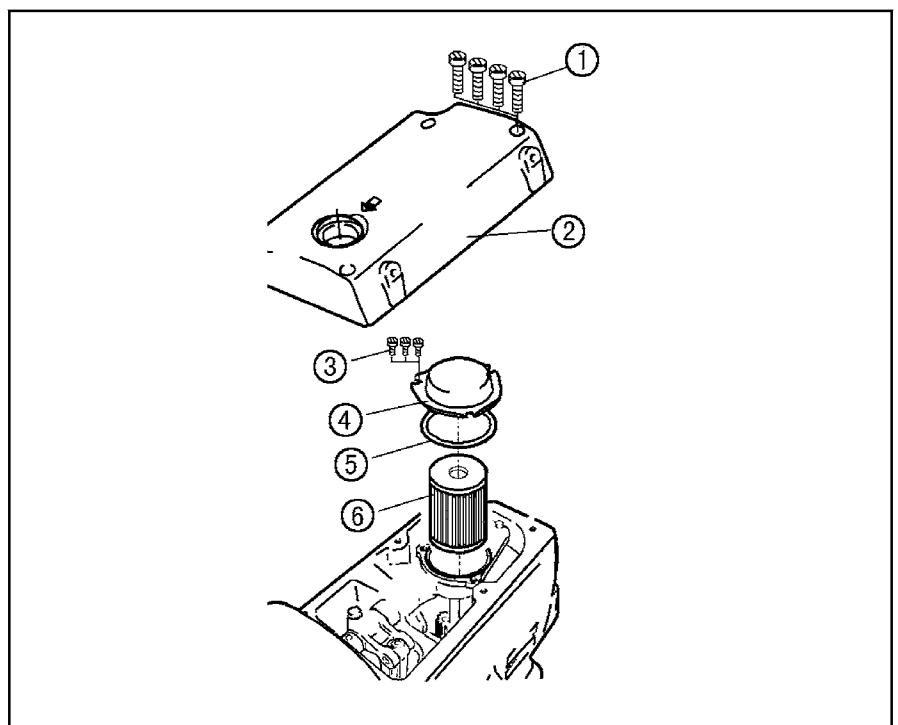

MAINTENANCE
DURING USE

Checking the oil circulation

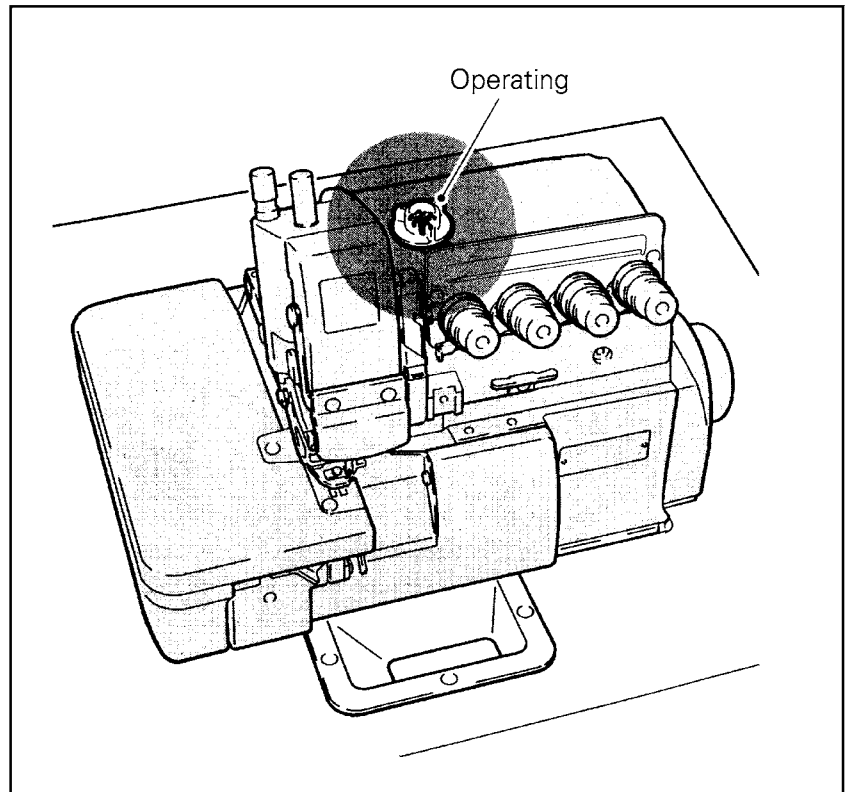

MAINTENANCE
DURING USE

Replacing the oil

Replace the oil one month after the first use and every six months thereafter.

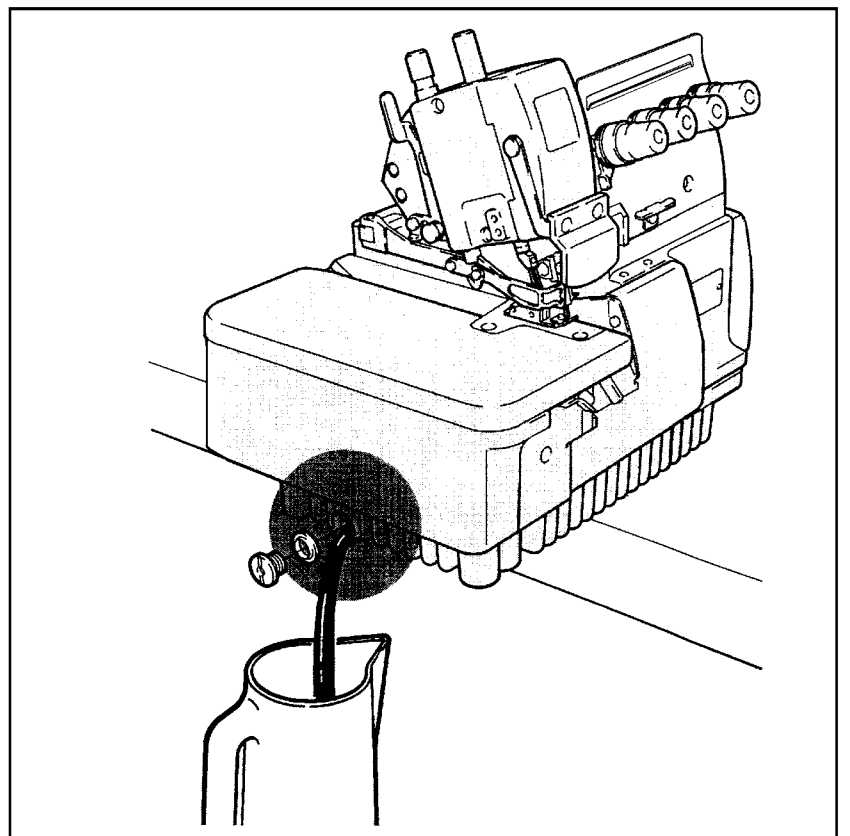

Replacing the lower knife

To remove the lower knife

Temporarily screw ① after sliding the lower knife holder to the left.

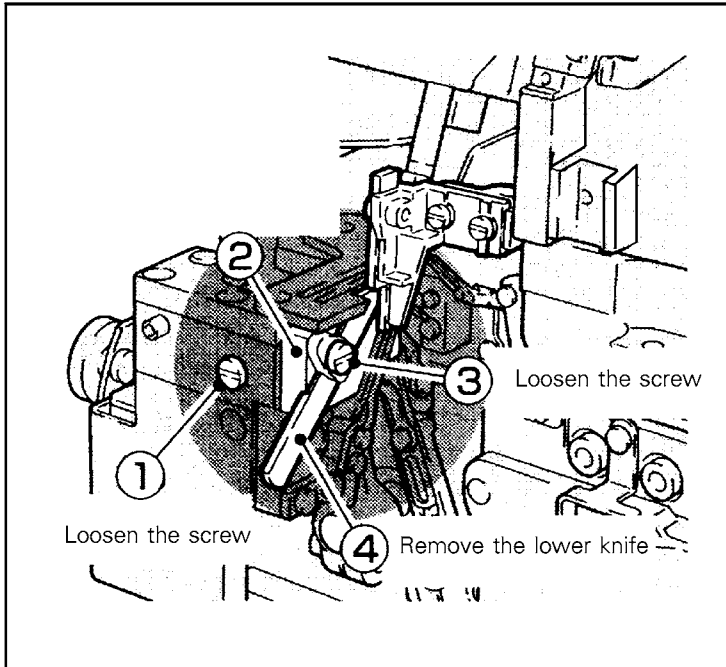

Correct angles to sharpen the lower knife.

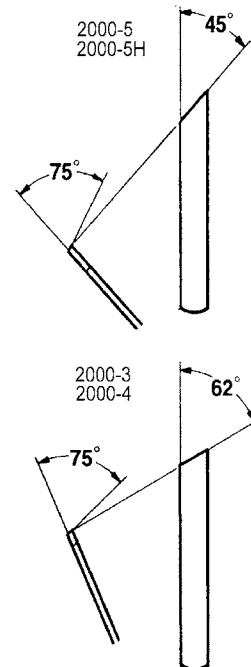

To replace the lower knife

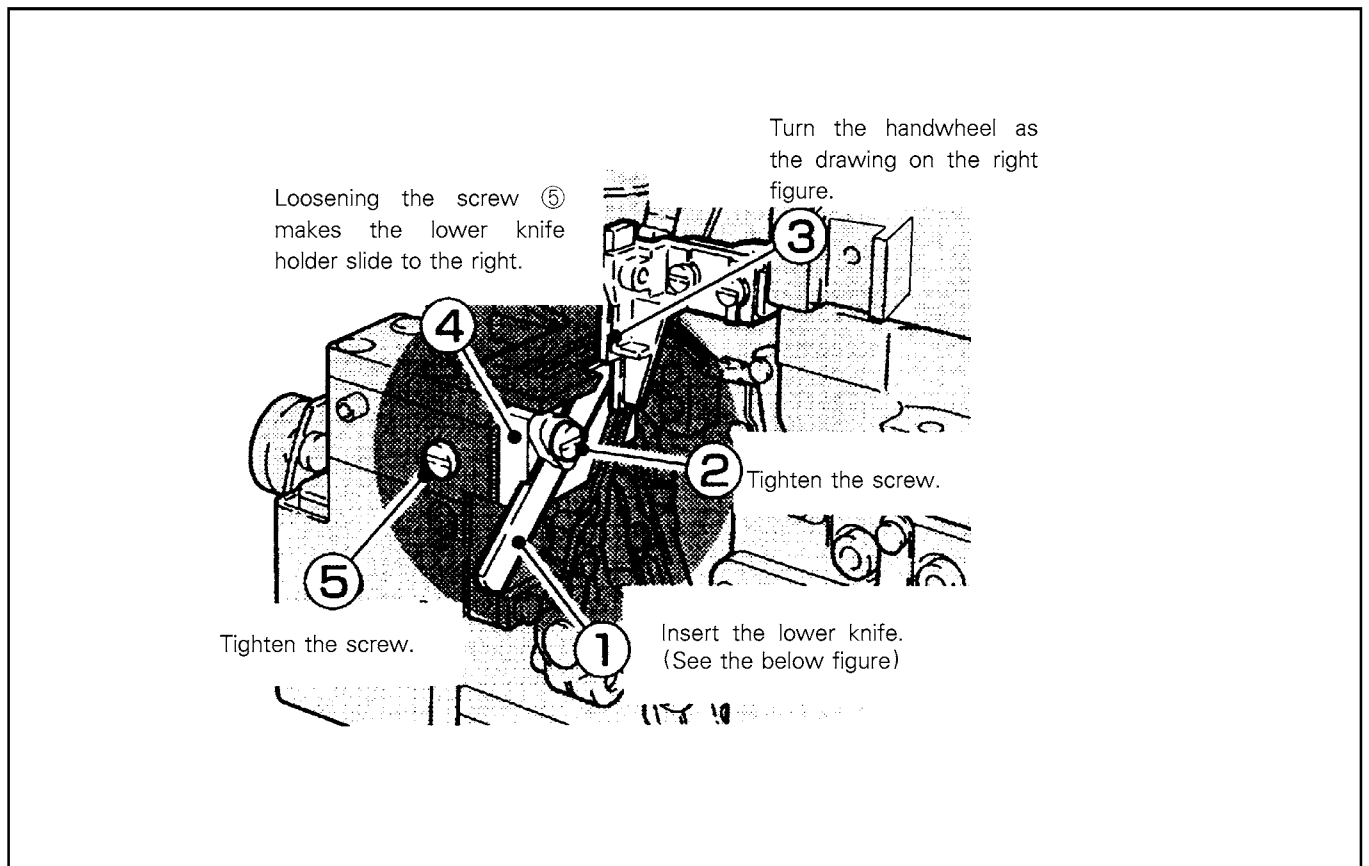

Replacing the lower knife

Level of A = Level of B
Check cutting action of knives.

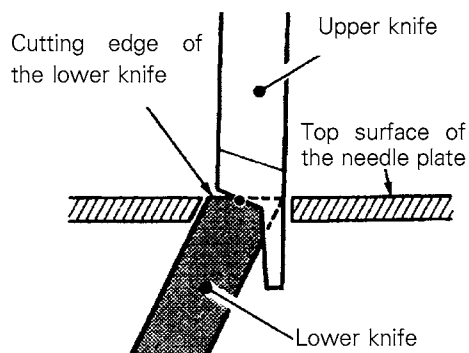

Adjustment dimensions 2000-5 (mm)

2000-5L	10.6	3.9	5.1	0.9-1.1	5.5	1.5		
2000-5	10.6	3.9	3.3	0.9-1.1	5.5	1.5		
2000-5(5x5)	10.6	3.9	5.1	0.9-1.1	5.5	1.5		
2000-5H	12.0	3.6	5.1	0.9-1.1	6	1.5		

Adjustment dimensions 2000-3, 2000-4 (mm)

2000-3	10.1	4.2	5.1	0.9-1.1	5.5			
2000-3B	10.1	4.2	5.1	0.9-1.1	5.5			
2000-3E	10.1	4.2	5.1	0.9-1.1	5.5			
2000-4	10.1	4.6	5.8	0.9-1.1	5.5			
2000-4H	11.1	4.6	5.8	0.9-1.1	6			

2000 Standard needle

	Organ DC × 27
2000 - 3	11
2000 - 3B	9
2000 - 3E	9
2000 - 4	11

	Organ DC × 27
2000 - 4H	14
2000 - 5L	11
2000 - 5	14
2000 - 5(5 × 5)	14
2000 - 5H	21

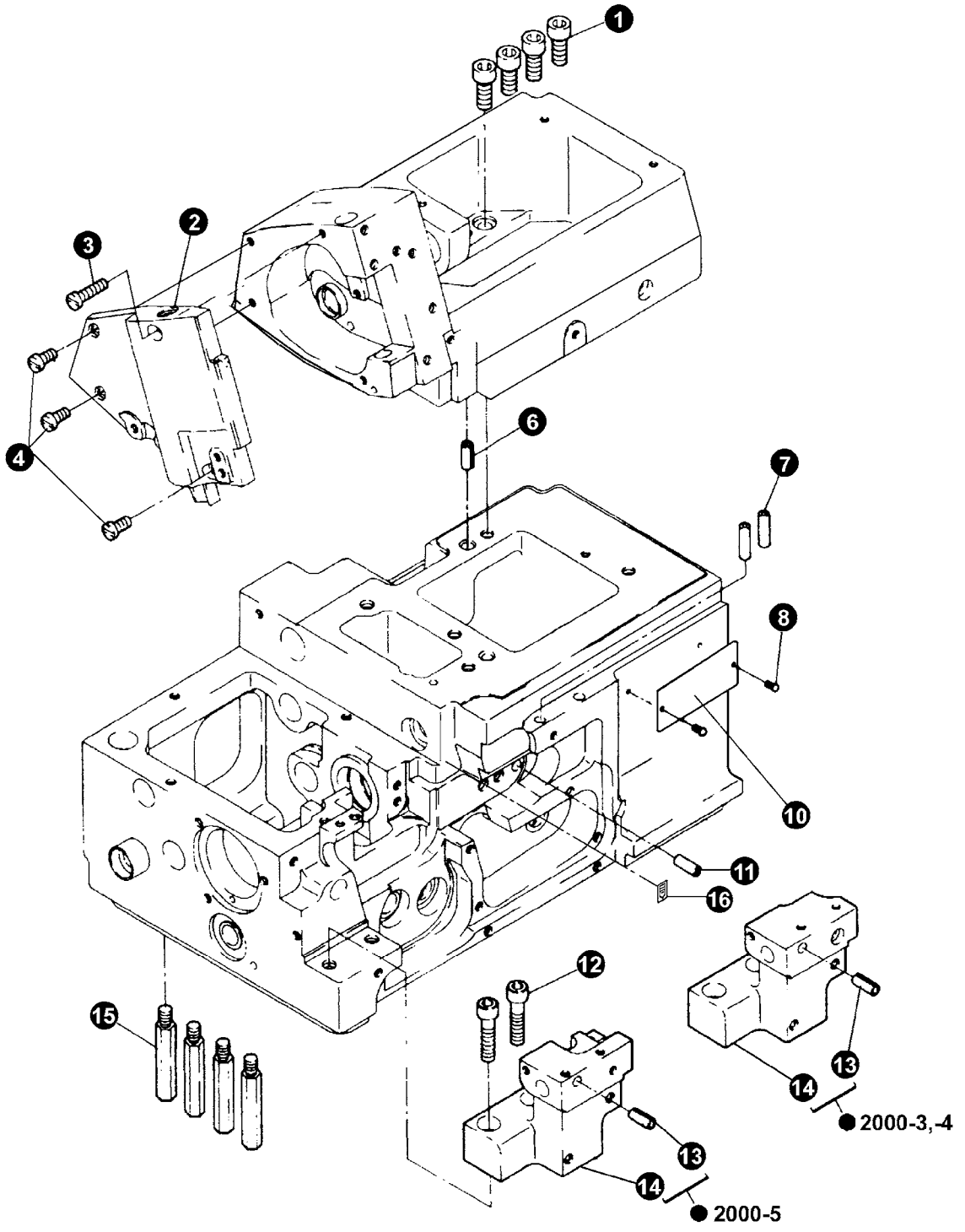

1. MACHINE ARM PARTS(1)

No	Ret. No.	Description	Qt			
			3	4/4H	5	5H
1	S150220005	Screw	4	4	4	4
2	155100001	Frame side cover	1	1	1	1
3	S150215011	Screw(L)	1	1	1	1
4	S150215009	Screw(S)	3	3	3	3
6	S8A3104007	Spring pin	2	2	2	2
7	155100002	Thread guide pipe	2	2	2	2
8	BXF8899009	Rivet	2	2	2	2
10	198000014	Model plate	1			
11	S8A3104007	Spring pin	1	1	1	1
12	S150220016	Screw	2	2	2	2
13	S8A3104007	Spring pin	1	1	1	1
14	159100001	Needle plate support bracket	1	1		
	155100003	Needle plate support bracket			1	1
15	155100005	Screw	4	4	4	4
16	155100041	Oil mark	1	1	1	1

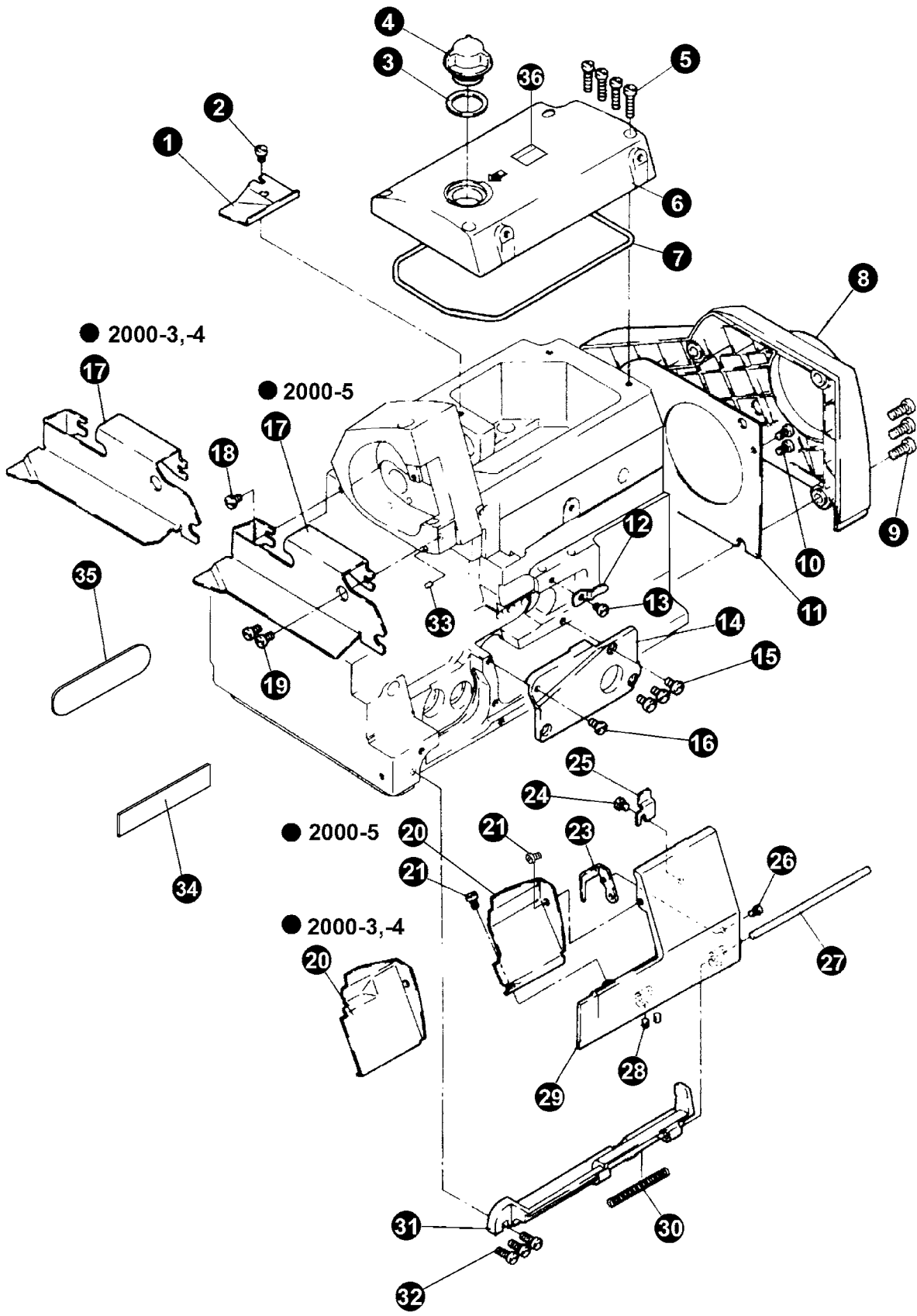

2. MACHINE ARM PART(2)

No	Ret. No.	Description	Qt			
			3	4/4H	5	5H
1	155100010	Oil guide plate	1	1	1	1
2	S150215008	Screw	1	1	1	1
3	155100031	Packing	1	1	1	1
4	155100030	Oil monitor	1	1	1	1
5	S150215011	Screw	4	4	4	4
6	155100008	Top cover	1	1	1	1
7	155100009	Oil gasket	1	1	1	1
8	155100016	Belt cover	1	1	1	1
9	S150215014	Screw	3	3	3	3
10	S150215001	Screw	2	2	2	2
11	155100015	Cooling fan guard	1	1	1	1
12	155100013	Plate spring	1	1	1	1
13	S150215008	Screw	1	1	1	1
14	155100014	Cover	1	1	1	1
15	S150215001	Screw	3	3	3	3
16	155100034	Screw	1	1	1	1
17	159140000	Cloth guide	1	1		
	155150000	Cloth guide			1	1
18	155100033	Screw	1	1	1	1
19	S150215001	Screw	2	2	2	2
20	159120001	Front cover	1	1		
	155120004	Front cover			1	1
21	S150215008	Screw	2	2	2	2
23	155120007	Front cover hinge stopper	1	1	1	1
24	S150215008	Screw	1	1	1	1
25	155120005	Stopper plate	1	1	1	1
26	S120202007	Screw	1	1	1	1
27	155120002	Front cover hinge shaft	1	1	1	1
28	B12400432	Screw	2	2	2	2
29	155120001	Front cover(L)	1	1	1	1
30	155120003	Spring	1	1	1	1
31	155120006	Front cover hinge	1	1	1	1
32	S150215010	Screw	3	3	3	3
33	155100012	Oil seal	1	1	1	1
34	160DQZ005	Decorative brand	1	1	1	1
35	160DHZ001	Decorative brand	1	1	1	1
36	155100046	Oil filter tags	1	1	1	1

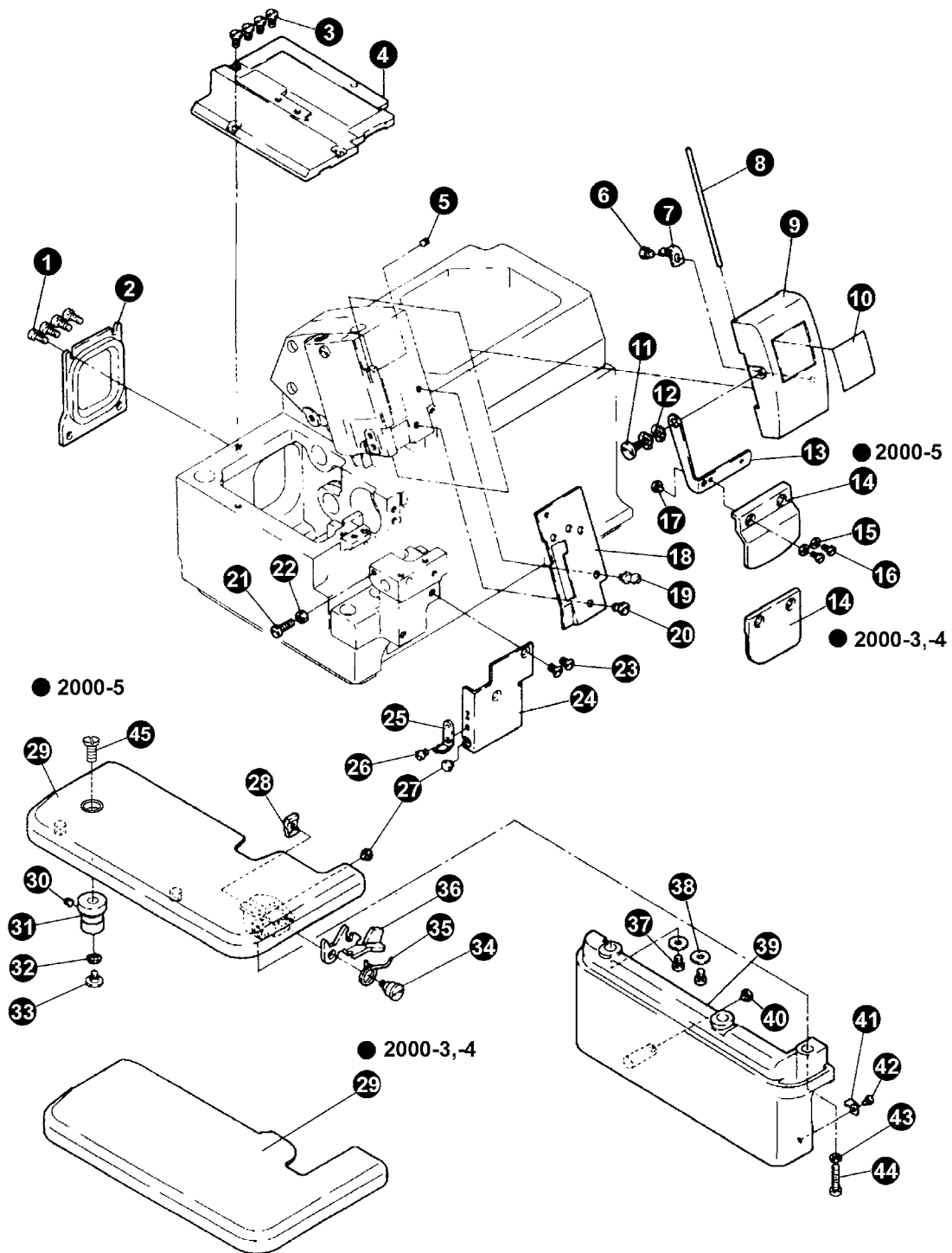

3. MACHINE ARM PART(3)

No	Ret. No.	Description	Qt			
			3	4/4H	5	5H
1	S150215009	Screw	4	4	4	4
2	155100017	Back cover for feed mechanism	1	1	1	1
3	155100033	Screw	4	4	4	4
4	155100018	Feed bar cover	1	1	1	1
5	B12400432	Screw	1	1	1	1
6	S150215008	Screw	1	1	1	1
7	155100021	Plate spring	1	1	1	1
8	155100020	shaft for needle thread cover	1	1	1	1
9	155100019	Needle thread cover	1	1	1	1
10	160DQZ002	Trade mark plate	1	1	1	1
11	155100024	Screw	1	1	1	1
12	155100025	Wave spring	2	2	2	2
13	155100023	Eye guard support plate	1	1	1	1
14	159100004	Eye guard	1	1		
	155100026	Eye guard			1	1
15	S8A3103002	Washer	2	2	2	2
16	S120202007	Screw	2	2	2	2
17	155100027	Rubber plug	1	1	1	1
18	155100029	Needle bar seal cover	1	1	1	1
19	155100022	Screw	1	1	1	1
20	155100034	Screw	1	1	1	1
21	S150215005	Screw	1	1	1	1
22	S150559002	Nut	1	1	1	1
23	S150218005	Screw	2	2	2	2
24	155140001	Direction guide plate	1	1	1	1
25	155140002	Plate spring	1	1	1	1
26	S150217008	Screw	1	1	1	1
27	155100027	Rubber plug	3	3	3	3
28	155130006	Nut	1	1	1	1
29	159131001	Cloth plate	1	1		
	155131001	Cloth plate			1	1
30	B12400432	Screw	1	1	1	1
31	155130001	Cloth plate shaft bush	1	1	1	1
32	155100025	Wave spring	1	1	1	1
33	155100024	Screw	1	1	1	1
34	155130005	Screw	1	1	1	1
35	155130004	Spring	1	1	1	1
36	155130003	Latch lever for cloth plate	1	1	1	1
37	S150215001	Screw	2	2	2	2
38	155130008	Washer	2	2	2	2
39	155130007	Side cover	1	1	1	1
40	155100027	Rubber plug	1	1	1	1
41	155130009	Plate spring	1	1	1	1
42	S120202004	Screw	1	1	1	1
43	S4B3000010	Spring washer	1	1	1	1
44	S150215005	Screw(L)	1	1	1	1
45	116400008	Screw	1	1	1	1

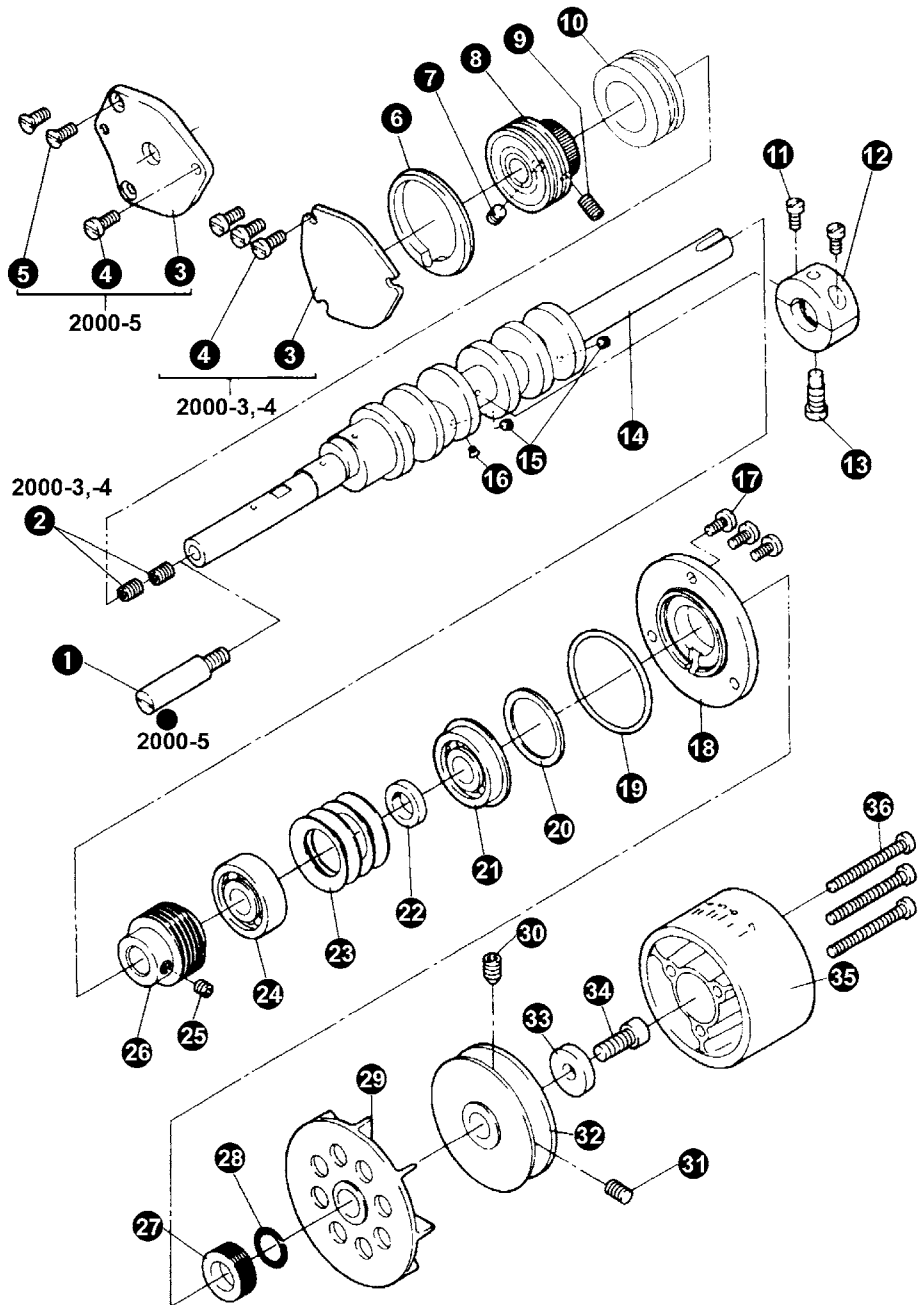

4. NEEDLE BAR DRIVE PARTS(1)

No	Ret. No.	Description	Qt			
			3	4/4H	5	5H
1	155200001	Crank shaft extension			1	1
2	S150224007	Screw	2	2		
3	159200001	Bearing cap	1	1		
	155200002	Bearing cap			1	1
4	S150215009	Screw	3	3		
	S150215009	Screw			1	1
5	S120205003	Screw			2	2
6	155200004	Rubber ring	1	1	1	1
7	B12500532	Screw	1	1	1	1
8	155220000	Ball bearing(L), assy	1	1	1	1
9	S150224006	Screw	1	1	1	1
10	155200005	Crank shaftbush(M)	1	1	1	1
11	SFB0201004	Screw	2	2	2	2
12	155230001	Stopper bush	1	1	1	1
13	155200006	Screw	1	1	1	1
14	155210001	Crank shaft	1	1	1	1
15	006301008	Screw	2	2	2	2
16	028260003	Screw	1	1	1	1
17	S150215009	Screw	3	3	3	3
18	155200011	Bearing presser	1	1	1	1
19	155200018	O – type ring	1	1	1	1
20	155200010	Packing	1	1	1	1
21	052200036	Ball bearing (right)	1	1	1	1
22	155200009	Collar	1	1	1	1
23	155200008	Spring washer	4	4	4	4
24	S150866046	Ball bearing (middle)	1	1	1	1
25	B12500532	Screw	1	1	1	1
26	155200007	Worm	1	1	1	1
27	155200012	Crank shaft oil reject	1	1	1	1
28	S150656004	O – type ring	1	1	1	1
29	155200013	Cooling fan	1	1	1	1
30	S150225003	Screw	1	1	1	1
31	S150224003	Screw	1	1	1	1
32	155200014	Belt wheel	1	1	1	1
33	155200016	Washer	1	1	1	1
34	S150220005	Screw	1	1	1	1
35	155200017	Machine pulley	1	1	1	1
36	S150215012	Screw	3	3	3	3

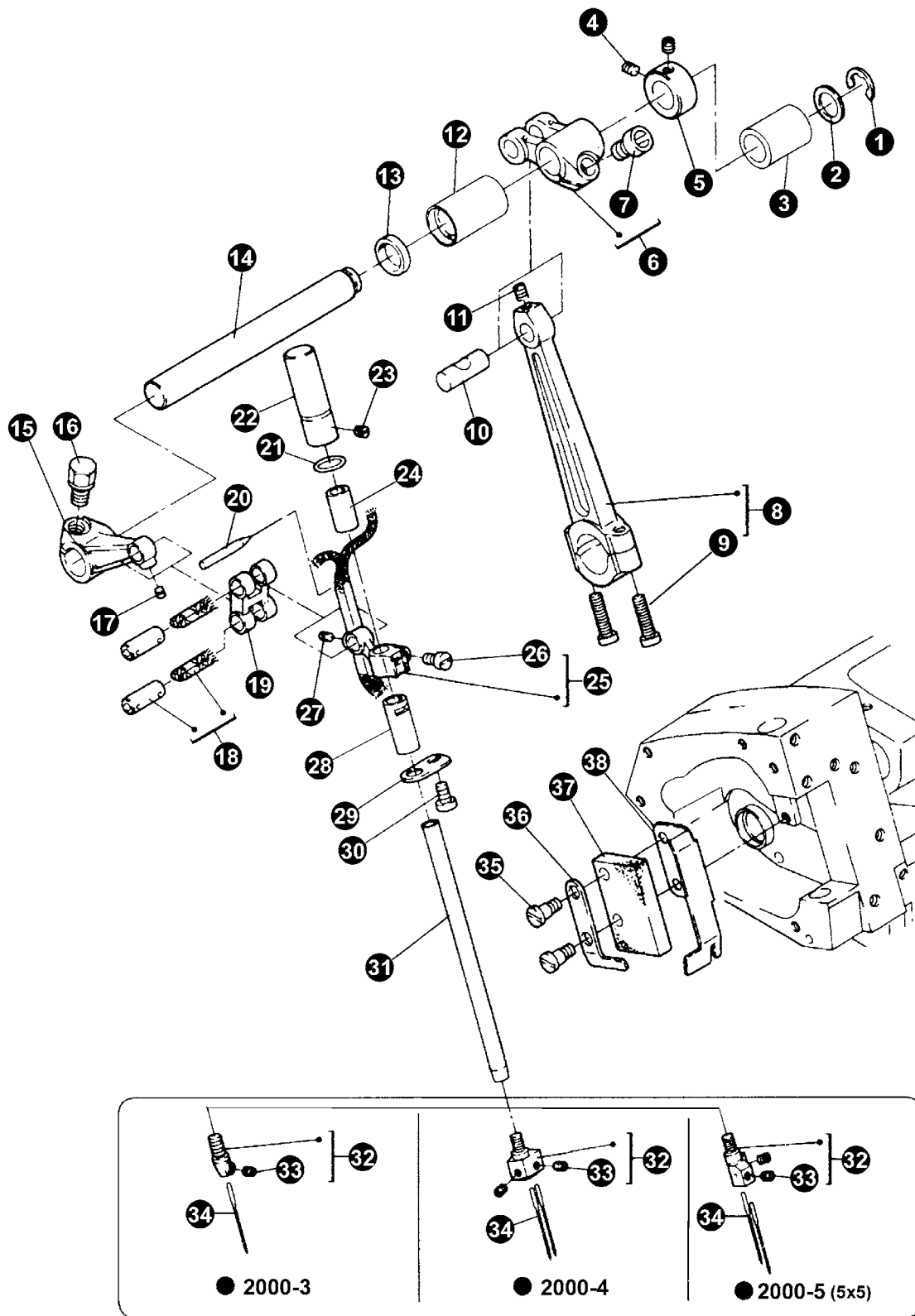

5. NEEDLE BAR DRIVE PARTS(2)

No	Ret. No.	Description	Qt				
			3	4	4H	5	5H
1	060410014	Retaining ring	1	1	1	1	1
2	155300006	Washer	1	1	1	1	1
3	155300005	Bush	1	1	1	1	1
4	B12400432	Screw	2	2	2	2	2
5	155300004	Set collar	1	1	1	1	1
6	155310000	Upper shaft crank complete	1	1		1	
	155370000	Upper shaft crank complete			1		1
7	155300017	Screw	1	1	1	1	1
8	155330000	Needle drive crank rod assy	1	1	1	1	1
9	B62401612	Screw	2	2	2	2	2
10	155300023	Pin	1	1	1	1	1
11	S150225008	Screw	1	1	1	1	1
12	155300002	Bush	1	1	1	1	1
13	155300003	Oil seal	1	1	1	1	1
14	155300001	Upper shaft	1	1	1	1	1
15	155300007	Needle bar crank	1	1	1	1	1
16	155400010	Screw	1	1	1	1	1
17	S150225005	Screw	1	1	1	1	1
18	155320000	Pin	2	2	2	2	2
19	155300008	Link for needle bar	1	1	1	1	1
20	155300012	Oil wick pin	1	1	1	1	1
21	S150656005	O – type ring	1	1	1	1	1
22	155300014	Upper bush needle bar	1	1	1	1	1
23	B12400432	Screw	1	1	1	1	1
24	155300013	Bush	1	1	1	1	1
25	155300010	Needle connector	1	1	1	1	1
26	155300030	Screw	1	1	1	1	1
27	S150225005	Screw	1	1	1	1	1
28	155300015	Bush	1	1	1	1	1
29	155300016	Needle bar oil ervoir	1	1	1	1	1
30	S150215008	Screw	1	1	1	1	1
31	155350001	Needle bar	1	1	1	1	1
32	160320001	Needle holder	1				
	159320001	Needle holder		1	1		
	155350002	Needle holder				1	1
33	182610010	Screw	1	2	2	2	2
34	159300007	Needle	1				
	159300007	Needle		2	2		
	028280109	Needle				2	
	077200401	Needle					2
35	155300021	Screw	2	2	2	2	2
36	155300020	Set plate for oil felt	1	1	1	1	1
37	155300019	Oil felt	1	1	1	1	1
38	155300022	Oil reservoir	1	1	1	1	1

● 2000-5 (5x5)

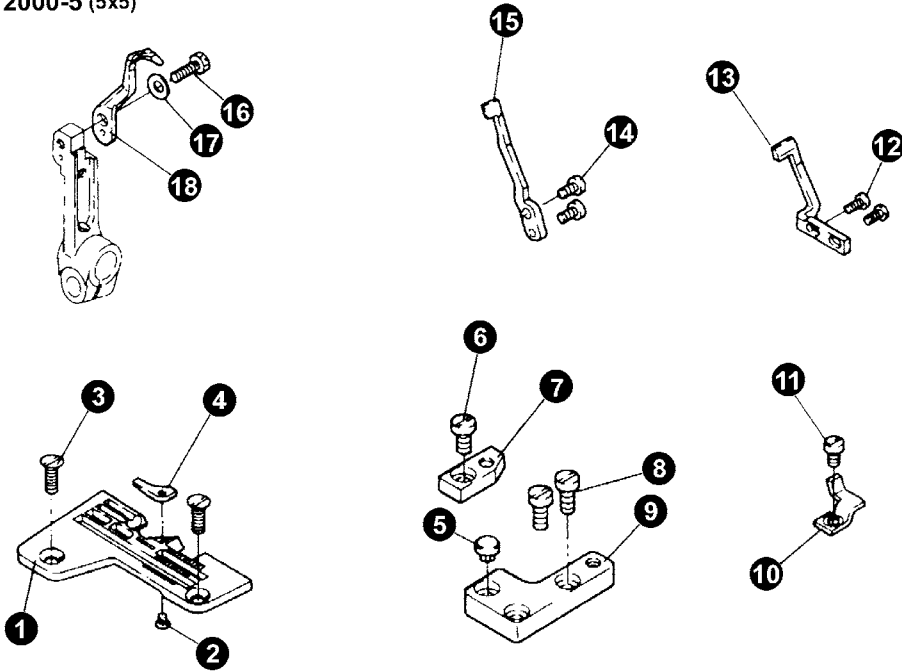

● 2000-3,-4

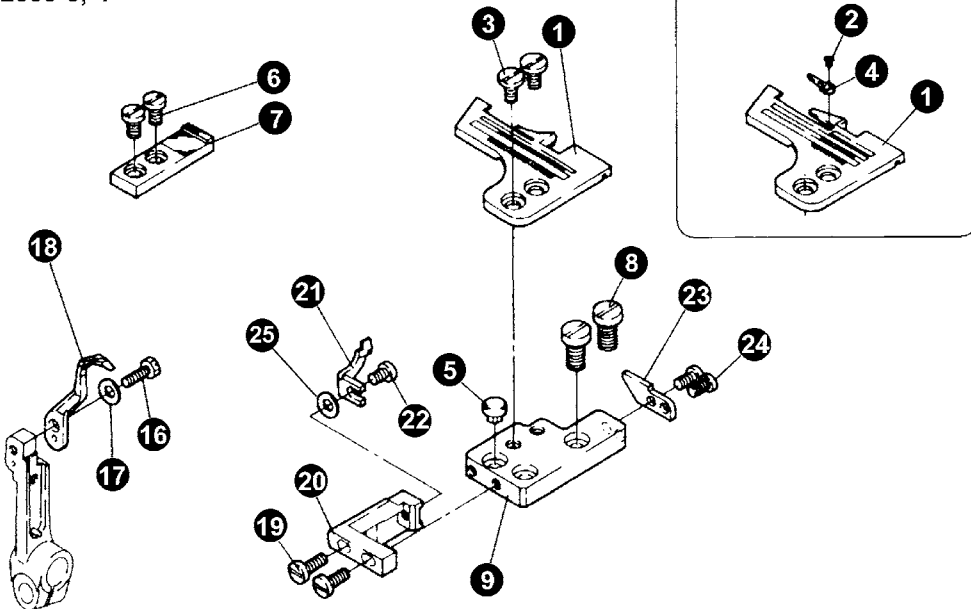

● 2000-4

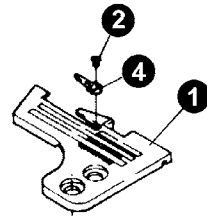

6. NEEDLE BAR DRIVE PARTS(3)

No	Ret. No.	Description	Qt			
			3	4/4H	5	5H
1	160300001	Needle plate	1			
	160300003	Needle plate	1			
	159310001	Needle plate		1		
	155340001	Needle plate			1	
	155380001	Needle plate				1
2	159310003	Screw		1		
	039230003	Screw			1	1
3	159300006	Screw	2	2		
	028200050	Screw			2	2
4	159310002	Needle plate fitting(S)		1		
	155340002	Needle plate fitting			1	
	155380002	Needle plate fitting				1
5	155100027	Rubber plug	1	1	1	1
6	B62400812	Screw	2	2		
	B62400812	Screw			1	1
7	159330000	Needle plate baracket(rear)	1	1		
	155300029	Needle plate baracket(rear)			1	1
8	B62401012	Screw	2	2		
	B62401012	Scrw			2	2
9	159300004	Needle plate bracket(front)	1	1		
	155300028	Needle plate bracket(front)			1	1
10	155300027	Chain stitch needle guard (front)			1	1
11	S150217002	Screw			1	1
12	S120202001	Screw			2	2
13	155300026	Chain stitch needle guard (rear)			1	1
14	S150217002	Screw			2	2
15	155300025	Needle guard			1	1
16	028200054	Screw	1	1	1	1
17	058600008	Washer	1	1	1	1
18	155300024	Movalbe needle guard	1	1	1	1
19	110550005	Screw	2	2		
20	159300002	Needle guard bracket	1	1		
21	159300001	Needle guard	1	1		
22	SFB0201003	Screw	1	1		
23	159300005	Needle plate guide plate	1	1		
24	SFB0201004	Screw	2	2		
25	S8A3103002	Washer	1	1		

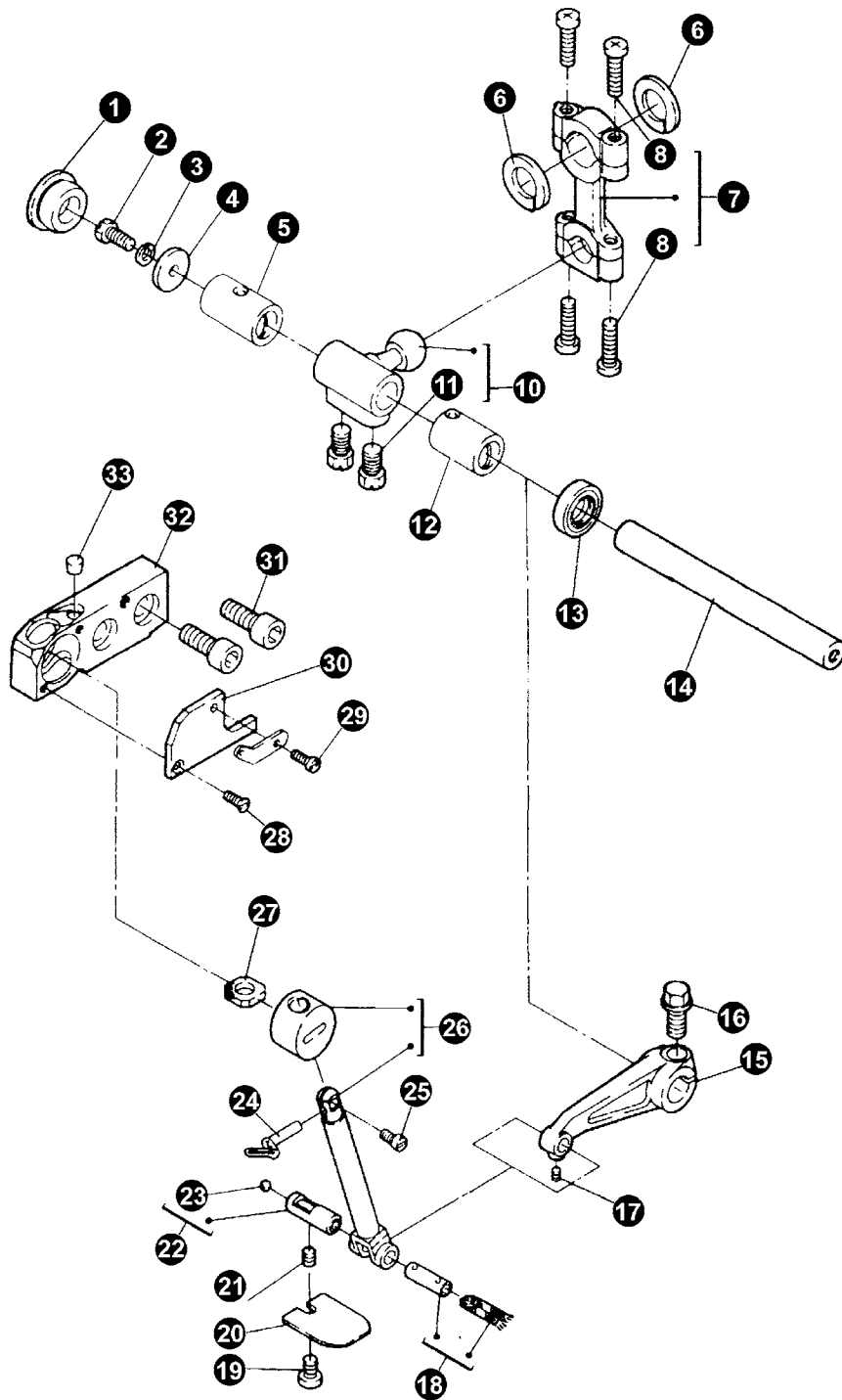

7. UPPER AND LOWER LOOPER DRIVE PART(1)

No	Ret. No.	Description	Qt				
			3	4	4H	5	5H
1	155400006	Rubber plug	1	1	1	1	1
2	S150204002	Screw	2	2	2	2	2
3	S8A3103012	Spring washer	2	2	2	2	2
4	155400005	Washer	1	1	1	1	1
5	155400004	Bush	1	1	1	1	1
6	155400001	Washer	2	2	2	2	2
7	155410000	looper ball link complete	1	1	1	1	1
8	B62401612	Screw	4	4	4	4	4
10	155420000	Upper looper ball crank complete	1	1		1	
	159400002	Upper looper ball crank complete			1		1
11	155400021	Screw	2	2	2	2	2
12	155400003	Bushing	1	1	1	1	1
13	028330001	Oil seal	1	1	1	1	1
14	155400002	Upper/lower looper shaft	1	1	1	1	1
15	155400009	Upper looper crank	1	1	1	1	1
16	155400010	Screw	1	1	1	1	1
17	S150225005	Screw	1	1	1	1	1
18	155430000	Pin complete	1	1	1	1	1
19	S150215008	Screw	1	1	1	1	1
20	155400014	Oil reservoir	1	1	1	1	1
21	B12400432	Screw	1	1	1	1	1
22	155440000	Pin complete	1	1	1	1	1
23	S8A3105006	Small ball plug	1	1	1	1	1
24	160400001	Upper looper	1				
	159400001	Upper looper		1	1		
	155400015	Upper looper				1	
	155400025	Upper looper					1
25	028100007	Screw	1	1	1	1	1
26	155400011/12	Upper looper tension shaft and guide	1	1	1	1	1
27	155400013	Oil felt	1	1	1	1	1
28	S150218001	Screw	1	1	1	1	1
29	S150217011	Screw	1	1	1	1	1
30	155400016	Over looper guide cover	1	1	1	1	1
31	S150220005	Screw	2	2	2	2	2
32	155400007	Over looper mechanism	1	1	1	1	1
33	155400008	Oil felt	1	1	1	1	1

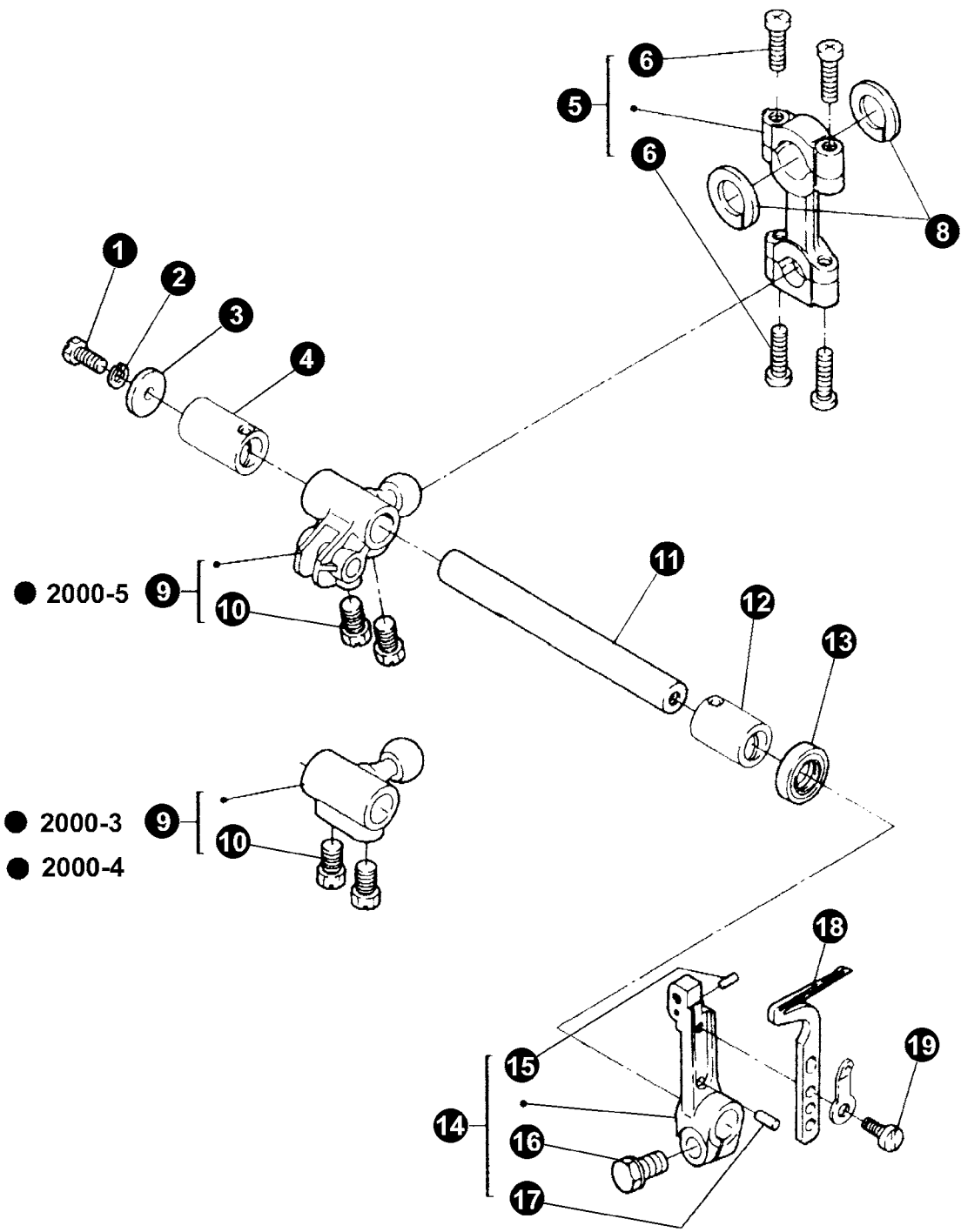

8. UPPER AND LOWER LOOPER DRIVE PART(2)

No	Ret. No.	Description	Qt			
			3	4/4H	5	5H
1	S150204002	Screw	1	1	1	1
2	S8A3103012	Spring washer	1	1	1	1
3	155400005	Washer	1	1	1	1
4	155400020	Bush	1	1	1	1
5	155410000	Looper ball link complete	1	1	1	1
6	B62401612	Screw	4	4	4	4
8	155400001	Washer	2	2	2	2
9	159400002	Lower looper ball crank		1		
	155400019	Lower looper ball crank			1	1
	155420000	Lower looper ball crank	1			
10	155400021	Screw	2	2	2	2
11	155400002	Upper/lower looper shaft	1	1	1	1
12	155400003	Bush	1	1	1	1
13	028330001	Oil seal	1	1	1	1
14	155451000	Lower looper holder complete	1	1	1	1
15	028300043	Pin	1	1	1	1
16	155400010	Screw	1	1	1	1
17	028300046	Pin	1	1	1	1
18	155450002	Lower looper	1	1	1	1
19	028100027	Screw	1	1	1	1

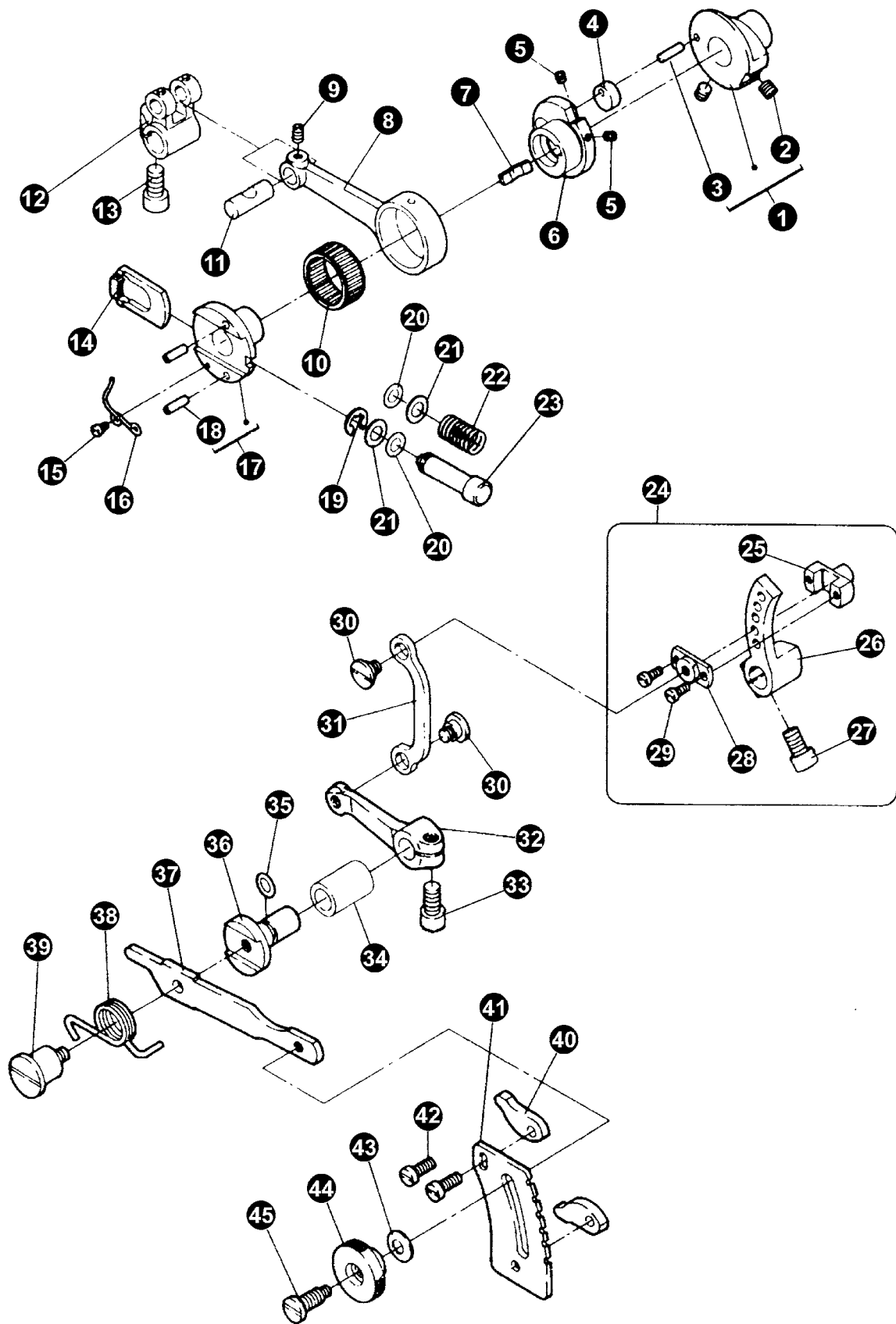

9. FEED DOG LIFT PART(1)

No	Ret. No.	Description	Qt			
			3	4/4H	5	5H
1	155530000	Feed drive cam holder complete	1	1	1	1
2	B12500532	Screw	2	2	2	2
3	028400082	Pin	1	1	1	1
4	028400080	Roller	1	1	1	1
5	S150224015	Screw	2	2	2	2
6	155500026	Feed drive cam	1	1	1	1
7	155500027	Plate spring	1	1	1	1
8	155500028	Link for feed drive	1	1	1	1
9	S150225008	Screw	1	1	1	1
10	155540000	Needle bearing	1	1	1	1
11	155300023	Pin	1	1	1	1
12	155500029	Crank for feed drive	1	1	1	1
13	155300017	Screw	1	1	1	1
14	155500030	Stitch length adjust stopper	1	1	1	1
15	155500032	Screw	1	1	1	1
16	155500031	Spring	1	1	1	1
17	155550000	Stitch length cam complete	1	1	1	1
18	S150446010	Spring pin	2	2	2	2
19	S8A3103018	Retaining ring	1	1	1	1
20	S4A0604005	O – type ring	2	2	2	2
21	155500035	Washer	2	2	2	2
22	155500034	Spring	1	1	1	1
23	155500033	Push	1	1	1	1
24	155560000	Diff. Feed crank complete	1	1	1	1
25	155560002	Differential feed dog holder	1	1	1	1
26	155560001	Diff. feed crank	1	1	1	1
27	155300017	Screw	1	1	1	1
28	155560003	Cover for differential feed dog holder	1	1	1	1
29	S150217012	Screw	2	2	2	2
30	155500037	Screw	2	2	2	2
31	155500036	Diff. Feed regulating link	1	1	1	1
32	155500038	Differential feed adjust link crank	1	1	1	1
33	155300017	Screw	1	1	1	1
34	155500040	Bush	1	1	1	1
35	S4A0604005	O – type ring	1	1	1	1
36	155500039	Diff. feed regulating shaft	1	1	1	1
37	155500041	Diff. Feed regulating	1	1	1	1
38	155500042	Spring	1	1	1	1
39	155500043	Screw	1	1	1	1
40	155500044	Stopper plate	2	2	2	2
41	155500045	Differential stitch control	1	1	1	1
42	S150215010	Screw	2	2	2	2
43	028400044	Washer	1	1	1	1
44	155500046	Nut	1	1	1	1
45	155500047	Screw	1	1	1	1

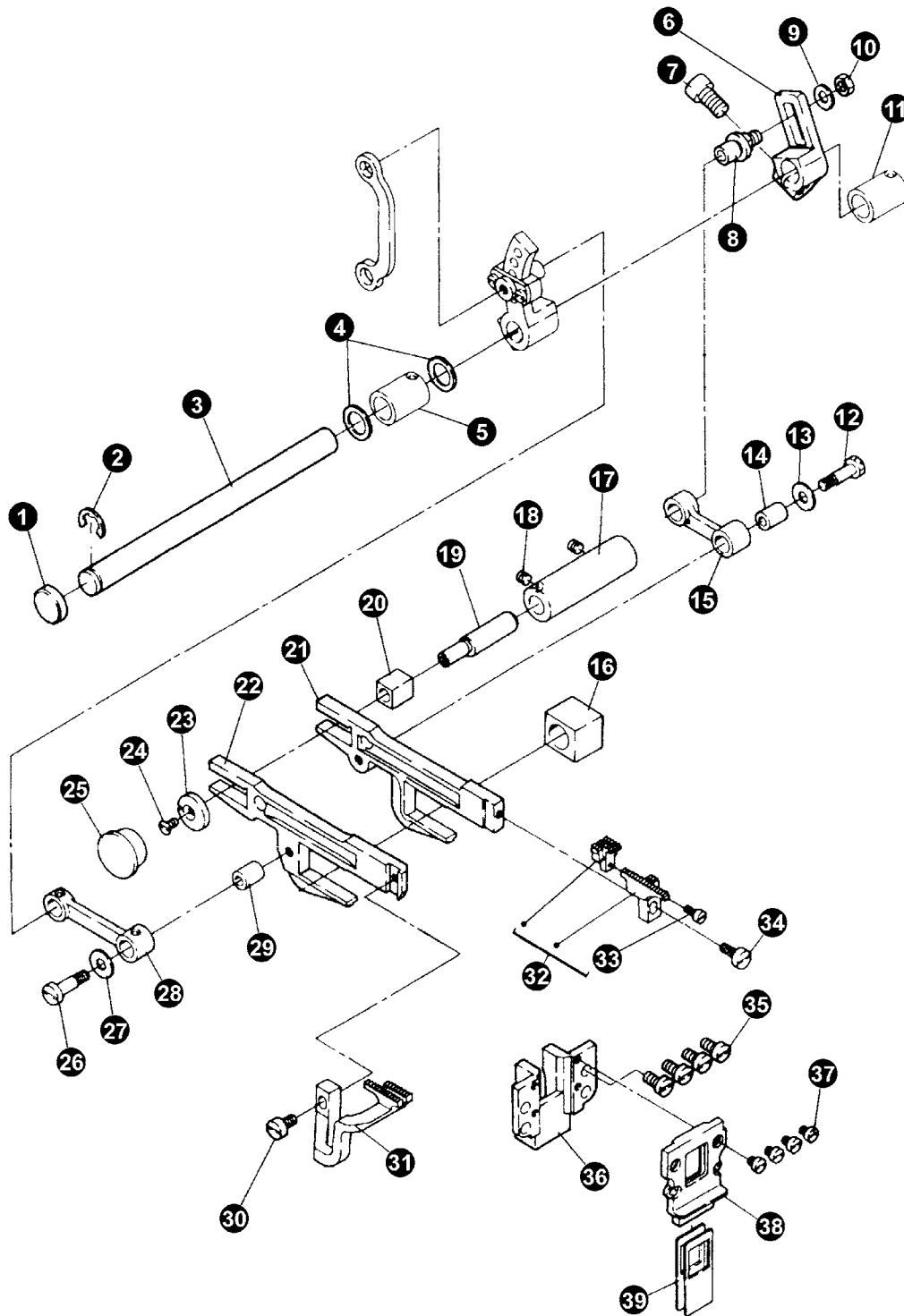

10. FEED DOG LIFT PART(2)

No	Ret. No.	Description	Qt			
			3	4/4H	5	5H
1	028310001	Oil seal	1	1	1	1
2	060410014	Retaining ring	1	1	1	1
3	155500001	Feed shaft	1	1	1	1
4	155300006	Washer	2	2	2	2
5	155500003	Left bush for feed shaft	1	1	1	1
6	155500005	Feed crank	1	1	1	1
7	155300017	Screw	1	1	1	1
8	155500006	Pin	1	1	1	1
9	155500010	Washer	1	1	1	1
10	S120503010	Nut	1	1	1	1
11	155500004	Right bush for feed shaft	1	1	1	1
12	028400023	Screw	1	1	1	1
13	155500010	Washer	1	1	1	1
14	028400021	Roller for feed dog holder link	1	1	1	1
15	155500008	Link for feed dog holder	1	1	1	1
16	155500019	Slide block for feed dog	1	1	1	1
17	155500014	Eccentric shaft bush	1	1	1	1
18	B12400432	Screw	2	2	2	2
19	028400055	Eccentric shaft	1	1	1	1
20	155500012	Slide block	1	1	1	1
21	155510001	Feed dog holder	1	1	1	1
22	155510002	Differential feed dog holder	1	1	1	1
23	028400058	Washer	1	1	1	1
24	028400059	Screw	1	1	1	1
25	155500017	Oil seal	1	1	1	1

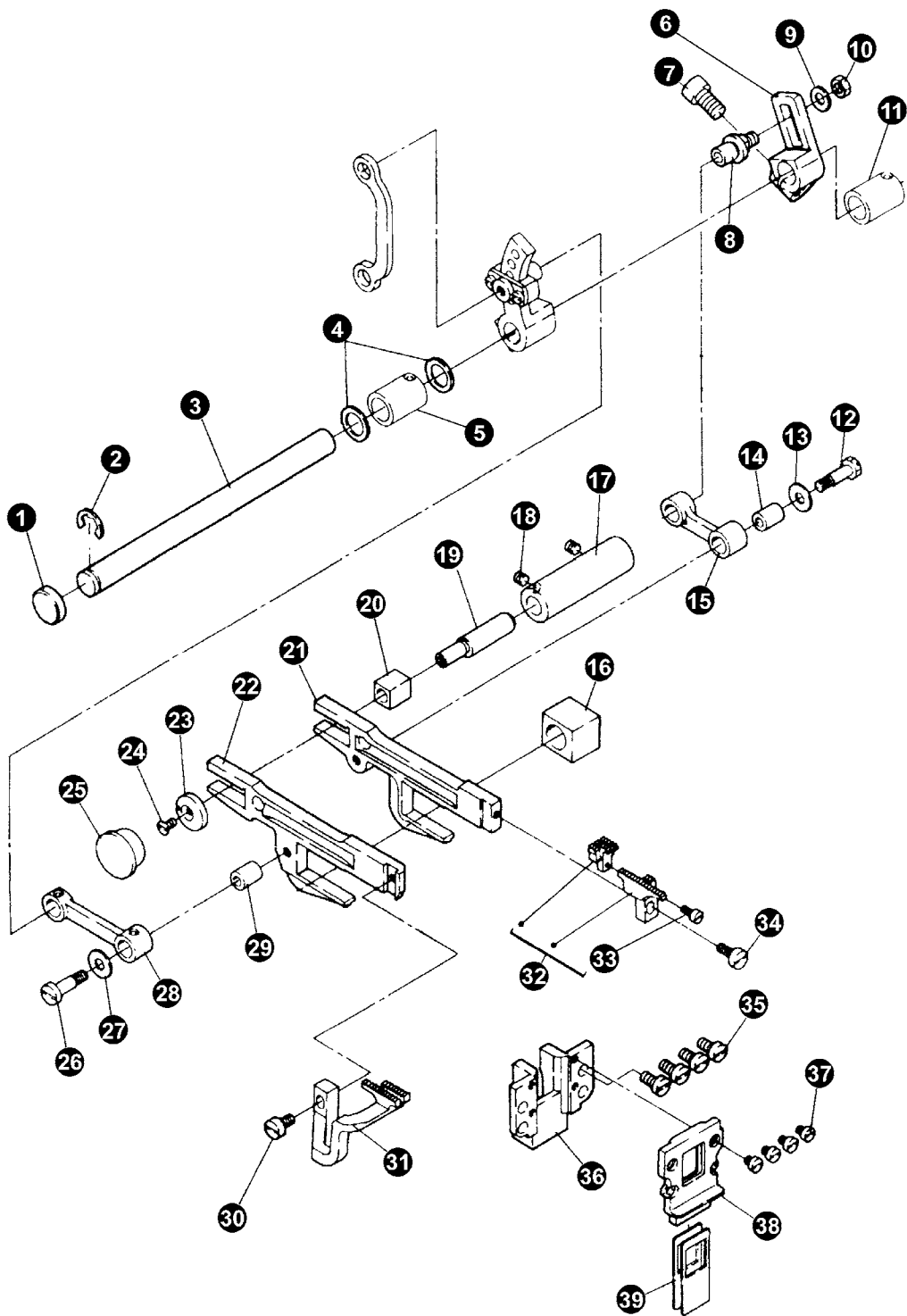

10. FEED DOG LIFT PART(2)

No	Ret. No.	Description	Qt			
			3	4/4H	5	5H
26	028400023	Screw	1	1	1	1
27	155500010	Washer	1	1	1	1
28	155500018	Link for differential feed dog holder	1	1	1	1
29	028400021	Roller for feed dog holder link	1	1	1	1
30	028200056	Screw			1	1
	028100027	Screw	1	1		
31	155500021	Differential feed dog			1	
	155500050	Differential feed dog				1
	160500001	Differential feed dog	1			
	159500001	Differential feed dog		1		
	159500001	Differential feed dog	1			
32	155580000	Main feed dog complete				1
	155580001	Main feed dog				1
	155520002	Auxible feed dog				1
32	155520000	Main feed dog complete			1	
	155520001	Main feed dog			1	
	155520002	Auxible feed dog			1	
32	159510000	Main feed dog complete		1		
	159510001	Main feed dog		1		
	159510002	Auxible feed dog		1		
32	160510000	Main feed dog complete	1			
	160510001	Mian feed dog	1			
	159510000	Main feed dog complete	1			
33	028400004	Screw	1	1	1	1
34	028100027	Screw	1	1	1	1
35	S150215001	Screw	4	4	4	4
36	155500023	Differential feed guide bracket	1	1	1	1
37	S120202007	Screw	4	4	4	4
38	155500024	Differential feed seal guide plate	1	1	1	1
39	155500025	Differential feed seal plate	2	2	2	2

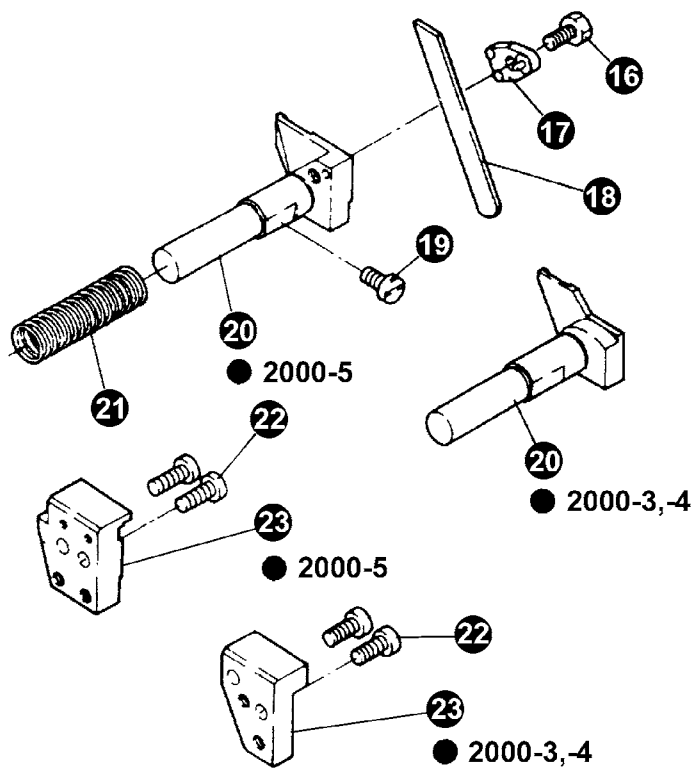
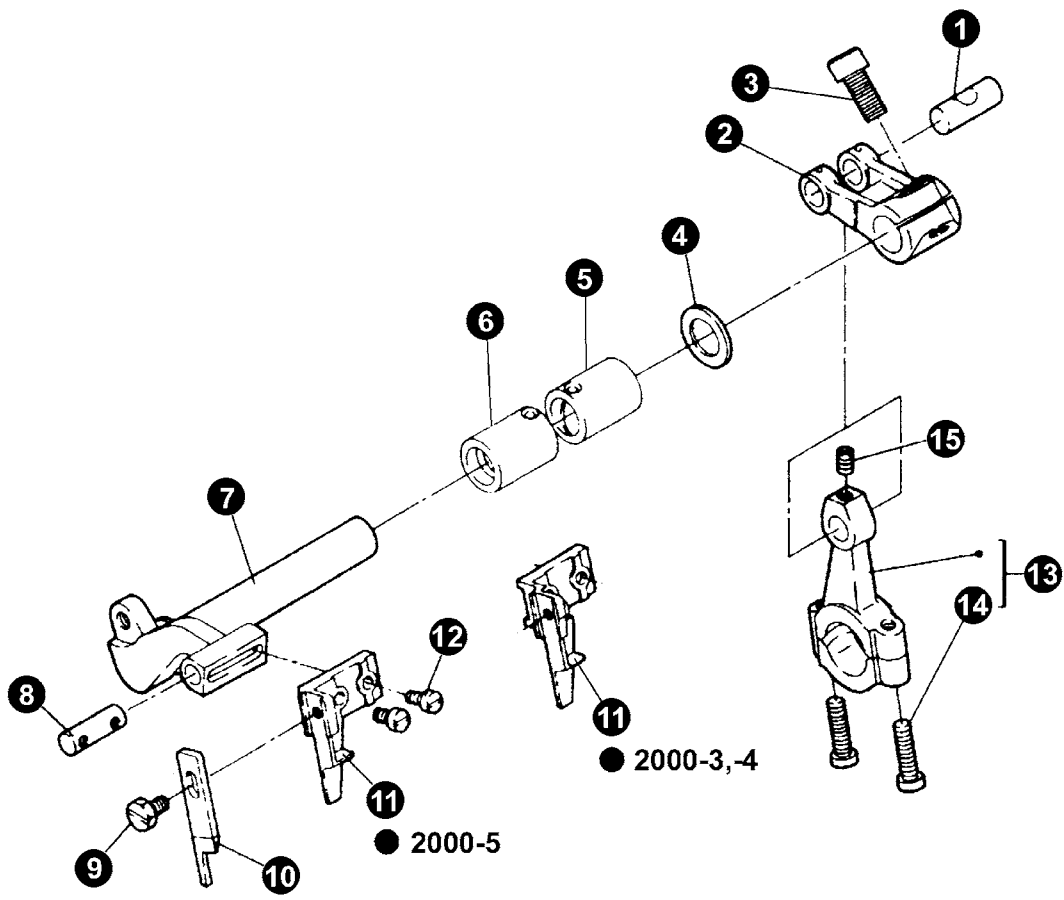

11. CUTTER DRIVE PARTS

No	Ret. No.	Description	Qt			
			3	4/4H	5	5H
1	155300023	Pin	1	1	1	1
2	155600001	Crank for upper cutter drive	1	1	1	1
3	155300017	Screw	1	1	1	1
4	155600002	Washer	1	1	1	1
5	155600005	Right bush for upper cutter bar	1	1	1	1
6	155600004	Left bush for upper cutter bar	1	1	1	1
7	155600003	Upper knife bar	1	1	1	1
8	155600006	Pin			1	1
	159600001	Pin	1	1		
9	155600013	Screw	1	1	1	1
10	155600008	Upper knife	1	1	1	1
11	159600002	Upper knife holder	1	1		
	155600007	Upper knife holder			1	1
12	B60350812	Screw	2	2	2	2
13	155610000	Link for upper knife drive complete	1	1	1	1
14	B62401612	Screw	2	2	2	2
15	S150225008	Screw	1	1	1	1
16	028300027	Screw	1	1	1	1
17	028500013	Clamp for lower cutter	1	1	1	1
18	159600004	Lower knife	1	1		
	155600011	Lower knife			1	1
19	S150215001	Screw	1	1	1	1
20	159600003	Lower knife holder	1	1		
	155600009	Lower knife holder			1	1
21	155600010	Spring	1	1	1	1
22	S150215010	Screw	2	2	2	2
23	155600012	Needle guard holder			1	1
	159600005	Needle guard holder	1	1		

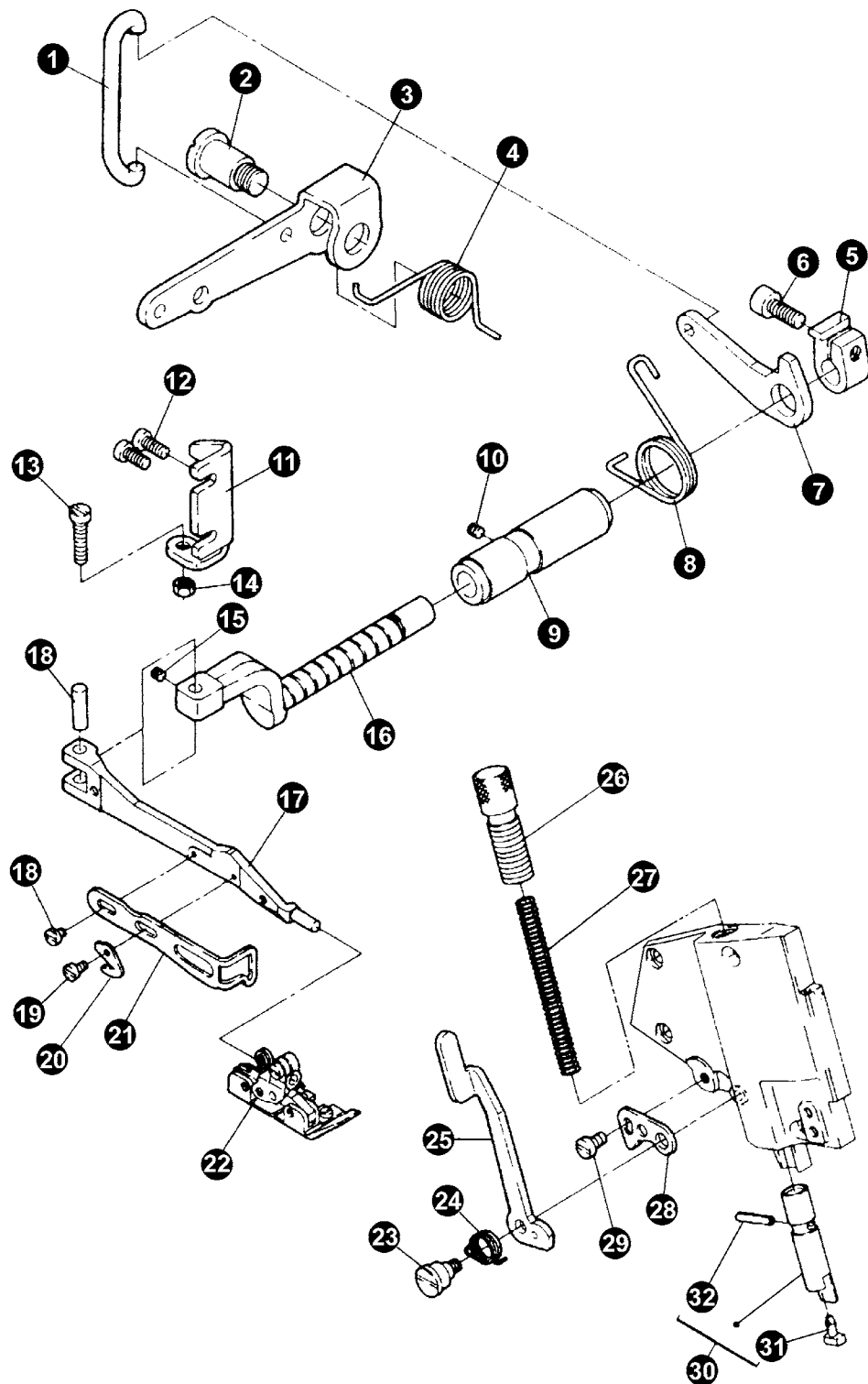

12. PRESSER FOOT LIFT PARTS(1)

No	Ret. No.	Description	Qt			
			3	4/4H	5	5H
1	155800011	Link for foot lift lever	1	1	1	1
2	155800010	Screw	1	1	1	1
3	155800008	Foot lift lever	1	1	1	1
4	155800009	Spring	1	1	1	1
5	155800007	Set collar for foot lift shaft	1	1	1	1
6	155300017	Screw	1	1	1	1
7	155800005	Lever	1	1	1	1
8	155800006	Spring	1	1	1	1
9	155800004	Bush for presser foot lift	1	1	1	1
10	B12400432	Screw	1	1	1	1
11	155800012	Stopper plate	1	1	1	1
12	S150215009	Screw	2	2	2	2
13	S150215013	Screw	1	1	1	1
14	S120503010	Nut	1	1	1	1
15	S120210015	Screw	1	1	1	1
16	155800003	Press arm shaft	1	1	1	1
17	155800001	Press arm	1	1	1	1
18	155800002	Press arm pin	1	1	1	1
	S120202004	Screw	1	1	1	1
19	S120202007	Screw	1	1	1	1
20	155800020	Knife	1	1	1	1
21	159700001	Finger guard	1	1		
	155800019	Finger guard			1	1
22	160710000	Presser foot complete	1			
	160730000	Presser foot complete	1			
	159710000	Presser foot complete		1		
	039720000	Presser foot complete			1	
	77T7 - 001A	Presser foot complete				1
23	155800018	Screw	1	1	1	1
24	155800017	Spring	1	1	1	1
25	155800016	Press bar lifter	1	1	1	1
26	155800013	Screw	1	1	1	1
27	155800014	Spring	1	1	1	1
28	155800015	Press arm stopper	1	1	1	1
29	S150215008	Screw	1	1	1	1
30	155810000	Presser bar complete	1	1	1	1
31	155810002	Cushion	1	1	1	1
32	S150446011	Spring pin	1	1	1	1

● 2000-5 (5x5)

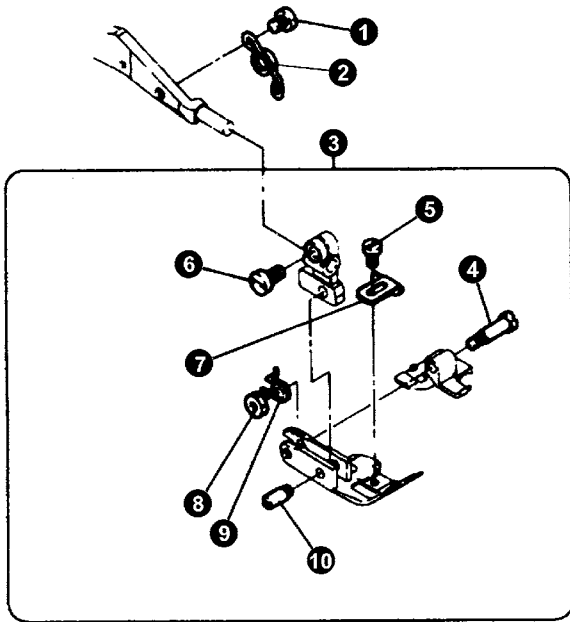

● 2000-5H

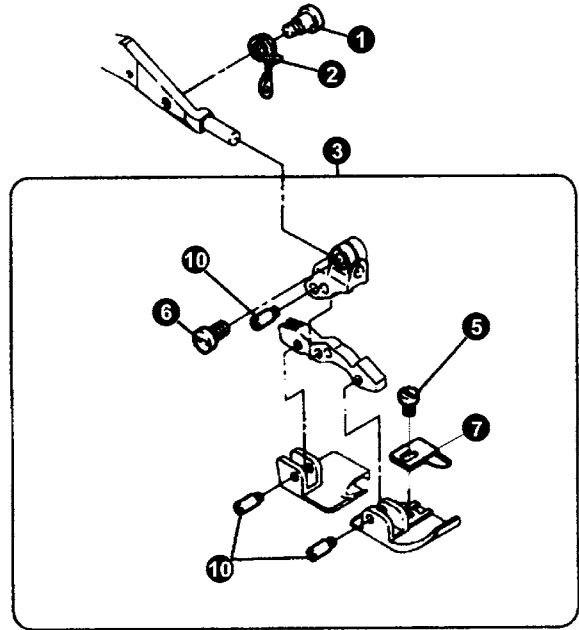

● 2000-3,-4

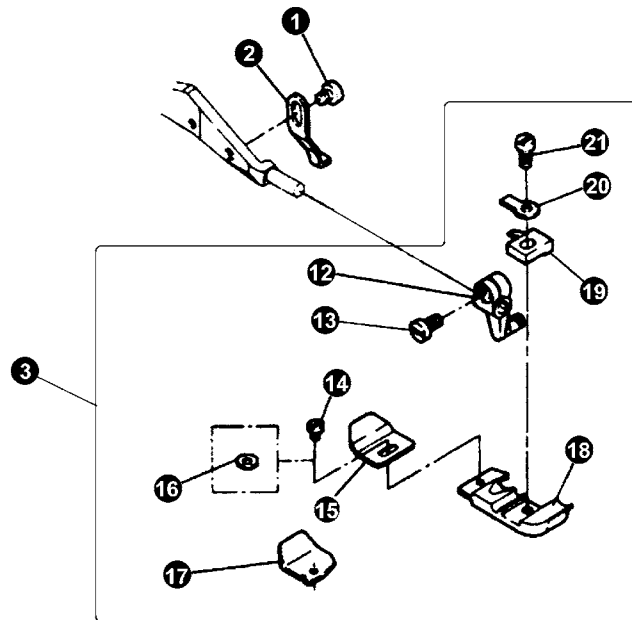

13. PRESSER FOOT LIFT PARTS(2)

No	Ret. No.	Description	Qt			
			3	4/4H	5	5H
1	S120202004	Screw			1	
2	155800021	Spring			1	
3	039720000	Presser foot complete			1	
	39T7 - 003B2	Main presser foot			1	
	39T7 - 003B3	Auxible presser foot			1	
	39T7 - 003B1	Bracket for presser foot			1	
4	39T7 - 001A3	Screw			1	
5	39T7 - 001A6	Screw			1	
6	28T1 - 007	Screw			1	
7	39T7 - 001A5	Fabric guard			1	
8	39T7 - 001A4	Screw			1	
9	39T7 - 001A10	Spring			1	
10	77T7 - 001A4	Pin			1	
1	155A20006	Screw				1
2	155800025	Spring				1
3	77T7 - 001A	Presser foot complete				1
	77T7 - 001A1	Main presser foot				1
	77T7 - 001A2	Aauxible presser foot				1
	77T7 - 001A3	Bracket for presser foot				1
	77T7 - 001A5	Link for presser foot				1
5	6A2 - 14	Screw				1
6	28T1 - 007	Screw				1
7	77T7 - 001A6	Fabric guard				1
10	77T7 - 001A4	Pin				3
1	S120202004	Screw	1	1		
2	159700002	Stopper	1	1		
3	159710000	Presser foot complete		1		
12	159710007	Bracket for presser foot	1	1		
13	028100007	Screw	1	1		
14	39T7 - 001A6	Screw	1	1		
15	28T6 - 019A1	Presser foot fitting piece	1			
16	GB97 - 76	Washer		1		
17	159710002	Presser foot fitting piece		1		
18	159710001	Main presser foot		1		
19	159710006	Guide		1		
20	159710005	Set presser for presser foot	1	1		
21	28T1 - 041	Screw	1	1		
3	160710000	Presser foot complete	1			
	160730000	Presser foot complete	1			

● 2000-5

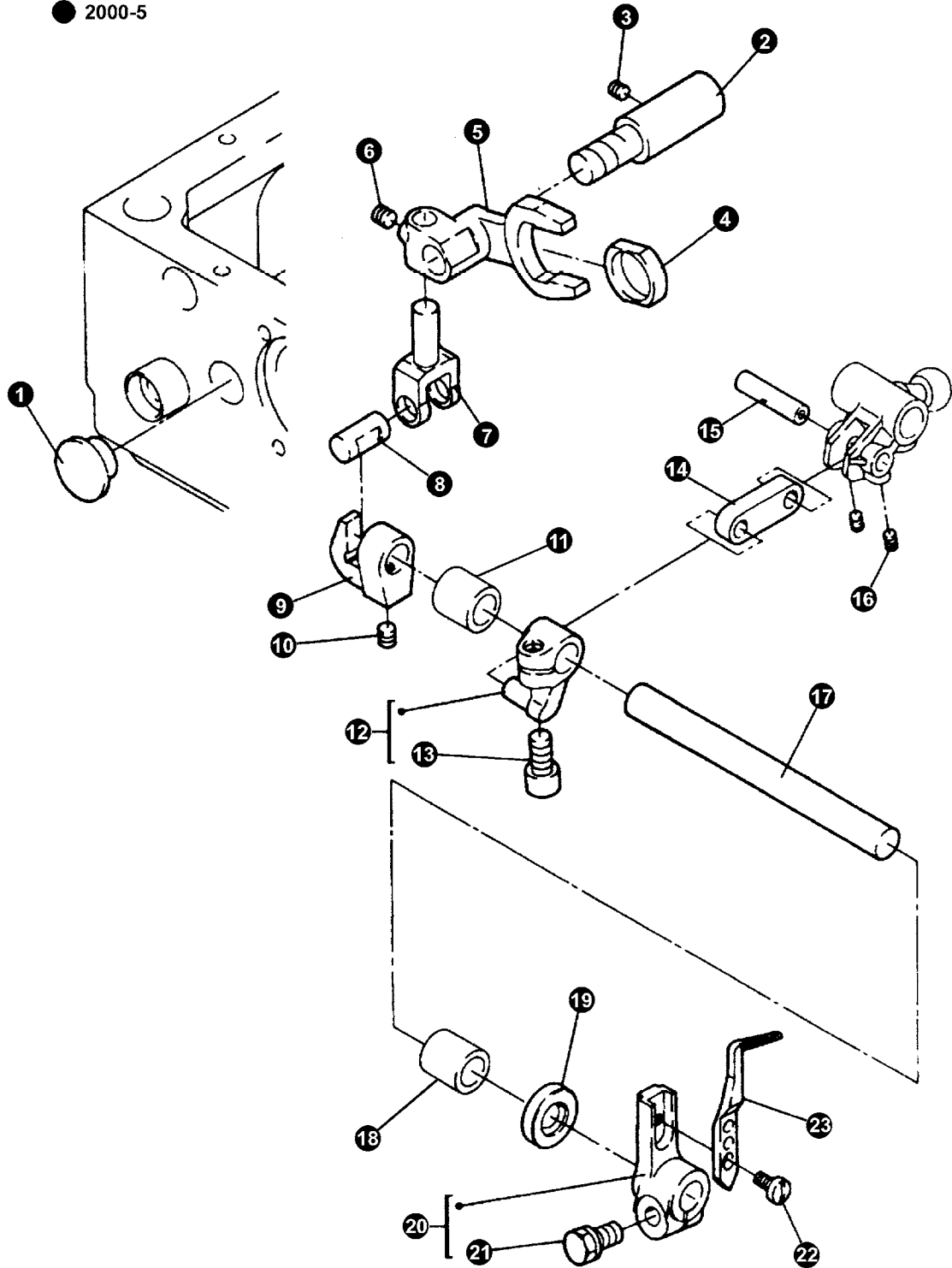

14. FRONT LOOPER PARTS(1)

No	Ret. No.	Description	Qt			
			3	4/4H	5	5H
1	155500017	Rubber cap			1	1
2	155700003	Pin shaft			1	1
3	B12500532	Screw			1	1
4	155700002	Sliding bush			1	1
5	155700001	Fork			1	1
6	B12500532	Screw			1	1
7	155700004	Connector			1	1
8	155700005	Pin			1	1
9	155700006	Slide block holder			1	1
10	B12500532	Screw			1	1
11	155700008	Bush			1	1
12	155700010	Crank for front looper			1	1
13	155300017	Screw			1	1
14	039400009	Link for front looper			1	1
15	039400010	Pin			1	1
16	S150237030	Screw			2	2
17	155700007	Shaft for looper drive			1	1
18	155700008	Bush			1	1
19	028330001	Oil seal			1	1
20	155710000	Front looper holder complete			1	
	155730000	Front looper holder complete				1
21	155400010	Screw			1	1
22	006300018	Screw			1	1
23	155710002	Front looper			1	
	155730001	Front looper				1

● 2000-5

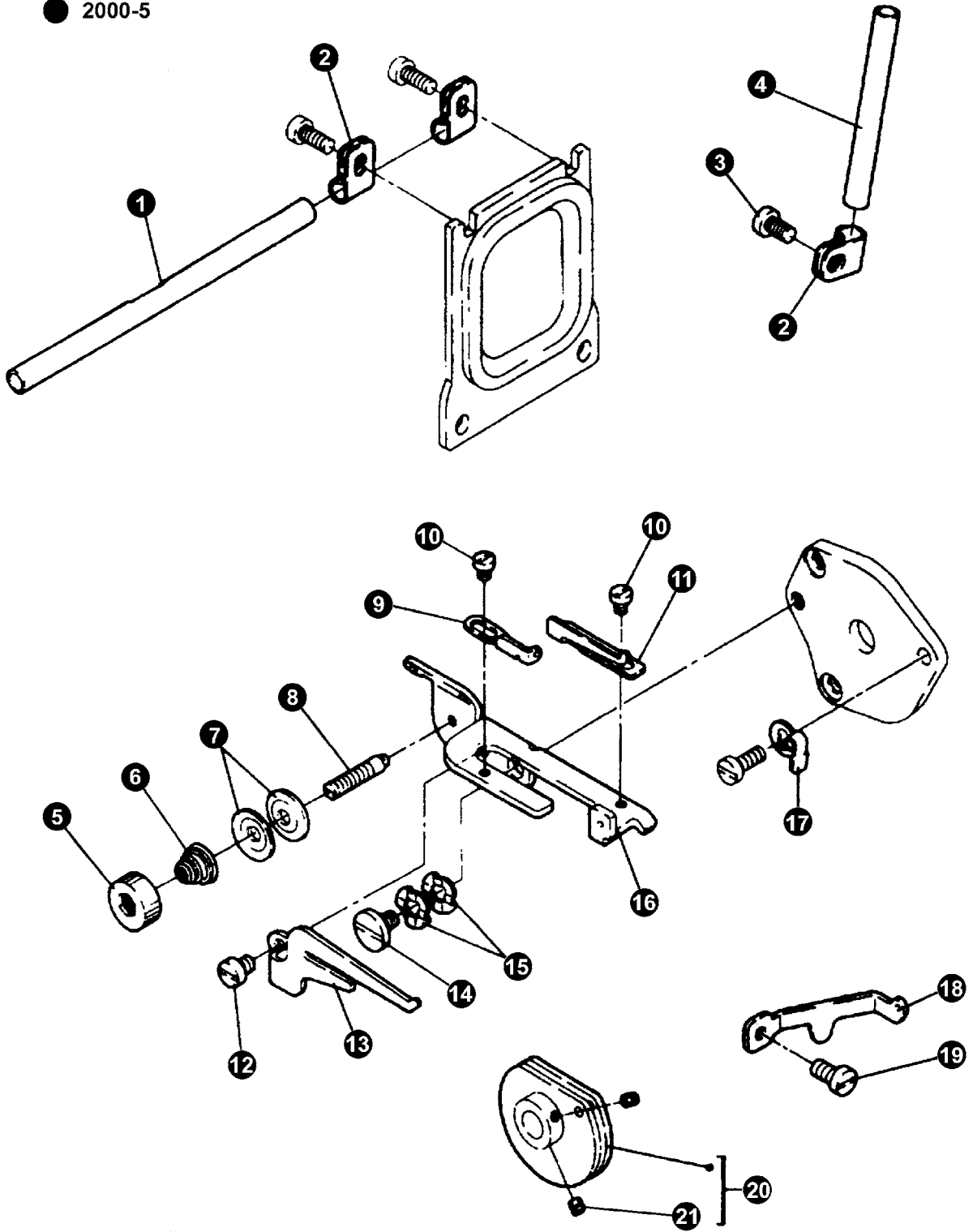

15. FRONT LOOPER PARTS(2)

No	Ret. No.	Description	Qt			
			3	4/4H	5	5H
1	039400037	Long thread pipe			1	1
2	116250002	Tube clamp			3	3
3	S150215001	Screw			1	1
4	155A00011	Short thread pipe			1	1
5	155A41000	Nut			1	1
6	039400042	Spring			1	1
7	039400041	Thread guide disc			2	2
8	155A40004	Screw			1	1
9	155A40003	Left thread guide			1	1
10	S150217009	Screw			2	2
11	155A40002	Right thread guide			1	1
12	S150215007	Screw			1	1
13	155A00009	Thread guide plate			1	1
14	155100024	Screw			1	1
15	155100025	Washer			2	2
16	155A40001	Lower thread guide bracket			1	1
17	155A00010	Spring			1	1
18	155A00008	Thread guide plate			1	1
19	S150215001	Screw			1	1
20	039410N	Thread takeup cam complete			1	1
21	182610010	Screw			2	2

● 2000-5

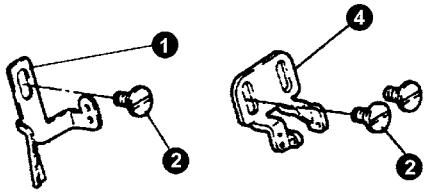

● 2000-3,-4

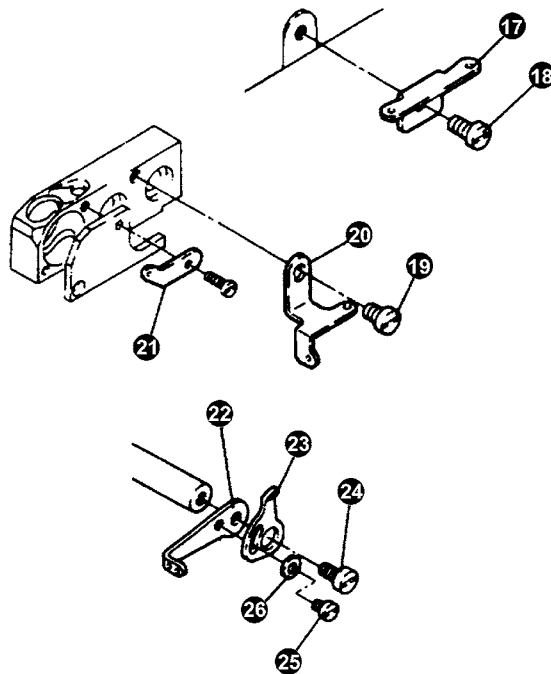
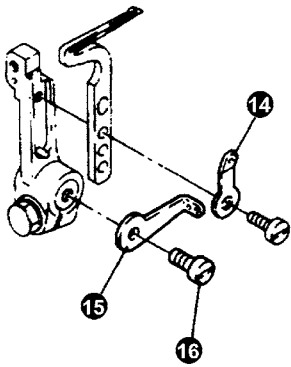
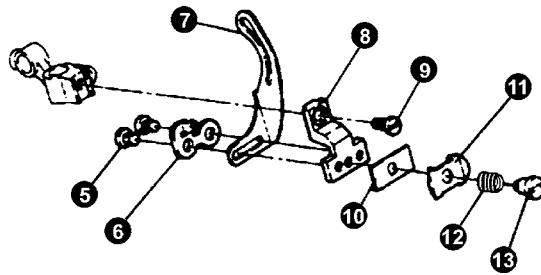
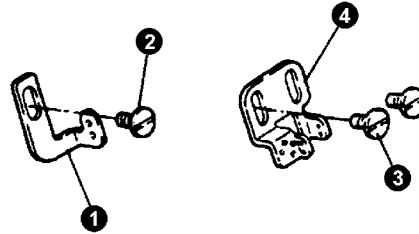

16. THREAD EYELETS (1)

No	Ret. No.	Description	Qt			
			3	4/4H	5	5H
1	159900002	Needle thread guide plate	1	1		
	155A00002	Needle thread guide plate			1	1
2	155100034	Screw	3	3	3	3
4	159900001	Thread guide plate for thread takeup plate	1	1		
	155A00001	Thread guide plate for thread takeup plate			1	1
	155A20000	Thread takeup lever complete			1	1
	159910000	Thread takeup lever complete	1	1		
5	S150217008	Screw	2	2	2	2
6	155A20007	Thread guide			1	1
7	155A20002	Thread takeup lever	1	1	1	1
8	155A20001	Thread takeup lever bracket	1	1	1	1
9	S120203019	Screw	1	1	1	1
10	155A20004	Bracket	1	1	1	1
11	155A20003	Thread retaining plate			1	1
	159910001	Thread retaining plate	1	1		
12	155A20005	Spring	1	1	1	1
13	155A20006	Screw	1	1	1	1
14	155450003	Thread guide	1	1	1	1
15	155A00003	Thread guide plate	1	1	1	1
16	S150215008	Screw	1	1	1	1
17	155A00004	Thread guide	1	1	1	1
18	S150215001	Screw	1	1	1	1
19	S150215008	Screw	2	2	2	2
20	155A00005	Thread guide plate	1	1	1	1
21	155400018	Thread guide	1	1	1	1
22	155A00006	Upper looper thread takeup (big)	1	1	1	1
23	155A00007	Upper looper thread takeup (small)	1	1	1	1
24	S150215001	Screw	1	1	1	1
25	S120202004	Screw	1	1	1	1
26	S8A3103003	Washer	1	1	1	1
			1	1	1	1

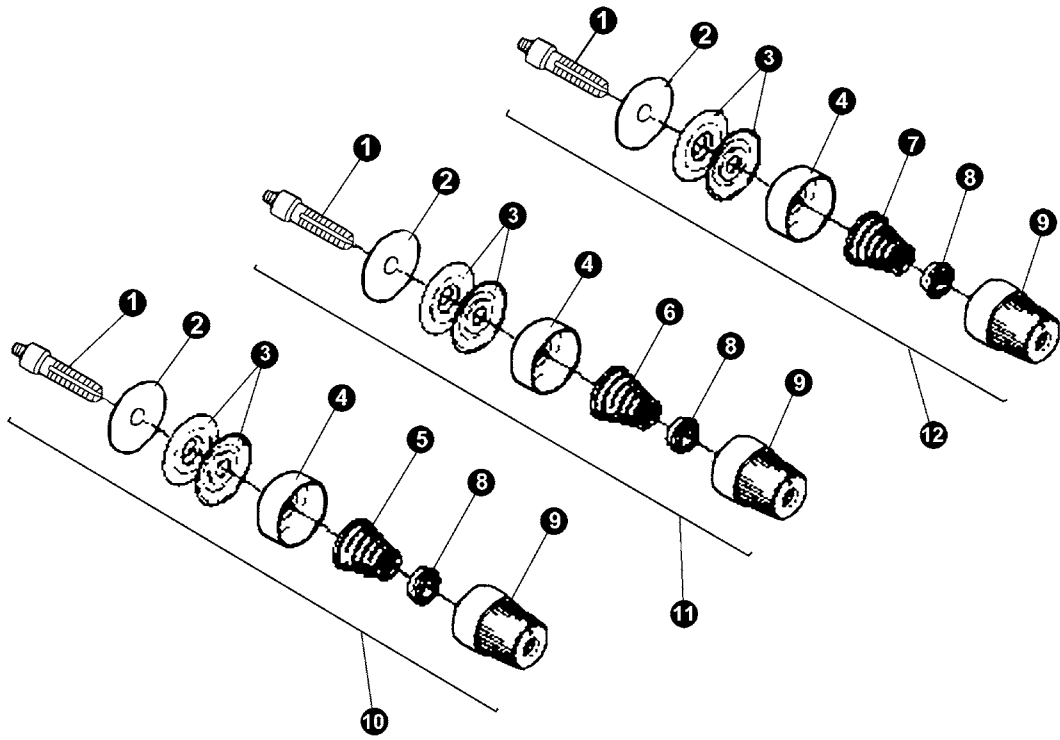

2000 - 3

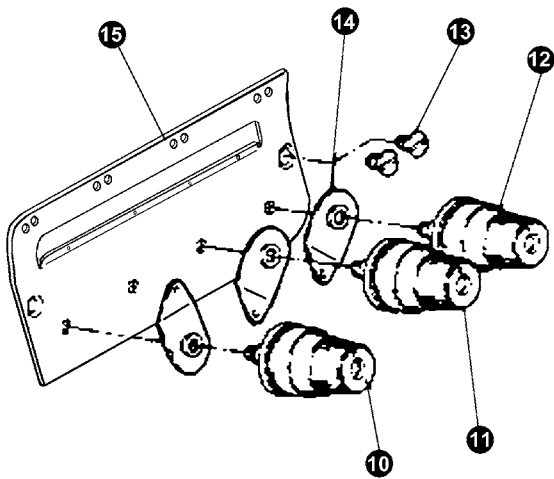

2000 - 4, 2000 - 5

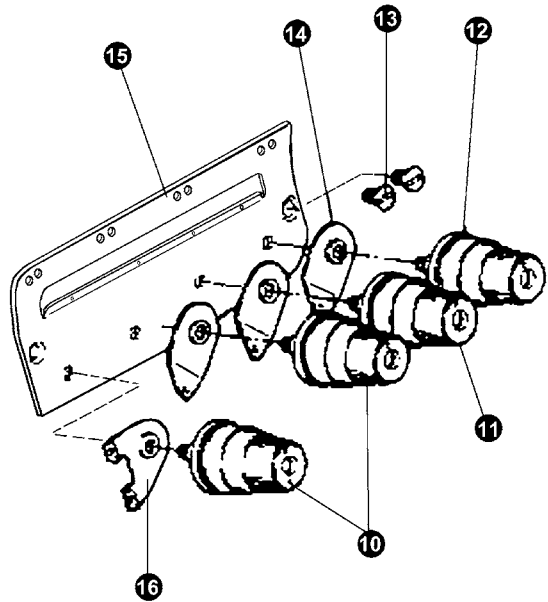

17. THREAD EYELETS(2)

No	Ret. No.	Description	Qt			
			3	4/4H	5	5H
1	155A10003	Post	3	4	4	4
2	28T2 – 060H7	Felt	3	4	4	4
3	22T1 – 012F5	Tension disc.	6	8	8	8
4	155A10008	Cup	3	4	4	4
5	155A10005	Tension spring	1	2	2	2
6	155A10004	Tension spring (upper looper)	1	1	1	1
7	155A10006	Tension spring (lower looper)	1	1	1	1
8	155A10007	Spring bushing	3	4	4	4
9	155A10009	Post nut	3	4	4	4
10		Tension nut complete	1	2	2	2
11		Tension nut complete (upper looper)	1	1	1	1
12		Tension nut complete (lower looper)	1	1	1	1
13	116400008	Screw	2	2	2	2
14	28T2 – 060H8	Tension guide plate	3	3	3	3
15	155A10000	Thread guide plate complete		1	1	1
	160910000	Thread guide plate complete	1			
16	155A10002	Thread guide plate		1	1	1

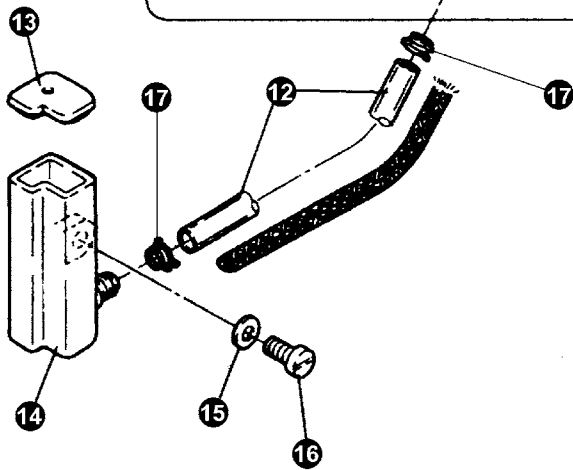
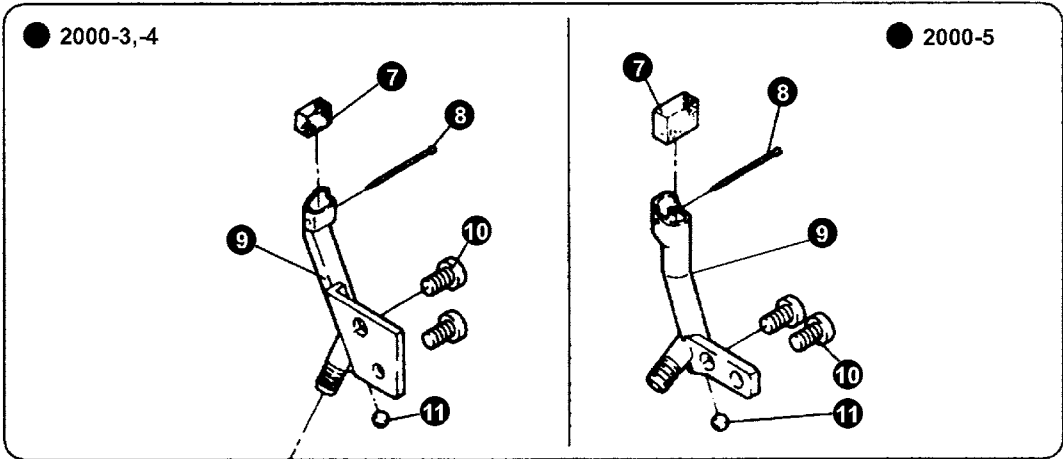
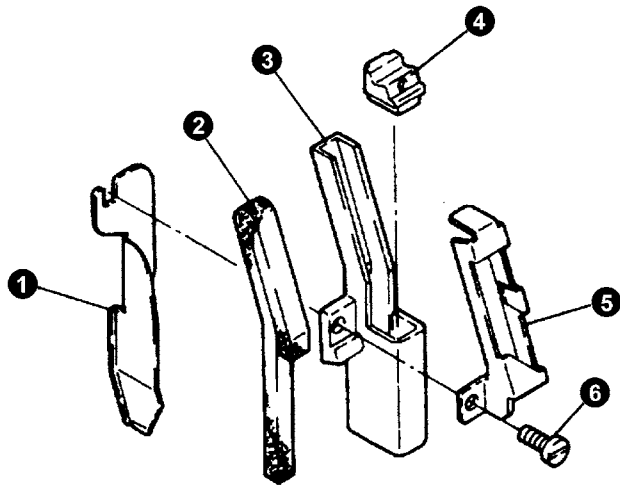

18. LUBRICATING PARTS(1)

No	Ret. No.	Description	Qt			
			3	4/4H	5	5H
1	155900019	Oil guide	1	1	1	1
2	155920003	Oil felt	1	1	1	1
3	155920001	Upper silicone oil reservoir	1	1	1	1
4	155920002	Cover for upper silicone oil reservoir	1	1	1	1
5	155900018	Thread guide	1	1	1	1
6	S150215009	Screw	1	1	1	1
7	155930002	Felt			1	1
	155930003	Felt			1	1
	159810002	Felt	1	1		
8		Pin	1	1	1	1
9	159810001	Needle cooler	1	1		
	155930001	Needle cooler			1	1
10	S150215001	Screw	2	2	2	2
11	S8A3105006	Ball plug	1	1	1	1
12	155900020	Oil tube	1	1	1	1
13	155900023	Cover for upper silicone oil reservoir	1	1	1	1
14	155900022	Cover for upper silicone oil reservoir	1	1	1	1
15	S8A3103003	Washer	1	1	1	1
16	S150215009	Screw	1	1	1	1
17	028700011	Pipe clamp	2	2	2	2

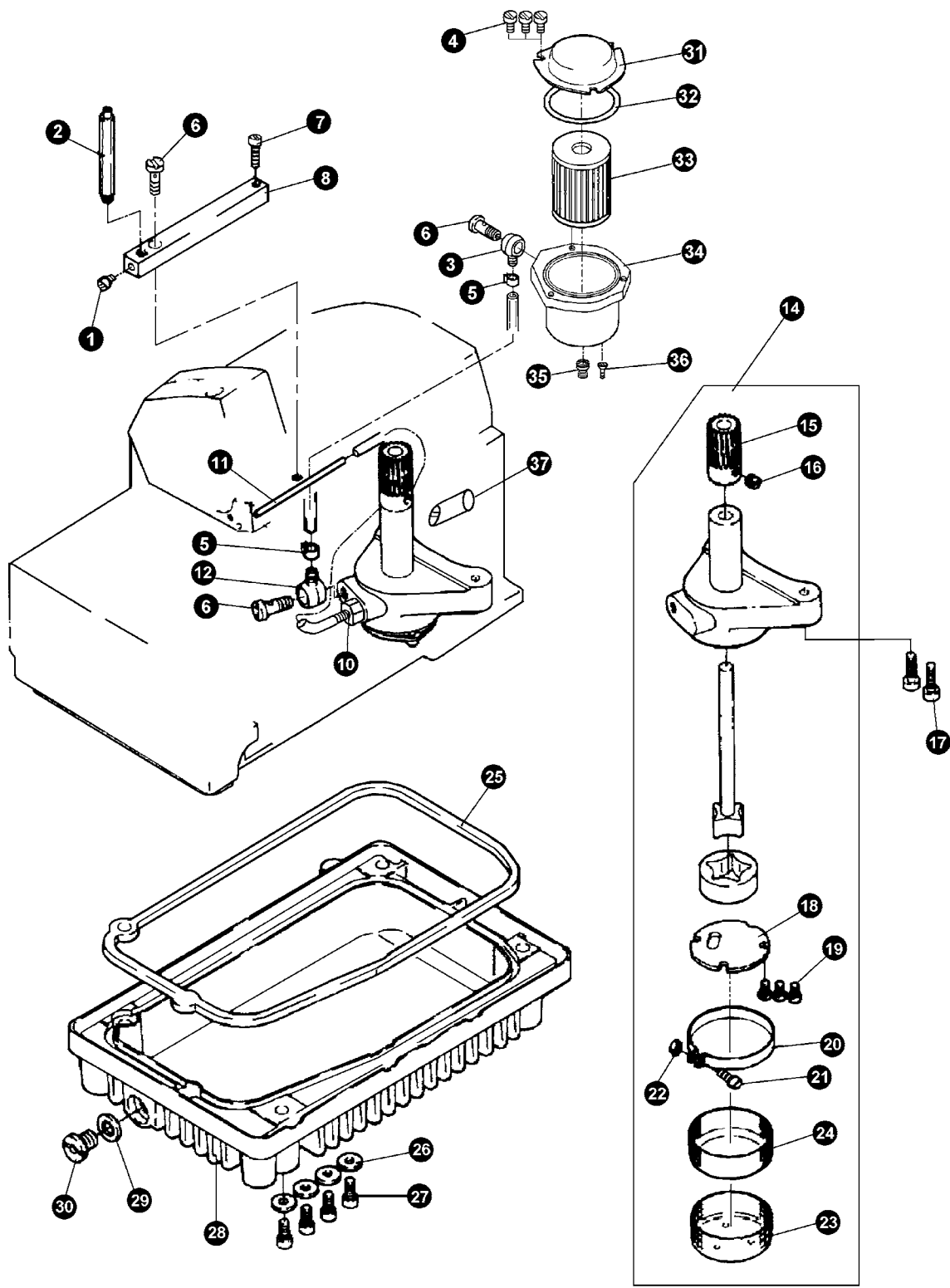

19. LUBRICATING PARTS(2)

No.	Ret. No.	Description	Qt			
			3	4/4H	5	5H
1	S150215007	Screw	1	1	1	1
2	155900007	Oil pipe for oil gauhe window	1	1	1	1
3	028700010	Oil splash connector	2	2	2	2
4	S150237007	Screw	3	3	3	3
5	028700011	Oil splash connecto clamp	2	2	2	2
6	155900005	Screw	3	3	3	3
7	S150215005	Screw	1	1	1	1
8	155900006	Oil distributor	1	1	1	1
10	155900010	Oil return pipe connector	1	1	1	1
11	155900008	Bronze oil pipe	1	1	1	1
14	155940000	Pump complete	1	1	1	1
15	155910001	Worm wheel	1	1	1	1
16	B12500532	Screw	1	1	1	1
17	S150220003	Screw	2	2	2	2
18	155940002	Cover for oil pump	1	1	1	1
19	S150217010	Screw	3	3	3	3
20	155910006	Oil filter flange	1	1	1	1
21	S150217012	Screw	1	1	1	1
22	S150559001	Screw	1	1	1	1
23	155910004	Oil filter	1	1	1	1
24	155910005	Oil filter	1	1	1	1
25	155900013	Packing	1	1	1	1
26	155900017	Washer	4	4	4	4
27	S150220015	Screw	4	4	4	4
28	155900012	Oil reservoir	1	1	1	1
29	28T7 - 025H	Packing	1	1	1	1
30	028700026	Screw	1	1	1	1
31	155900031	The cover of oil basin	1	1	1	1
32	155900032	Rubber ring	1	1	1	1
33	028770001	Filter	1	1	1	1
34	155900030	Oil basin	1	1	1	1
35	155900033	Oil storage connector	1	1	1	1
36	S150218015	Screw	1	1	1	1
37	155900027	Oil level gauge	1	1	1	1

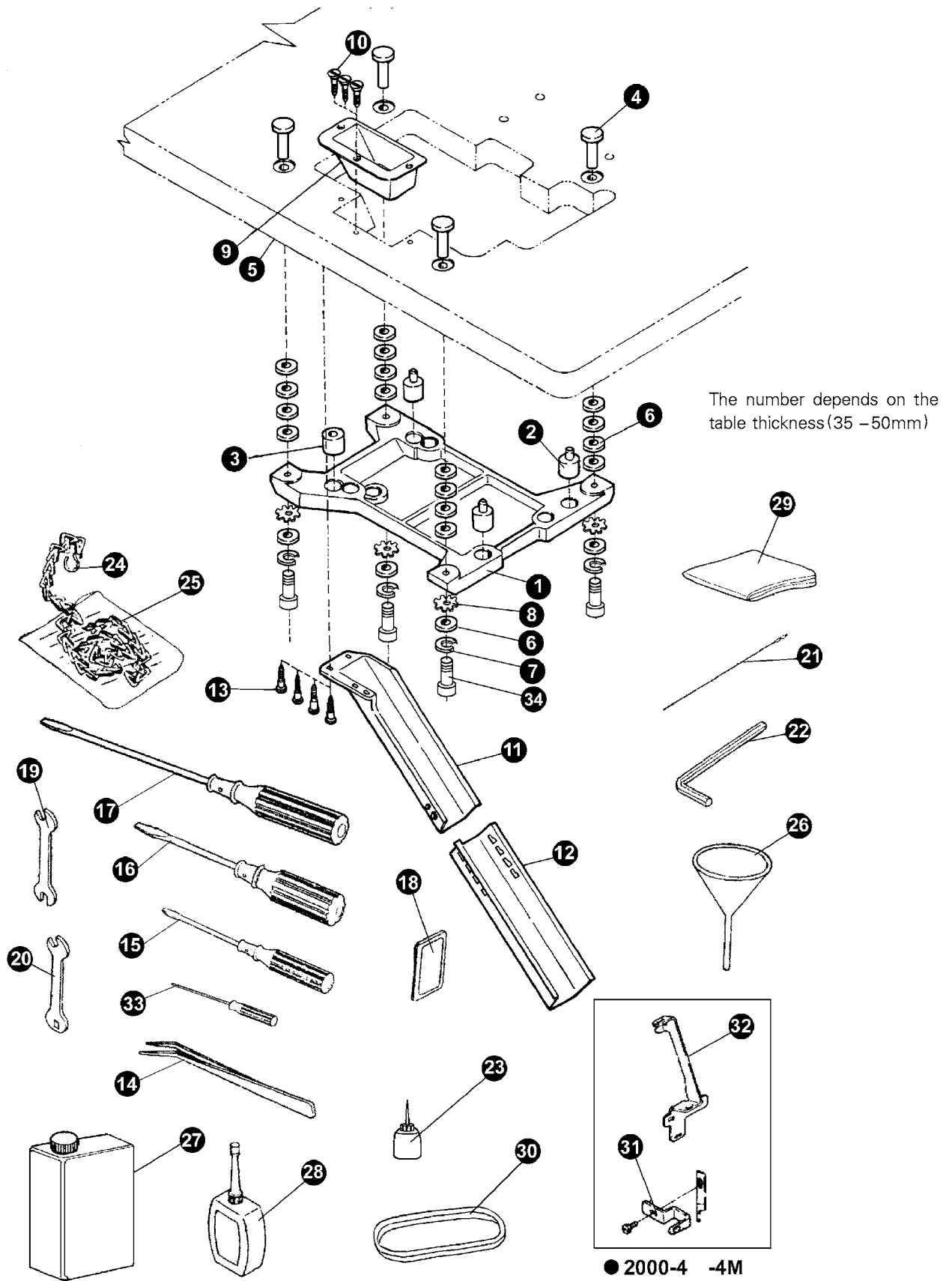

20. ACCESSORIES

No	Ret. No.	Description	Qt			
			3	4/4H	5	5H
1	28T8 – 001	Machine rest board	1	1	1	1
2	28T8 – 004A	Rubber cushion	3	3	3	3
3	28T8 – 005	Rubber cushion	1	1	1	1
4	28T8 – 002	Bolt	4	4	4	4
5	155F00001	Table	1	1	1	1
6	110F10008	Rubber cushion	20	20	20	20
7	S150630001	Washer	4	4	4	4
8	S150671001	Washer	4	4	4	4
9	28T8 – 006	Wastes chute mouth	1	1	1	1
10	GB100 – 76	Screw	3	3	3	3
11	28T8 – 007	Wastes chute (upper)	1	1	1	1
12	28T8 – 008	Wastes chute (lower)	1	1	1	1
13	GB99 – 76	screw	4	4	4	4
14	W050103006	Tweezer	1	1	1	1
15	W050102051	Screwdriver (S)	1	1	1	1
17	W050102050	Screwdriver (B)	1	1	1	1
18	159300007	Needle DC × 27	1	1	1	1
19	W050102030	Double open – end wrench (6 × 10)	1	1	1	1
20	39T10 – 005	Double open – end			1	1
21	39T10 – 001	Threading wire			1	1
22	W050102038	Hey key6	1	1	1	1
	W050102037	Hex key5	1	1	1	1
	W050102035	Hex key3	1	1	1	1
	W050102040	Hex key2. 5	1	1	1	1
	W050102034	Hex key2	1	1	1	1
23	W050202005	Silicon oil pot	1	1	1	1
25	W050103011	Chain complete	50	50	50	50
26		Funnel	1	1	1	1
27	155F00002	Oil can	1	1	1	1
28	22T9 – 001	Oil pot	1	1	1	1
29	W060302035	Vinyl cover (GB1171 – 74)	1	1	1	1
30	GB1171 – 74	Belt	1	1	1	1
31	159F00001	Tape guide holder (upper)		1		
32	159F00002	Tape guide holder (lower)		1		
33	110F00005	Hndled hex driver	1	1	1	1
34	S150220027	Screw	1	1	1	1

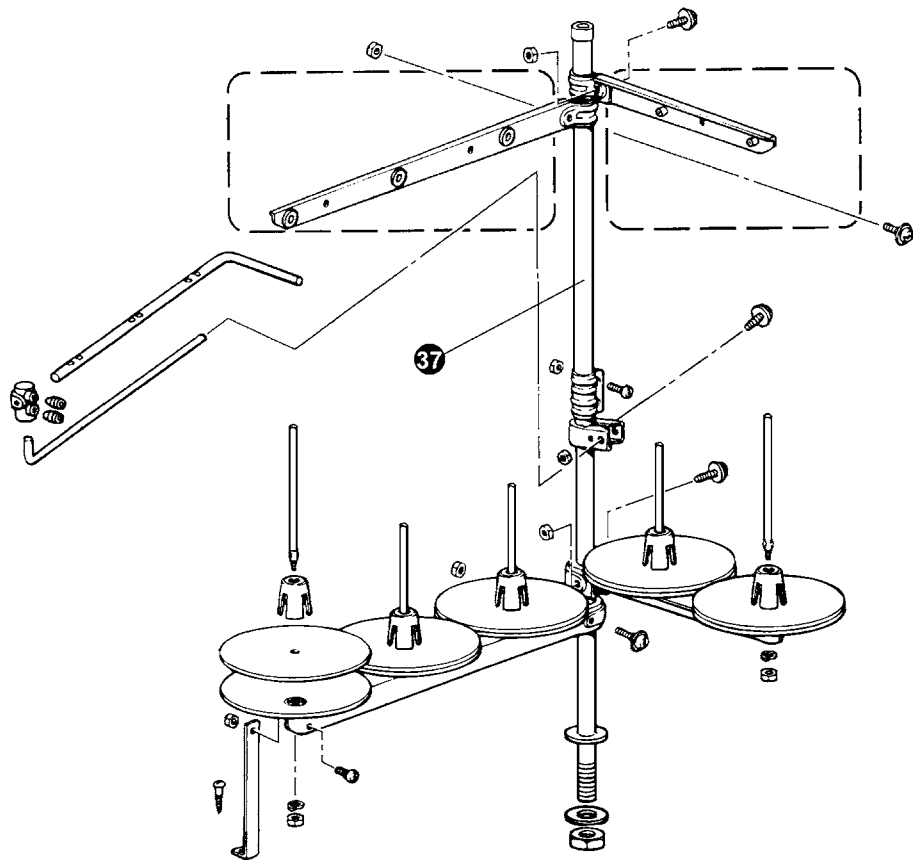
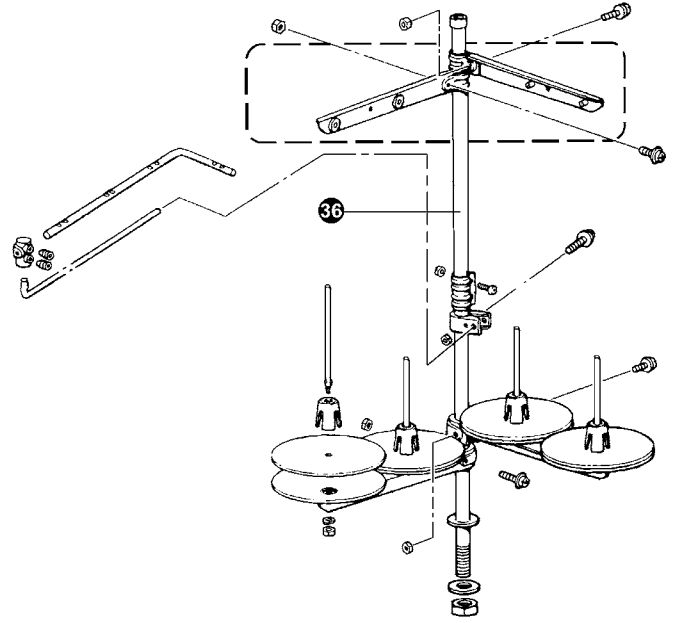
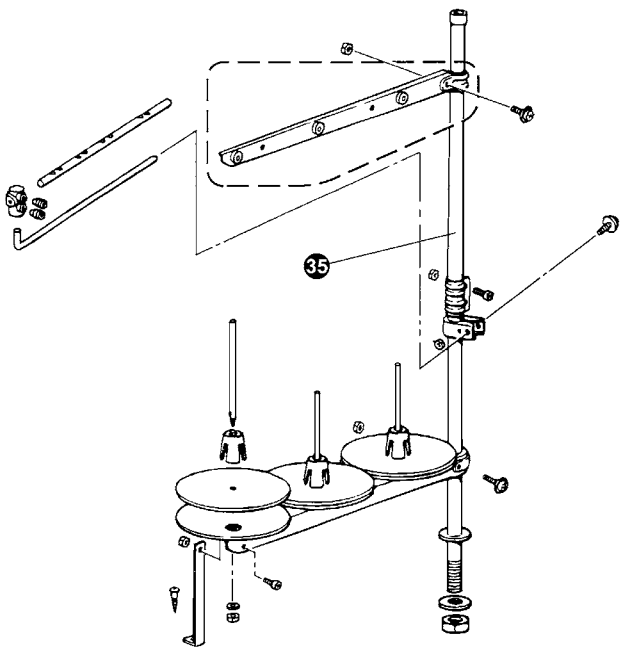

20. ACCESSORIES

No	Ret. No.	Description	Qt			
			3	4/4H	5	5H
35	086700212	Spool stand for three	1			
36	088900101	Spool stand for four		1		
37	031380002	Spool stand for five			1	1

2000 –4H –A

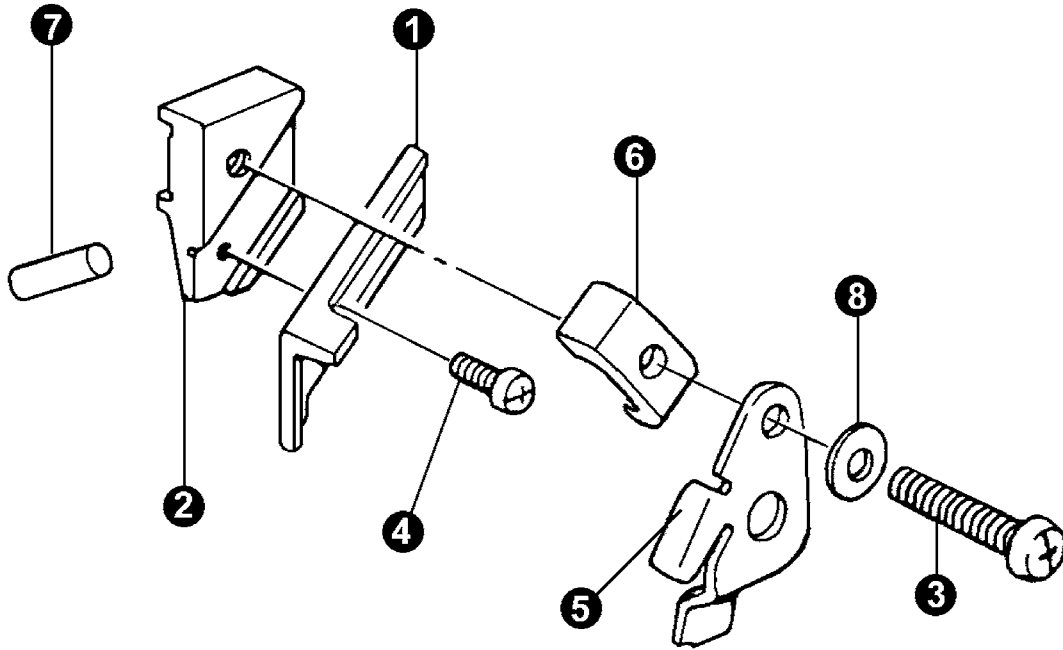

Special –use parts for 2000 –4H –A

No.	Ret. No.	Description	Qt
1	159600006	Upper knife	1
2	159600007	Upper knife holder	1
3	159600008	Screw	1
4	S150217009	Screw M3 x 4	1
5	155600014	Guide board	1
6	155600015	Fixed board	1
7	155600017	Pin	1
8	S8A3103003	Washer 4	1

Note: Spare parts of 2000 –4H –A employ the same parts of 2000 –4H

2000 – 5H – A

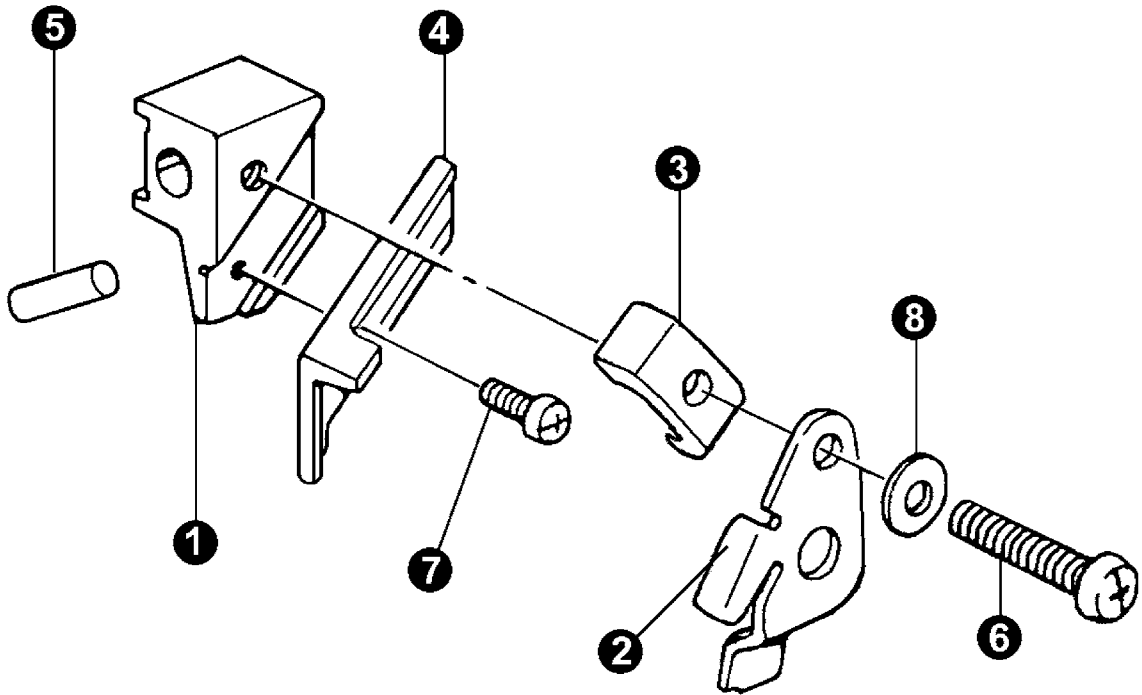

Special – use parts for 2000 – 5H – A

No.	Ret. No.	Description	Qt
1	155600019	Upper knife holder	1
2	155600014	Guide board	1
3	155600015	Fixed board	1
4	155600016	Upper knife	1
5	155600017	Pin	1
6	155600018	Screw	1
7	S150217009	Screw M3 x 4	1
8	S8A3103003	Washer 4	1

Note: Spare partes of 2000 – 5H – A employ the same parts of 2000 – 5H

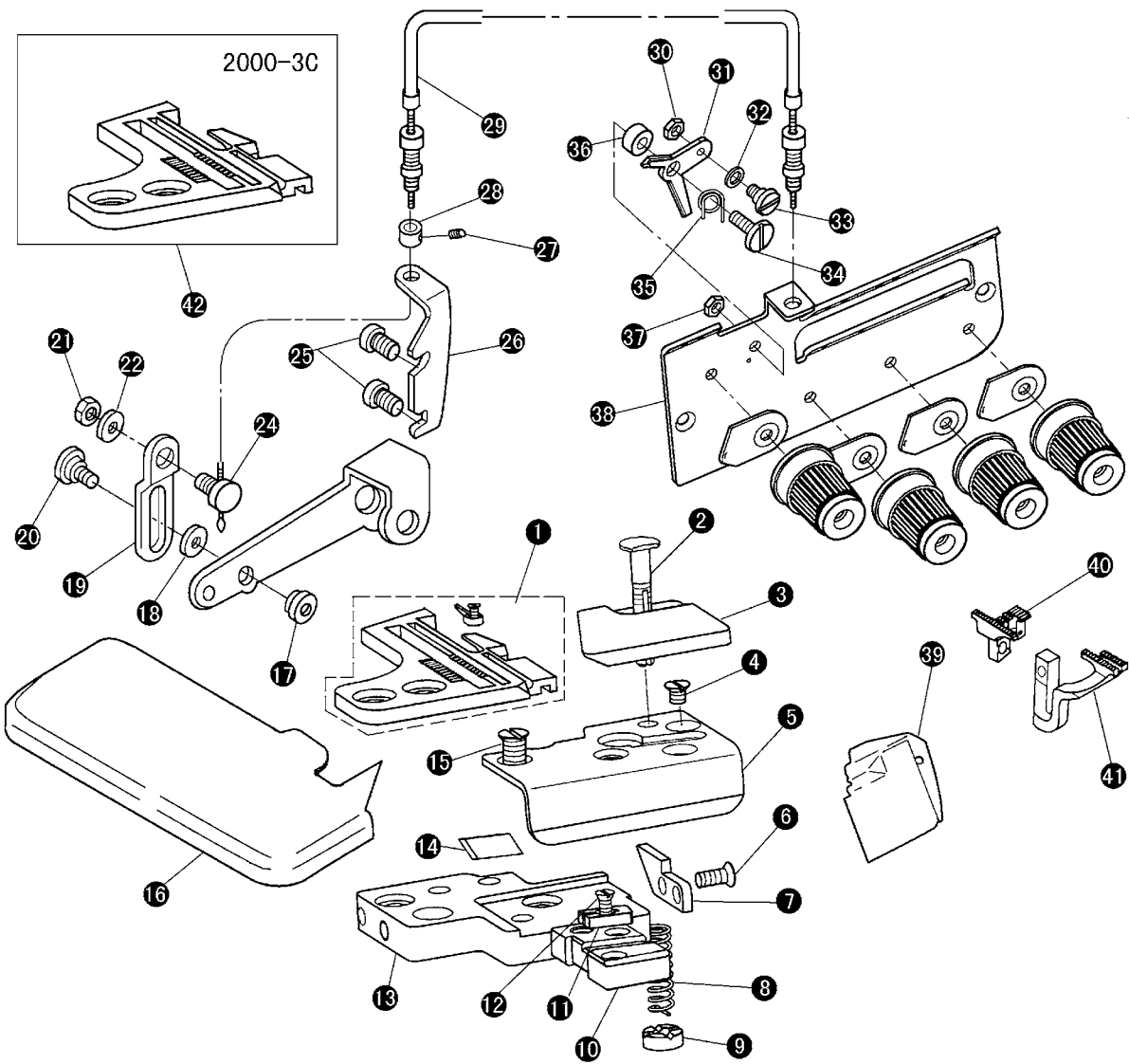

Special – use parts for 2000 –3C 2000 –4C

No	Ret. No.	Description	Qt	
			3C	4C
1	159A41000	Needle plate complete		1
2	109210009	Screw	1	1
3	159A40005	Cutter protect plate	1	1
4	028400059	Screw	2	2
5	159A40003	Thread cut guide plate	1	1
6	028400059	Screw	2	2
7	159A40001	Needle plate guide plate	1	1
8	109210010	Spring	1	1
9	109210011	Nut	1	1
10	109210005	Knife support bracket	2	2
11	109210006	Block	1	1
12	109210007	Screw	1	1
13	159A40002	Needle plate block (Front)	1	1
14	020101035	Knife (width 9mm)	1	1
15	159A40004	Screw	2	2
16	159A00002	Sewing plate complete	1	1
17	159A30003	Screw	1	1
18	159A23006	Washer	1	1
19	159A30001	Plate	1	1
20	159A30002	Screw	1	1
21	S120501011	Nut M6	1	1
22	S150633001	Washer 6	1	1
23	159A30004	Screw	1	1
24	S150217013	Screw M6 10	1	1
25	159A00003	Thread support plate	2	2
26	182610010	Screw	1	1
27	159A00004	Block	1	1
28	159A22000	Soft thread complete	1	1
29	028100035	Nut	1	1
30	159A23001	Thread lease rack	1	1
31	159A23006	Washer	1	1
32	159A23004	Screw	1	1
33	159A23002	Screw	1	1
34	159A23005	Spring	1	1
35	159A23003	Block	1	1
36	028100035	Nut	1	1
37	159A21001	Thread guide plate	1	1
38	159A10001	Drawing	1	1
39	160510000	Mainfeed dog complete	1	1
40	160500001	Differential feed dog	1	1
41	160A30000	Needle plate complete	1	

Note: Spare parts of 2000 –3C/4C employ the same parts of 2000 –3. 2000 –4H

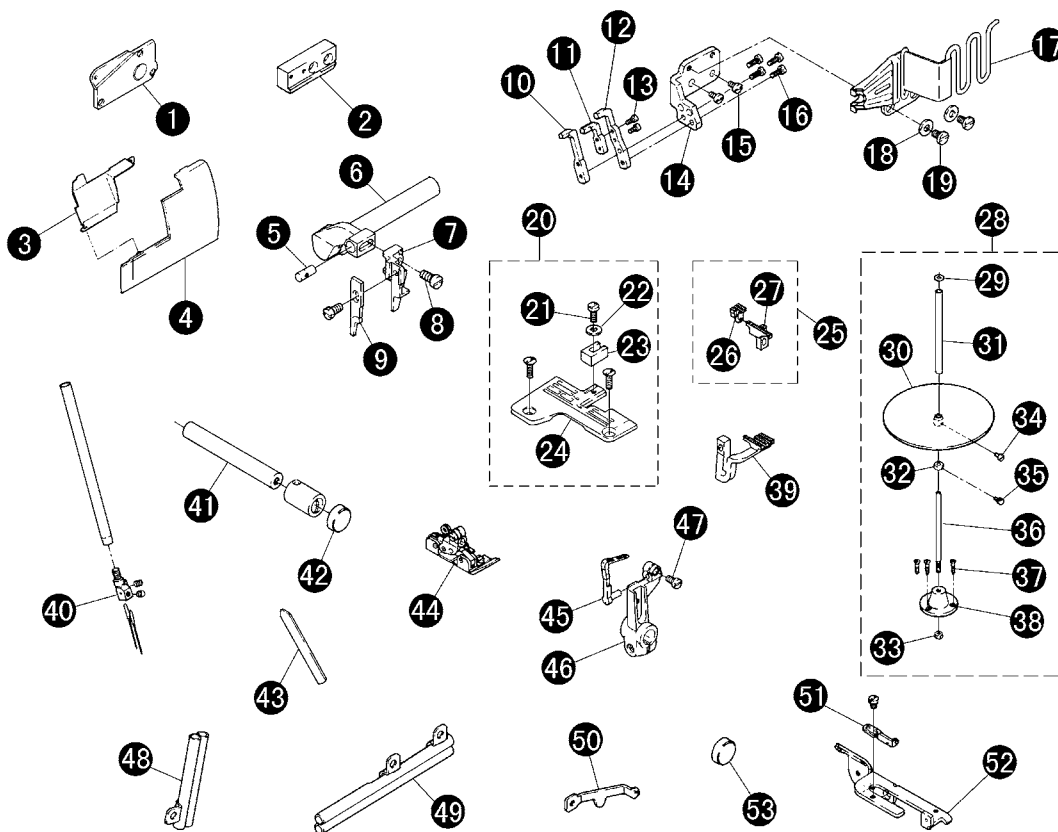

Special – use parts for 2000 –4G

No.	Ret. No.	Description	Qt
1	155E10000	Cover	1
2	155E00002	Edge binder support bracket	1
3	155E20002	Front cover	1
4	155E20001	Front cover(L)	1
5	155E00011	Pin	1
6	155E00009	Upper knife bar	1
7	155E00010	Upper knife holder	1
8	028500032	Screw	1
9	155E00012	Upper knife	1
10	155E00004	Needle guard (rear)	1
11	155E00005	Chain stitch needle guard (rear)	1
12	155E00003	Needle guard (front)	1
13	028400004	Screw	1
14	155E00006	Plate	1
15	S150215001	Screw	1
16	028200061	Screw	1
17	155E60000	Edge binder complete	1
18	155E00007	Washer	1
19	SFB0201020	Screw	1
20	155E70000	Needle plate baracket	1

Note: Spare parts of 2000 –4G employ the same parts of 2000 –5

Special – use parts for 2000 – 4G

No	Ret. No.	Description	Qt
21	028200061	Screw	1
22	028400004	Washer	1
23	155E70002	Needle cloth guide	1
24	155E70001	Needle plate	1
25	155E80000	Main feed dog complete	1
26	155E80002	Auxible feed dog	1
27	155E80001	Main feed dog	1
28	155Eg0000	Belt plate dig complete	1
29	155Eg0006	Felt	1
30	155Eg1000	Belt plat small complete	1
31	155Eg0003	Rack	1
32	155Eg0005	Bush	1
33	S120501011	Nut	1
34	S150237006	Screw	1
35	155Eg0004	Screw	1
36	155Eg0002	Support rack	1
37	W050101002	Screw	1
38	155Eg0001	Base mechanism	1
39	155E00008	Differential feed dog	1
40	155E50001	Needle holder	1
41	155E00016	Upper looper shaft	1
42	022500005	Oil seal	2
43	155E00014	Lower knife	1
44	155Ea0000	Presser foot complete	1
45	155E90001	Small looper	1
46	155E90002	Front looper holder	1
47	028100007	Screw	1
48	155Ee0000	Double short thread pipe	1
49	155Ed0000	Double long thread pipe	1
50	155E00015	Thread guide plate	1
51	155Eh0002	Right thread guide	1
52	155Eh0001	Lower thread guide bracket	1
53	028160001	Upper looper oil seal	1

Special – use parts for 2000 –4XH

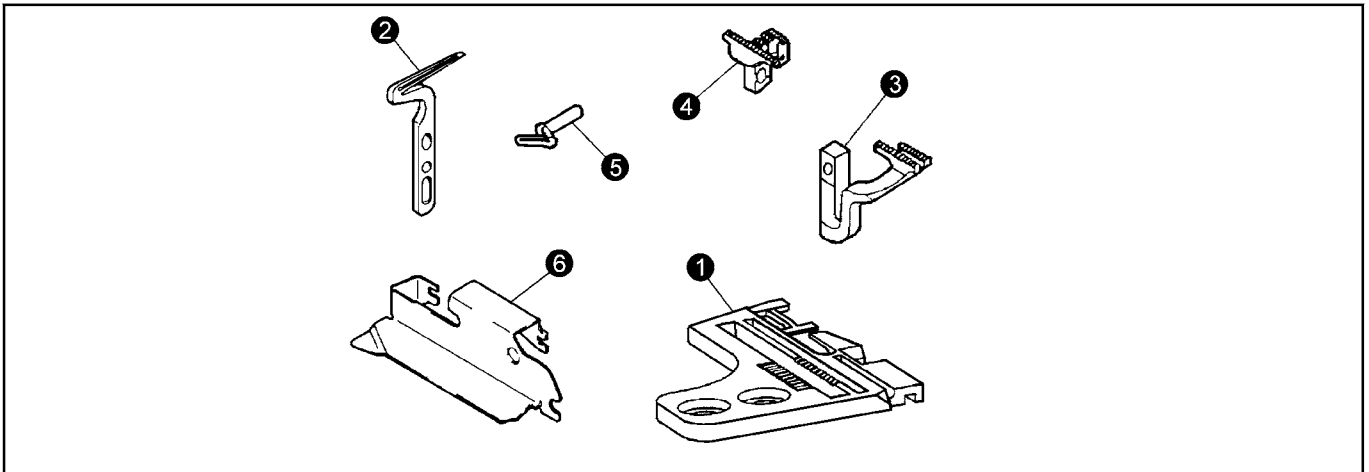

No	Ret. No.	Description	Qt
1	159350000	Needle plate asm	1
2	159400003	Lower looper	1
3	159500002	Differential feed dog	1
4	159520000	Main feed dog asm	1
5	159400004	Upper looper	1
6	159150000	Cloth guide asm	1

Note: Spare parts of 2000 –4XH employ the same parts of 2000 –4H –A

Special – use parts for 2000 –5L

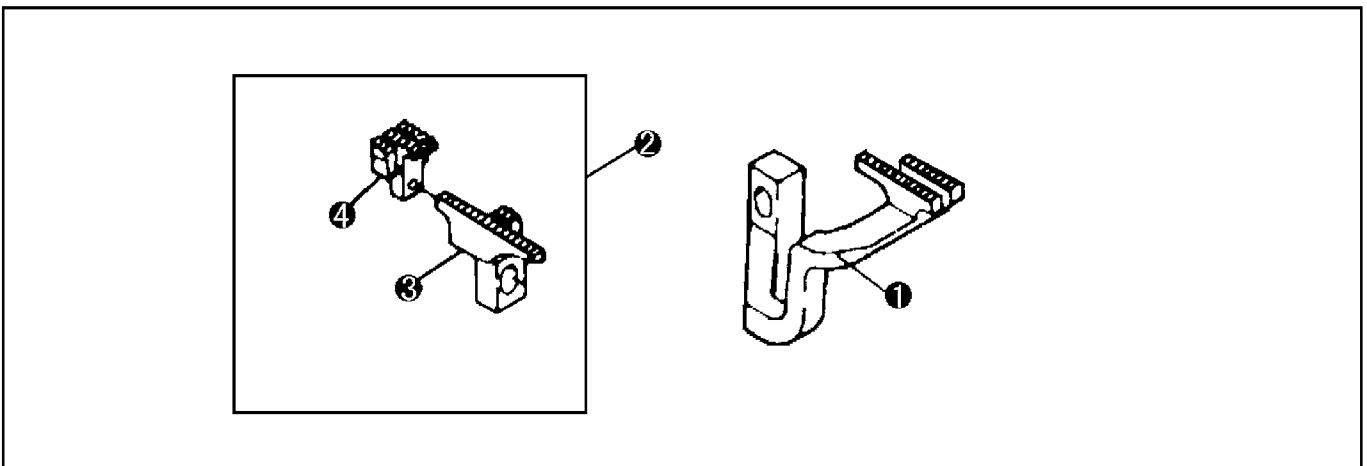

No	Ret. No.	Description	Qt
1	155500052	Differential feed dog	1
2	155590000	Main feed dog asm	1
3	155590001	Main feed dog	1
4	155590002	Auxible feed dog	1

Note: Spare parts of 2000 –5L employ the same parts of 2000 –5(3×4)

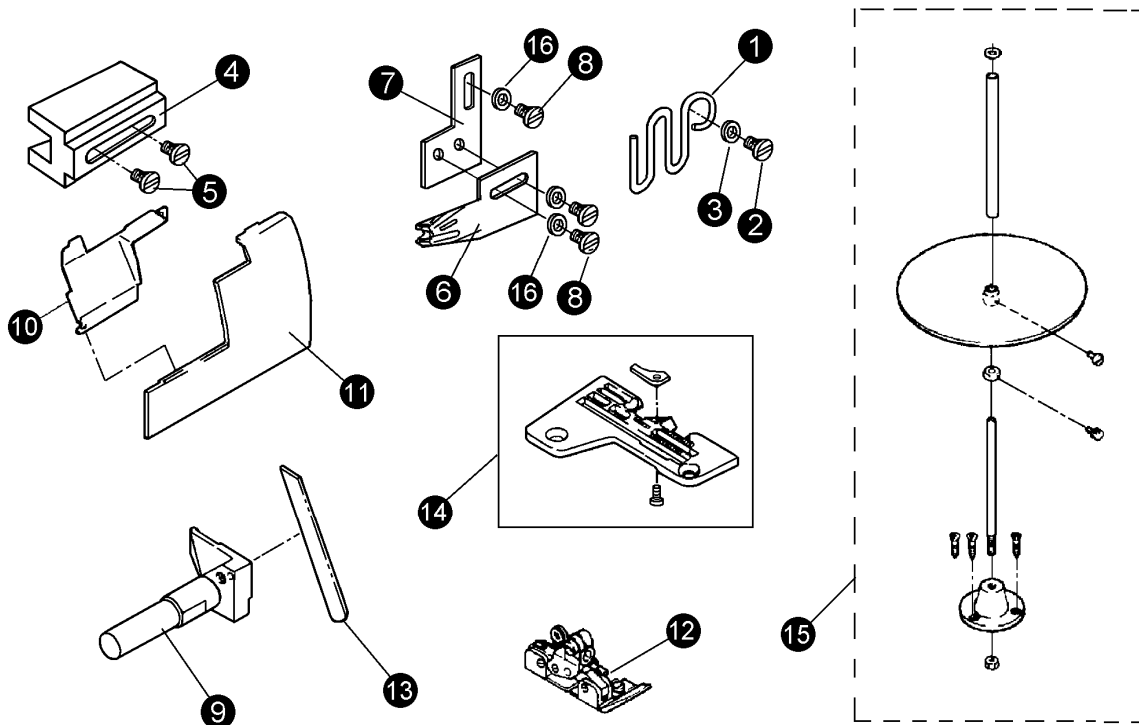

Special-use parts for 2000-5/BB 2000-6/BB

No	Ret.No.	Description	Qt	
			-5/BB	-6/BB
1	155K00002	Strap guide holder	1	1
2	S150215010	Screw M4x12	1	1
3	155900017	Washer	1	1
4	155K00003	Block	1	1
5	159600008	Screw	2	2
6	155K00004	Edge former (8mm)	1	
	155S00002	* Edge former (12mm)		1
	155S00003	* Edge former (14mm)		1
7	155K00005	Block	1	1
8	S150215001	Screw M4x8	3	3
9	155K00006	Lower knife holder	1	1
10	155K00007	Front cover	1	1
11	155E20001	Front cover (L)	1	1
12	155K20000	Presser foot complete	1	
	155S10000	Presser foot complete		1
13	159600004	Lower knife	1	1
14	155K30000	Needle plate complete (3x4)	1	1
	155S00001	Needle plate complete	1	
15	155Eg0000	Edge rotating plate complete	1	1
16	S150632001	Washer	3	3

Note: Spare parts of 2000-5BB、2000-6BB employ the same parts of 2000-5. * Optional parts.

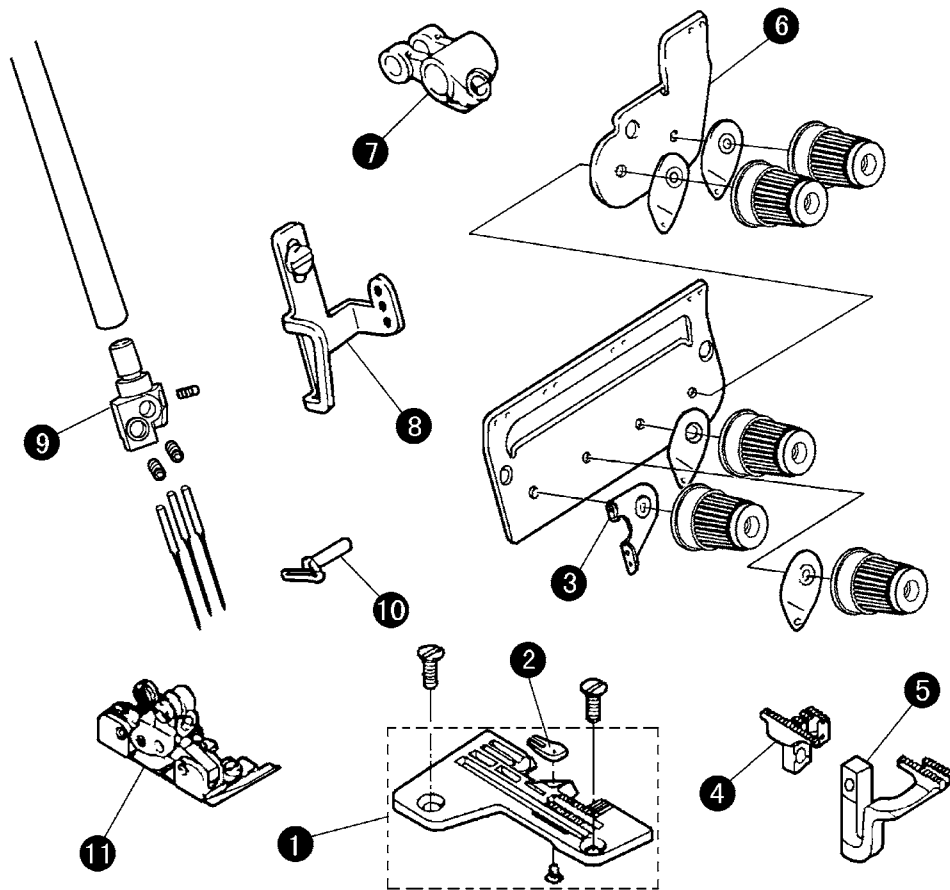

Special – use parts for 2000 – 6

No	Ret. No.	Description	Qt
1	155G10000	Needle plate complete	1
2	155G10001	Needle plate fitting	1
3	155G40002	Thread guide plate	1
4	1555a0000	Main feed dog complete	1
5	155500051	Differential feed dog	1
6	155G40001	Thread guide plate(S)	1
7	155370001	Upper shaft crank	1
8	155G00003	Needle thread guide plate	1
9	155G20000	Needle holder	1
10	155G00002	Upper looper	1
11	155G30000	Presser foot complete	1

Note: Spare parts of 2000 –6 employ the same parts of 2000 –5

Special – use parts for 2000 – 3B

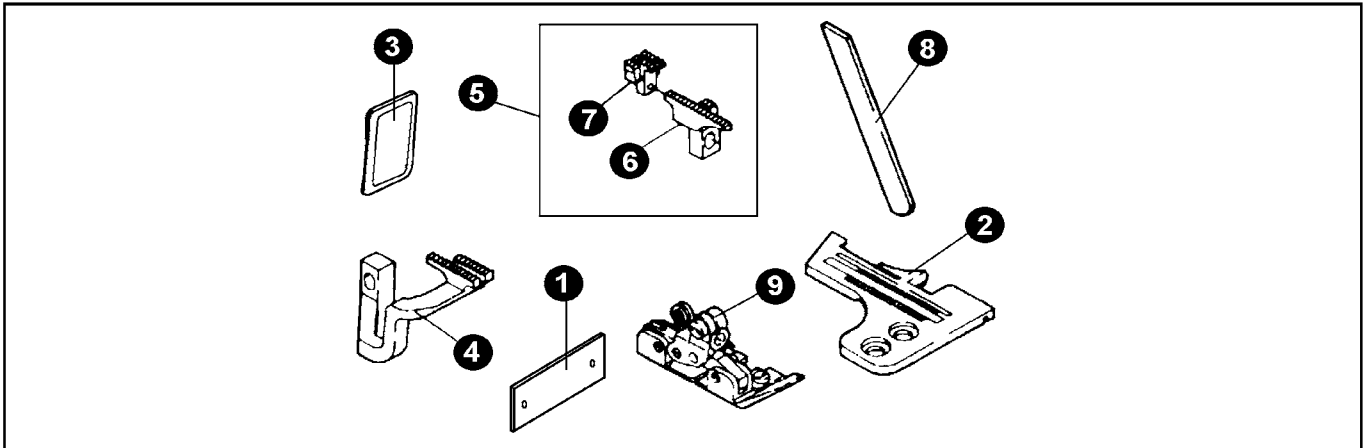

No.	Ret. No.	Description	Qt
1	160100003	Model plate	1
2	160300004	Needle plate	1
3	028280009	Needle (DCX27)	1
4	160500003	Differential feed dog	1
5	160520000	Main feed dog complete	1
6	160520001	Main feed dog	1
7	160520002	Auxible feed dog	1
8	160600001	Lower knife	1
9	160740000	Presser foot complete	1

Note: Spare parts of 2000 – 3B employ the same parts of 2000 – 3.

Special – use parts for 2000 – 3E

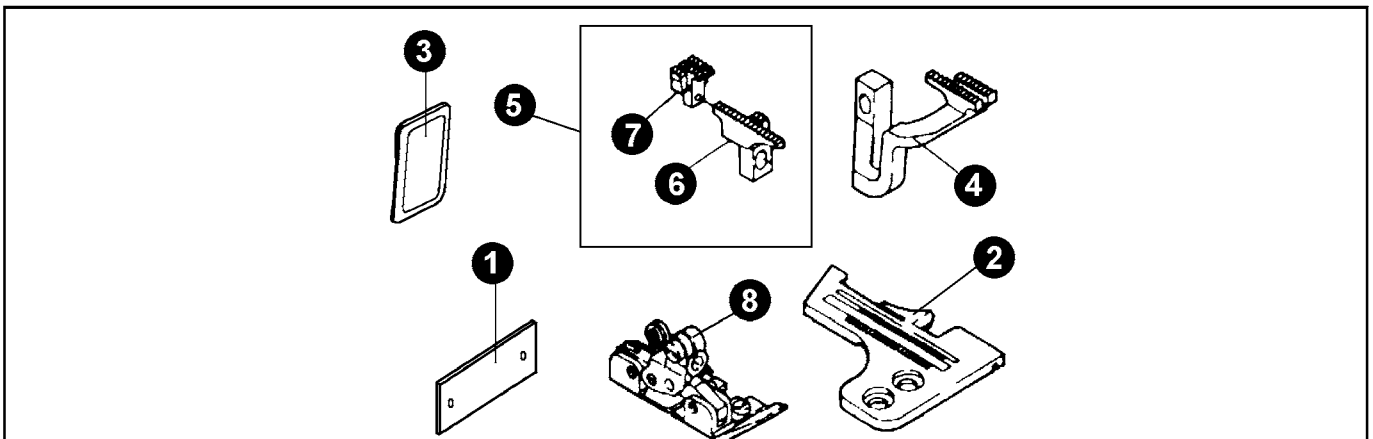

No.	Ret. No.	Description	Qt
1	160100004	Model plate	1
2	160300004	Needle plate	1
3	028280009	Needle (DCX27)	1
4	160500004	Differential feed dog	1
5	160530000	Main feed dog complete	1
6	160530001	Main feed dog	1
7	160530002	Auxible feed dog	1
8	160750000	Presser foot complete	1

Note: Spare parts of 2000 – 3E employ the same parts of 2000 – 3.

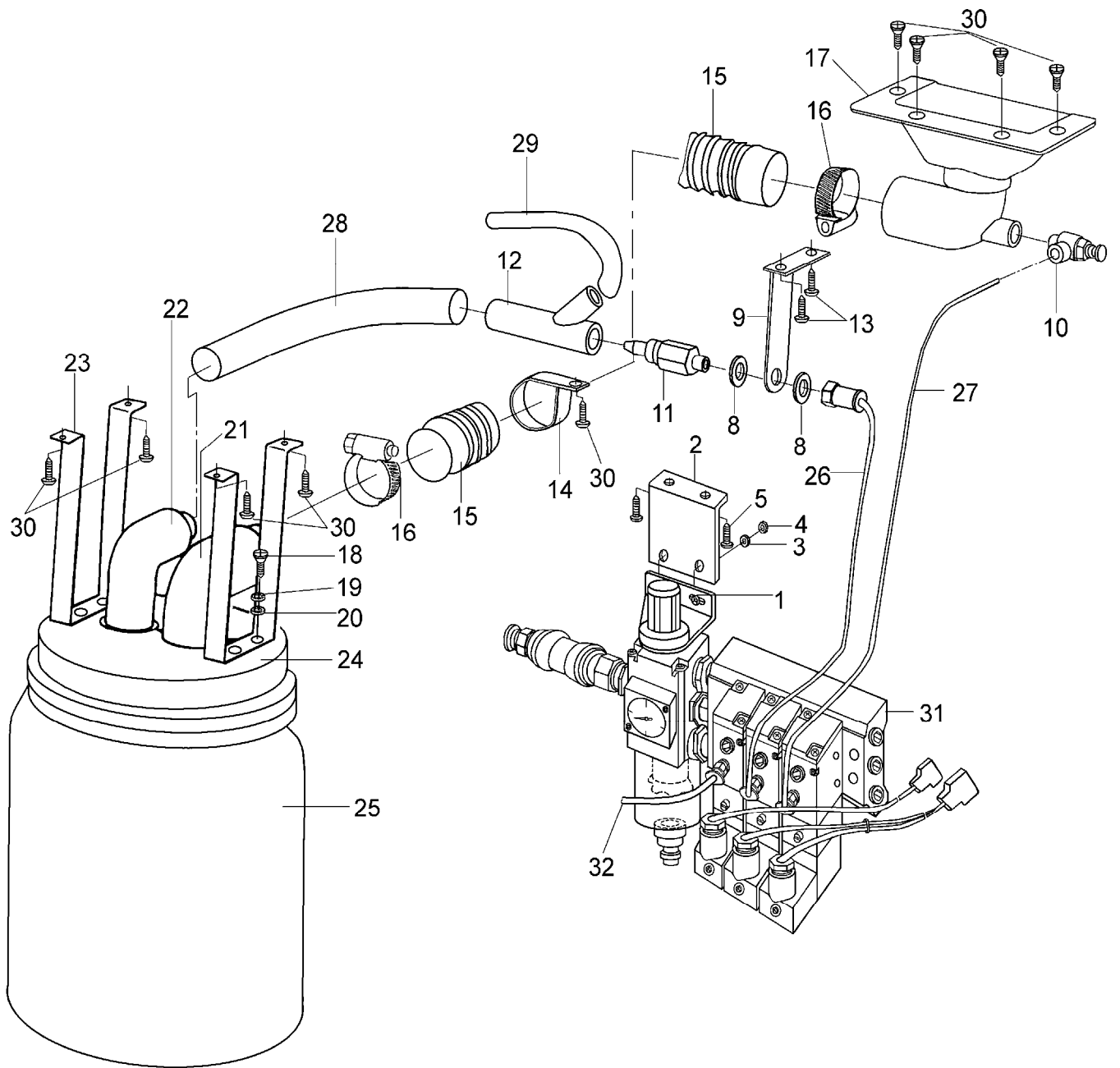

Special —use parts for 2000/P3D

No.	Ret. No.	Description	Qt	Note
1	GB818-85	Screw M5X10	2	
2	W70-WX04-05	Bracket 54X56X17X2	1	
3	GB93-87	Washer 5	2	
4	GB6170-86	Nut M5	2	
5	GB845-85	Screw ST4.2X17-C-H	2	
8	GB845-85	Washer 10	2	
9	W70-WX04-06	Bracket (2)	1	
10		Air throttle	1	Pipe PU-6
11	W70-WX04-08	Spray head 19X63	1	
12	W70-WX04-07	Linksφ 20.2X78	1	
13	GB845-85	Screw ST4.2X12-C-H	2	
14	W70-WX06-07g	Bracket folder	1	
15	W70-WX06-10	Nylon tube (φ 39Xφ 46)	1	L=800
16		Pipe chuck	2	
17	W70-WX06-08g	Funnel	1	
18	GB818-85	Screw M4X12	4	
19	GB859-86	Washer 4	4	
20	GB97.1-85	Washer 4	4	
21	W70-WX06-01	90-Degree big bend	1	
22	W70-WX06-02	90- Degree small bend	1	
23	W70-WX06-03	Pylon	2	
24	W70-WX06-04	Disc	1	
25	W70-WX06-05	Ring belt	1	
26	PU-6	Pipe 6X4	1	L=600
27	PU-6	Pipe 6X4	1	L=400
28		Nylon tubeφ 18Xφ 25	1	L=300
29		Nylon tubeφ 12Xφ 16	1	L=500
30	GB845-85	Screw ST4.2X12-C-H	9	
31	159R50000	Solenoid valve assy	1	
32	PU-6	Pipe 6X4	1	L=1200

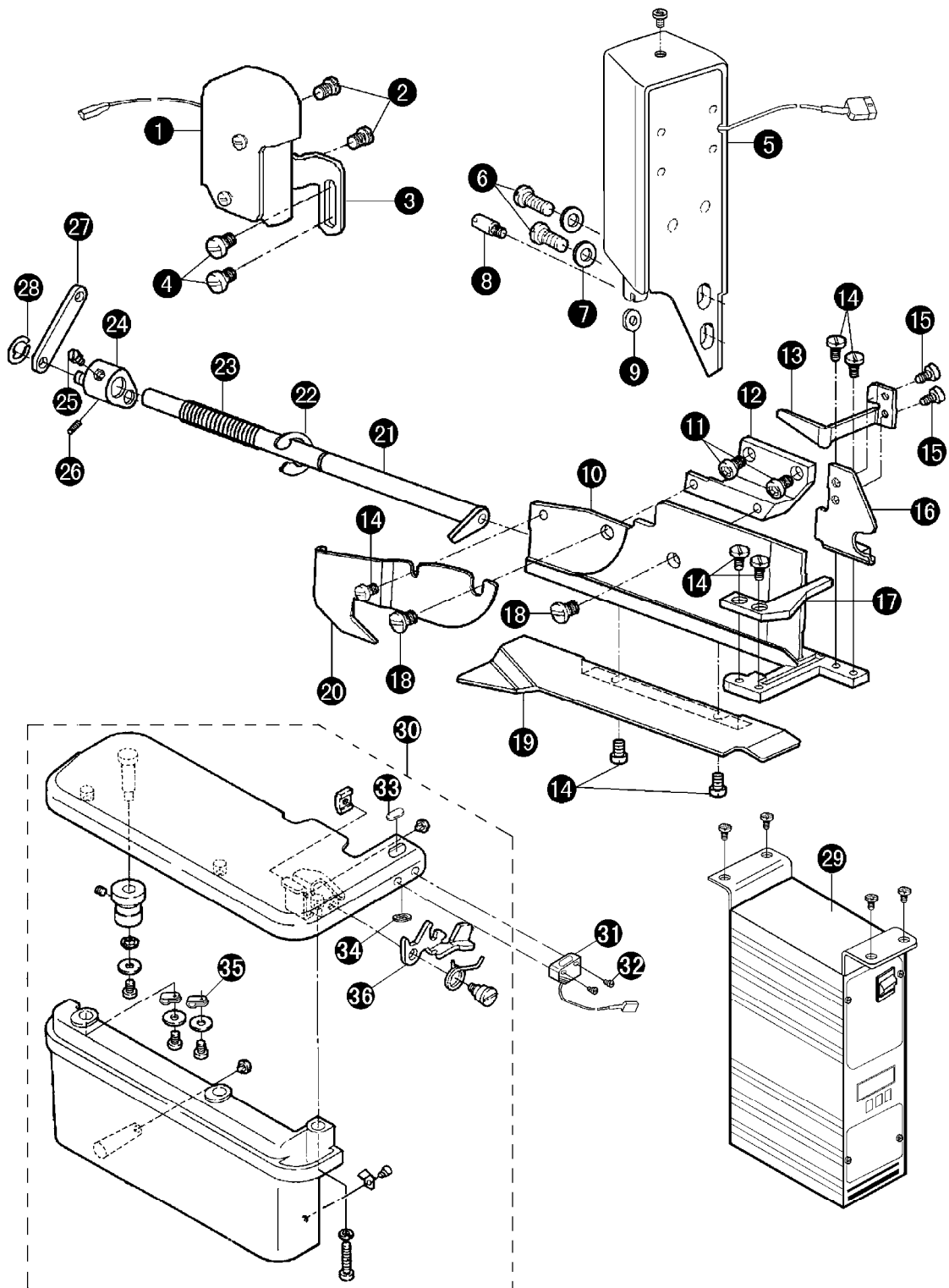

Special —use parts for 2000ET/ET-1

No.	Ref. No.	Description	Qt.			
			3/4ET	5/6ET	3/4ET-1	5/6ET-1
1	159M30000	Switch assy.	1	1	1	1
2	S150218005	Screw M4 × 6	2	2	2	2
3	159C00001	Joint plate	1	1	1	1
4	S150237007	Screw M4 × 6	2	2	2	2
5	159M20000	Solenoid assy.	1	1	1	1
6	S150220014	Set screw M6 × 12	2	2	2	2
7	S150667002	Washer 6	2	2	2	2
8	036900002	Screw	1	1	1	1
9	036954116	Spring washer	1	1	1	1
10	159C10004	Thread cutter holder	1	1	1	1
11	S150220032	Set screw M6 × 10	2	2	2	2
12	159C00002	Joint bracket	1	1	1	1
13	159C10006	Thread cutter guard	1	1	1	1
14	159C10009	Screw M3	7	7	7	7
15	S150217001	Screw M2.5 × 3	2	2	2	2
16	155H10003	Guard bracket	1	1	1	1
17	159C10005	Fixing cutter	1		1	
	155H10001	Fixing cutter		1		1
18	159300006	Screw SM 4.37 × 40	2	2	2	2
19	159C10003	Guard plate	1	1	1	1
20	159C10008	Crank guard	1	1	1	1
21	159C11000	Thread cutter assy.	1	1	1	1
22	159C10002	Collar	1	1	1	1
23	159C10001	Spring	1	1	1	1
24	159C12000	Crank assy.	1	1	1	1
25	028400035	Screw	1	1	1	1
26	159C10010	Screw SM 4.37 × 40	1	1	1	1
27	028A00009	Cutter link	1	1	1	1
28	SFB1403003	Collar 2.5	1	1	1	1
29	998281100	Control box assy.	1	1	1	1
30	159M10000	Sewing Platform assy.	1		1	
	155N10000	Sewing Platform assy.		1		1
31	159R70000	Synchronizer			1	1
32	S150218020	Screw M3 × 10			2	2
33	159M10002	Observe window	1	1	1	1
34	159M10003	Sponge washer	1	1	1	1
35	213000020	Nylon Spool stand	2	2	2	2
36	159M10004	Latch lock wrench	1	1	1	1

Note: 1、 Switch off the automatic thread trimmer and use manual switch when using special light black or yarn material in et-1 series.

2、 If do not need the automatic thread trimming, the sensor can be unplugged, attached the manual switch in the attachment box, adjust the parameter according to the instructions.

2000 SERIES GAUGE PARTS LIST

MACHINE TYPE/SPEC	GAUGE		NEEDLE PLATE	NEEDLE PLATE FINGER	MAIN FEED DOG ASSM	MAIN FEED DOG	AUX. FEED DOG	DIFF. FEED DOG	PRESSER FOOT ASS.	UPPER LOOPER	LOWER LOOPER	CHAINSTITCH LOOPER
	NG	SW										
2000 -5L	3	4	155390000	155390002	155590000	155590001	155590002	155500052	03971	155400015	155450002	155710002
2000 -5	3	4	155390000	155390002	1555a0000	1555a0001	1555a0002	155500051	03971	155400015	155450002	155710002
2000 -5(3 x5)	3	5	1553a0000	155340002	1555a0000	1555a0001	1555a0002	155500051	03971	155400015	155450002	155710002
2000 -5(5 x5)	5	5	155340000	155340002	155520000	155520001	155520002	155500021	039720000	155400015	155450002	155710002
2000 -5H	5	6	155380000	155380002	155580000	155580001	155520002	155500050	07771	155400025	155450002	155730001
2000 -5H -A	5	6	155380000	155380002	155580000	155580001	155520002	155500050	07771	155400025	155450002	155730001

MACHINE TYPE/SPEC	GAUGE		UPPER KNIFE	LOWER KNIFE	OVERLOCK NEEDLE GUARD		OVERLOCK NEEDLE GUARD REAR	OVERLOCK NEEDLE GUARD		NEEDLE BAR ASSM	NEEDLE HOLDER	NEEDLE
	NG	SW			FRONT	REAR		FRONT	REAR			
2000 -5L	3	4	155600008	155600011	155300025	155300024	155300024	155300031	155300032	155360000	155360002	DC x27 11#
2000 -5	3	4	155600008	155600011	155300025	155300024	155300024	155300031	155300032	155360000	155360002	DC x27 14#
2000 -5(3 x5)	3	5	155600008	155600011	155300025	155300024	155300024	155300031	155300032	155360000	155360002	DC x27 14#
2000 -5(5 x5)	5	5	155600008	155600011	155300025	155300024	155300024	155300027	155300026	155350000	155350002	DC x27 14#
2000 -5H	5	6	155600008	155600011	155300025	155300024	155300024	155300027	155300026	155350000	155350002	DC x27 21#
2000 -5H -A	5	6	155600008	155600011	155300025	155300024	155300024	155300027	155300026	155350000	155350002	DC x27 21#

MACHINE TYPE/SPEC	GAUGE		NEEDLE PLATE	NEEDLE PLATE FINGER	MAIN FEED DOG ASSM	MAIN FEED DOG	AUX. FEED DOG	DIFF. FEED DOG	PRESSER FOOT ASS.	UPPER LOOPER	LOWER LOOPER
	NG	SW									
3100 -3 (/2)	—	4	160300001	—	160510000	160510001	160510002	160500001	160710000	160400001	155450002
3100 -3	—	4	160300003	—	159510000	159510001	159510002	159500001	160730000	160400001	155450002
3100 -3B	—	1.5	160300004	—	160520000	160520001	160520002	160500003	160740000	160400001	155450002
3100 -3E	—	1.5	160300004	—	160520000	160520001	160520002	160500003	160750000	160400001	155450002
3100 -4	2	4	159310000	159310002	159510000	159510001	159510002	159500001	159710000	159400001	155450002
3100 -4M	2	4	159310000	159310002	159510000	159510001	159510002	159500001	159720000	159400001	155450002
3100 -4H	2	4	159310000	159310002	159510000	159510001	159510002	159500001	159720000	159400001	155450002
3100 -4M -A	2	4	159310000	159310002	159510000	159510001	159510002	159500001	159720000	159400001	155450002

MACHINE TYPE/SPEC	GAUGE		UPPER KNIFE	LOWER KNIFE	NEEDLE GUARD		NEEDLE BAR ASSM	NEEDLE HOLDER	NEEDLE
	NG	SW			FRONT	REAR			
3100 -3 (/2)	—	4	155600008	159600004	159300001	155300024	160320000	160320001	DC x27 11#
3100 -3	—	4	155600008	159600004	159300001	155300024	160320000	160320001	DC x27 11#
3100 -3B	—	1.5	155600008	159600004	159300001	155300024	160320000	160320001	DC x27 9#
3100 -3E	—	1.5	155600008	159600004	159300001	155300024	160320000	160320001	DC x27 9#
3100 -4	2	4	155600008	159600004	159300001	155300024	159320000	159320001	DC x27 11#
3100 -4M	2	4	155600008	159600004	159300001	155300024	159320000	159320001	DC x27 14#
3100 -4H	2	4	155600008	159600004	159300001	155300024	159320000	159320001	DC x27 14#
3100 -4M -A	2	4	155600008	159600004	159300001	155300024	159320000	159320001	DC x27 14#

- Besides adjusting stitch, please laypeople don't debug or maintain.
- Parts are subject to changes in design without prior notice.

XI'AN TYPICAL INDUSTRIES CO., LTD.

Add: No. 335 Taibai South Road,
Xi'an, P. R. China - 710068

Tel : +86 -29 -88279091 88279150

Fax : +86 -29 -88249715 88245215

E-mail: typical@chinatypical.com

[Http: www.chinatypical.com](http://www.chinatypical.com)

[Http: www.globalsources.com](http://www.globalsources.com)

GN2000

HIGH-SPEED OVERLOCK SEWING MACHINE



Certificate of the international ISO9001



Certificate of the ISO14001



Certificate of the international CE



Certificate for Ecolabeling Product



Certificate for Energy Conservation Product

XI'AN TYPICAL INDUSTRIES CO., LTD.

No. 335, South Taibai Road
Xi'an 710068, P.R.China
Tel.: +86-29-88279093 // 88279150 // 88279151
Fax: +86-29-88249715 // 88245215

E-mail: tic@chinatypical.com
www.chinatypical.com

XI'AN TYPICAL EUROPE GmbH

Hertelsbrunnenring 9
D-67657 Kaiserslautern
Tel.: +49 (0)631 316019-0
Fax: +49 (0)631 316019-11

E-mail: sales@typical-europe.com
www.typical-europe.com