

# TW1-1245

INSTRUCTION BOOK // PARTS CATALOGUE



COMPOUND FEED LOCKSTITCH SEWING MACHINE

**TYPICAL**

# CONTENTS

## Operation instruction

1. Brief introduction	4
2. Main technical specifications	1
3. Feed adjustment/reverse stitching	1
4. Adjusting upper feed stroke	1
5. Winding bobbin thread	2
6. Adjusting the bobbin thread tension	2
7. Threading the needle thread/adjusting the tension of needle thread	2
8. Maintenance	3
9. Oiling	3
10. Lubricating the hook	4
11. Lubricating the machine head	4
12. Lubricating upper feed driving eccentric	4
13. Adjusting the feed dog	5
14. Pre-adjusting the needle height	6
15. Centering the needle in the needle hole	6
16. Adjusting the bottom feed dog position	6
17. Adjusting the upper and the lower feed	7
18. Position of needle and rotating hook	7
19. Adjusting the lifting amount of alternating presser foot.	7
20. Top feed adjustment	8
21. Adjusting the bobbin case opener	8
22. Safety clutch	8
23. Needle thread tension release	9
24. Bobbin thread winder	9

## Parts manual

1. Machine casting components	10-11
2. Needle and presser foot components	12-15
3. Presser foot lifting components	16-17
4. Thread take-up and thread tension components	18-19
5. Feed adjustment components	20-21
6. Upper shaft and rocking shaft components	22-23
7. Timing belt components	24-25
8. Rotating hook saddle components	26-27
9. Needle plate and hook components	28-29
10. Lower feed components	30-31
11. Lower shaft components	32-33
12. Knee lifter components	34-35
13. Binder Components	8-39
14. Accessories	8-39

# **OPERATION INSTRUCTION**

## 1. Brief introduction

TW1-1245 adopts compound feed mechanism with synchronous top, bottom and needle feed and the max amount of alternating presser foot lifter reaches 7 mm, which guarantees the high sewing quality of different materials. Besides, TW1-1245 adopts the large auto-lubricating horizontal rotating hook, 4-link thread take-up lever and timing belt, which assures its lower noise and high speed.

This machine is widely used in manufacturing suitcase, tents, cushions, leather products, clothes bamboo matting, etc.

## 3. Feed adjustment/reverse stitching(Fig.1)

1. Adjusting the stitch length by turning Nut 1;
2. When backward stitching, push Nut 1 to Mark R as much as possible.

## 2. Main technical specifications

Applications	Medium & heavy weight materials
Max. Sewing speed	2000s.p.m
Max. Stitch length	8mm
Needle bar stroke	36mm
Needle	DP×35 80~140Nm
Lubrication	By hand(partly)
Motor power	370W

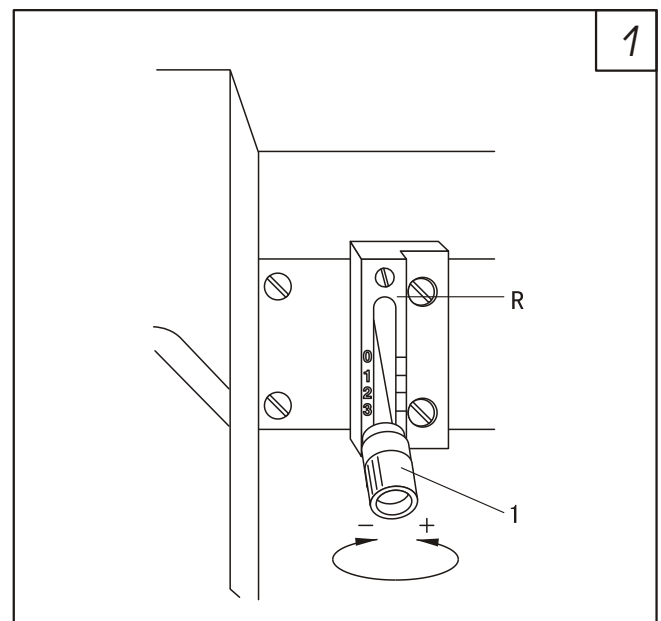

## 4. Adjusting upper feed stroke(Fig.2)

Open the rear cover 1; loosen the screw 2, and as required, move it up and down.

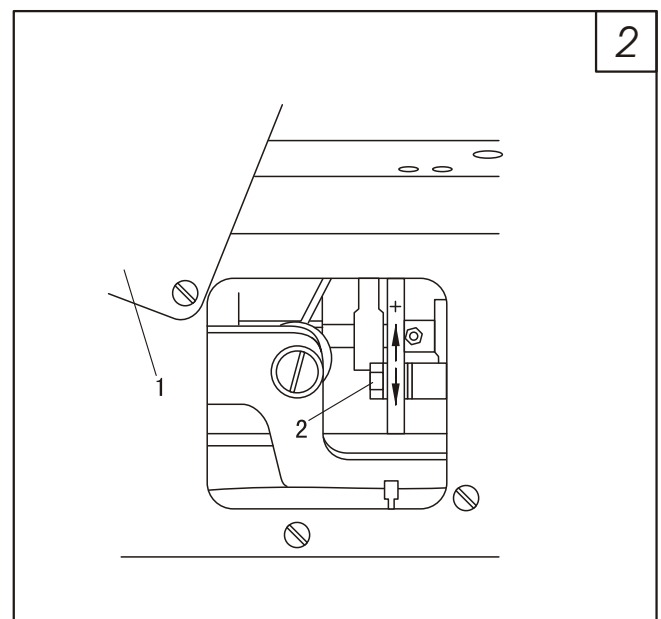

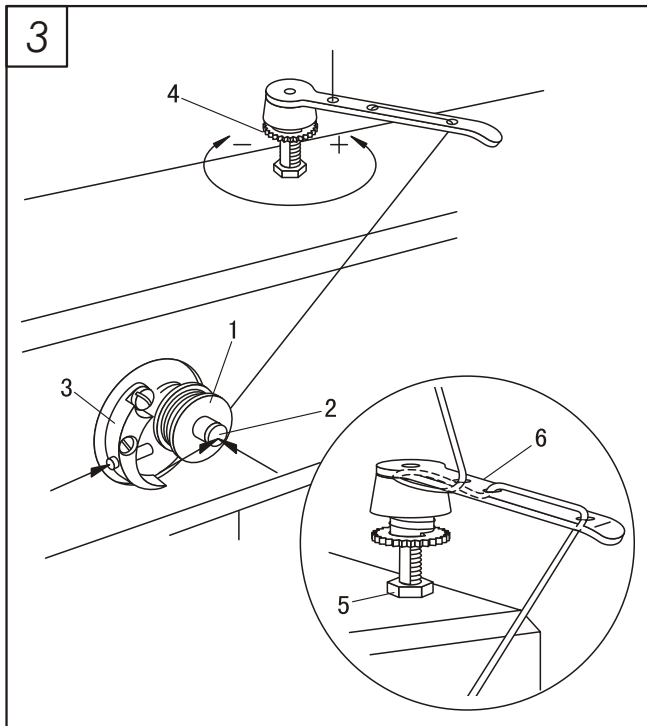

### 5. Winding bobbin thread(Fig.3)

1. Put the bobbin into the bobbin shaft 2;
  2. As Fig 3 shows, draw out the thread and winding clockwise to the bobbin several times;
  3. Before winding, press down the winding shaft 2 and the hook gib 3;
  4. Adjusting the bobbin 1 thread tension by the screw 4;
  5. When the bobbin is full, the bobbin winder will automatically stop.
- If the winding is abnormal, loosen the screw 5, and as required, move the thread guide 6, then tighten the screw 5.

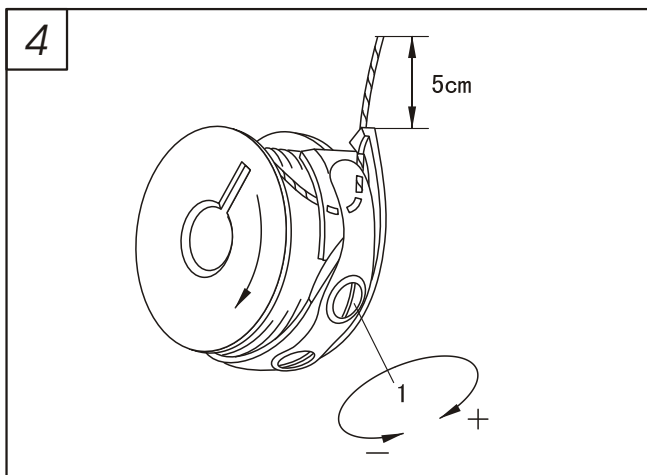

### 6. Adjusting the bobbin thread tension(Fig.4)

1. As Fig.4 shows, draw out the bobbin thread;
- ※ When the bobbin thread is drawn out, the bobbin should run as the arrow goes.
2. Adjusting the bobbin thread tension by the screw 1.

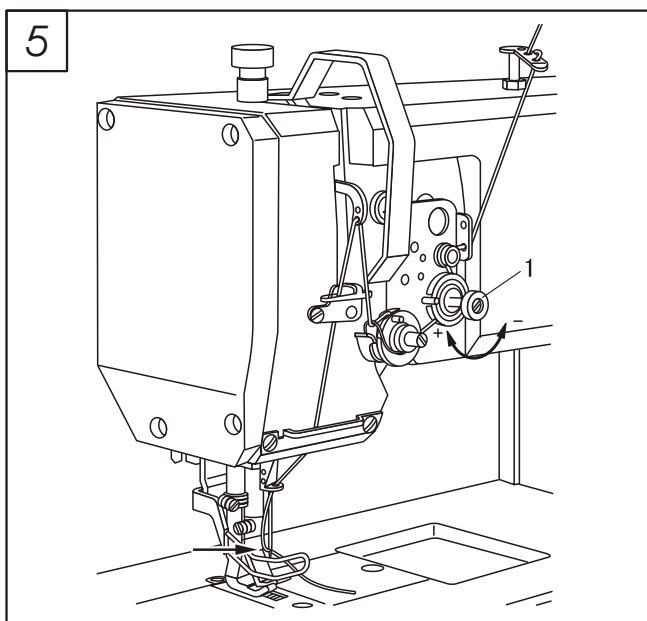

### 7. Threading the needle thread/adjusting the tension of needle thread(Fig.5)

1. Threading as the Fig 5 shows.
- ※ Pass the thread to the eye of needle from the left side(Fig.arrow)
2. Adjusting the needle thread tension by the screw 1

## 8. Maintenance

Clean the bobbin clearance	Once a week
Normal oiling	Twice a week
Front parts oiling	Twice a week
Check the hook oil box	Once a week
Clean the rotating hook	Once a week
Upper feed driving eccentric oiling	once a year

※ The above data is due to the normal situation. If the machine is used frequently, the interval of the maintenance should be shortened.

Maintenance for rotating hook(Fig.6)

1. Clean the rotating hook with brush every day, and constant use needs more frequent cleansing.
2. Clean the rotating hook thoroughly every week. As follows:
  - a. Open the slide plate and lift the needle bar to its highest point;
  - b. Take out the bobbin cap and the bobbin;
  - c. Release the hook gib 1; turn over the balance wheel until the Point 2 passes to the groove 5mm; then take out the bobbin case;
  - d. Clean the rotating hook track with paraffin wax;
  - e. When the bobbin case is installed, the horn 5 and needle plate groove must be closely touched; (Fig. Arrow)
- Tighten the hook gib 1, install the bobbin case and close the slide plate.

## 9. Oiling(Fig.7)

The machine must be oiled at the mark(arrow) twice a week.

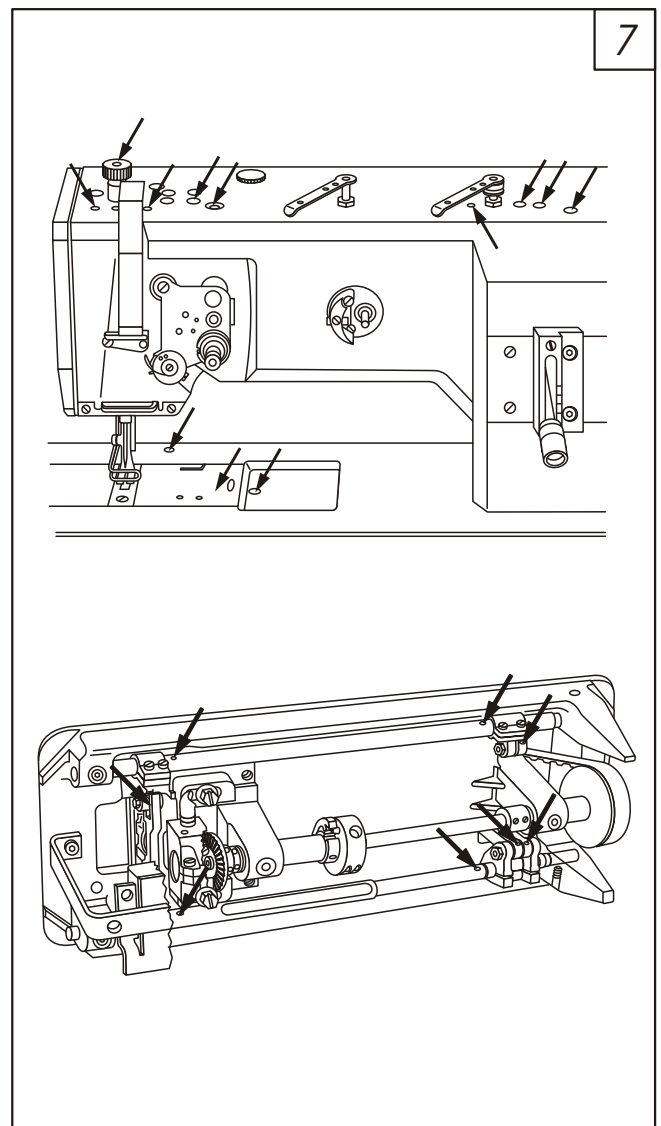
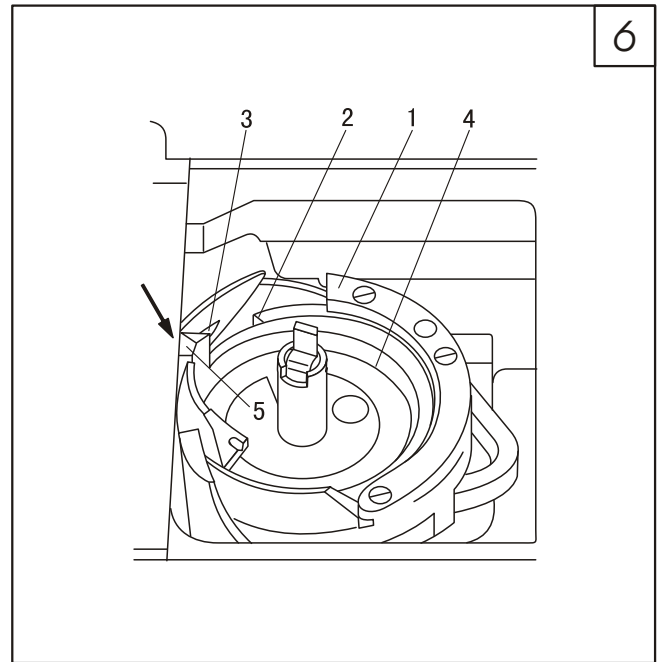

8

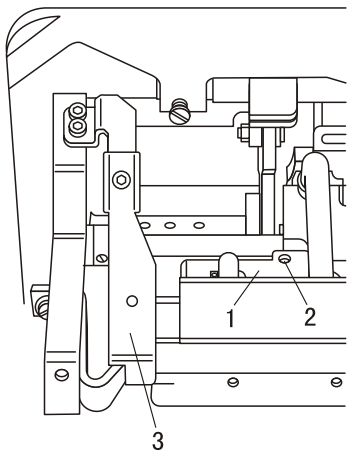

10. Lubricating the hook(Fig.8)

1. Pull out the knee lever, then lay down the machine head;
2. Fill the oil into box 1 through the hole 2 until the oil level exceeds the highest level mark;
3. Raise the machine.

9

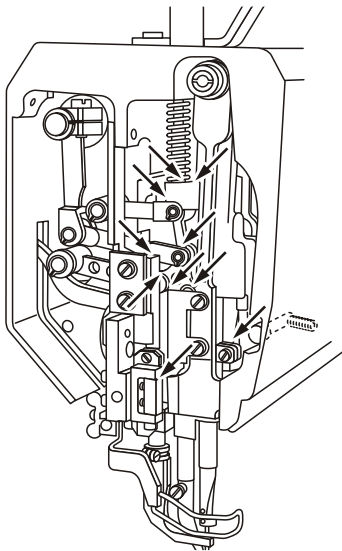

11. Lubricating the machine head (Fig.9)

1. Open the face plate;
2. Oil twice a week at all the moving position as the Fig shows;
3. Close the face plate.

10

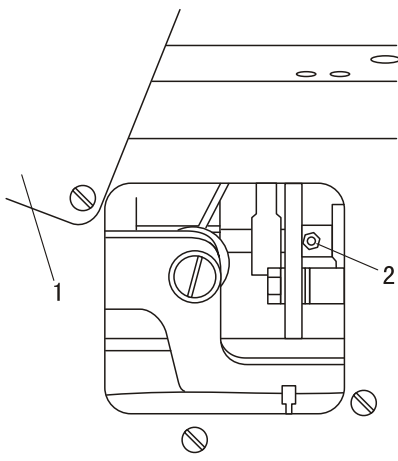

12. Lubricating the upper feed driving eccentric(Fig.10)

1. Open the rear cover 1;
2. Oil the interface (2) at least twice a year; (apply to oil gun)
3. Close the rear cover.

### 13. Adjusting the feed dog

1. Positioning the feed dog across the direction of sewing (Fig.11);
  - a. Loosen the screw 1 and 2;
  - b. Adjust the shaft 3 as required;
  - c. Tighten the screw 1. (Keep the screw 2 loosening for the following adjustment)

※ The bottom feed dog must be the same distance from the left and right side of the needle plate cutout

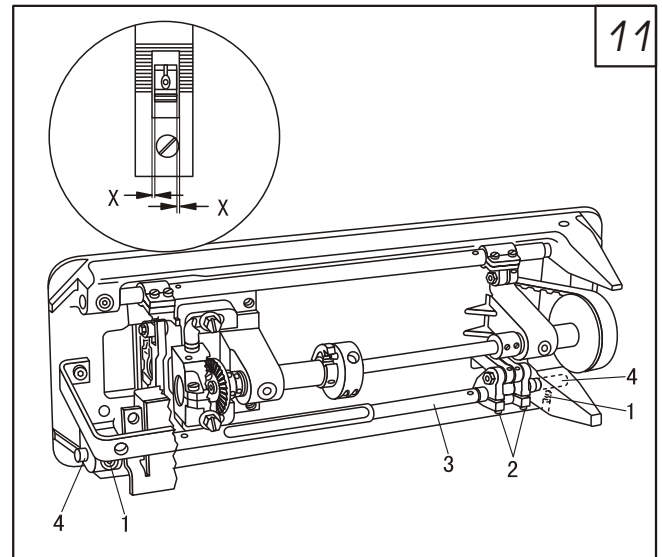

2. Positioning the feed dog in the direction of sewing (Fig. 12)
  - a. Set the longest stitch
  - b. Adjust the shaft 1 as required, and tighten the screw 2.

※ With the longest stitch set, the bottom feed dog must have the same clearance the front and the back with respect to the needle plate cutout when feeding both forwards and backwards.

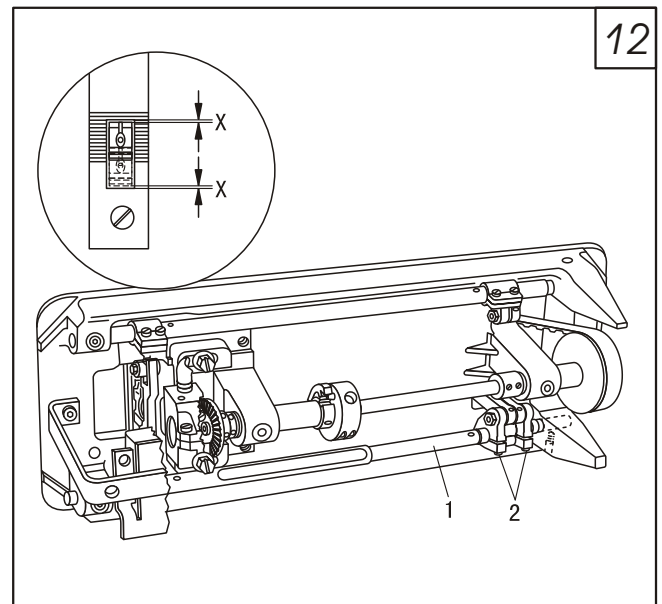

3. Adjusting the height of feed dog (Fig.13)
  - a. Adjust the stitch length to "0" ;
  - b. Turn over the balance wheel until the feed dog reaches its highest position; and as required, adjust the feed dog supporter 1 and the screw 2.

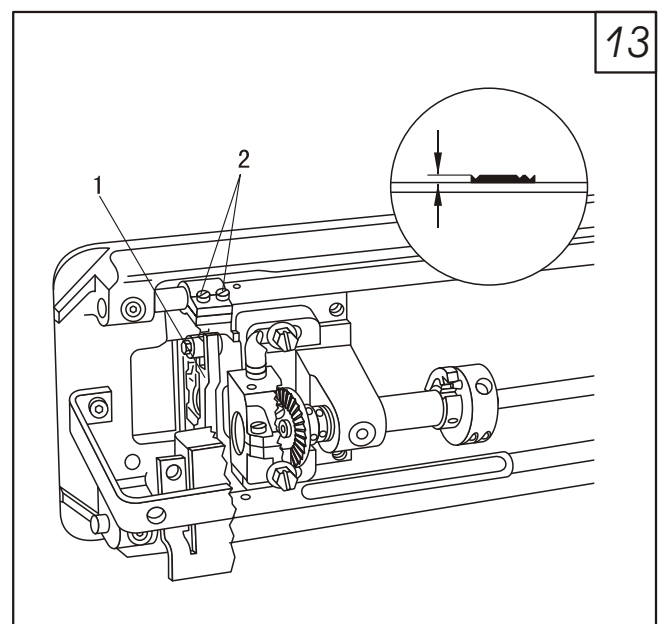



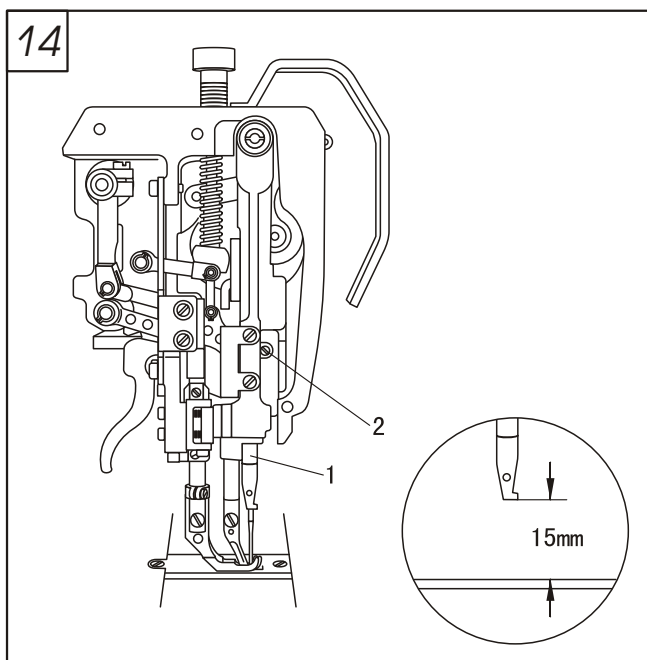

#### 14. Pre-adjusting the needle height(Fig.14)

Move the needle bar 1 (screw 2) up and down, and as required, adjust it to the right position.

※ When the needle bar is at the lowest position, the clearance between needle bar and needle plate should be 15 cm.

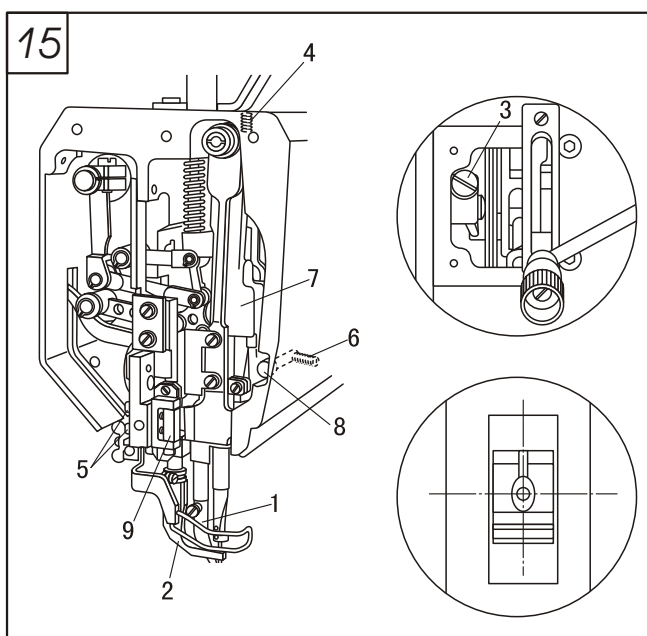

#### 15. Centering the needle in the needle hole(Fig.15)

1. Loosen the walking foot 1 and the presser foot 2;  
2. Adjust the stitch length to “0” , and lift the needle bar to its highest point;

3. Insert the new needle, and loosen the screw 3,4, 5,6;

4. Turn the balance wheel and pass the needle directly through the feed dog;

5. As required, move the needle bar frame 7;

6. Tighten screw 3,4,5,;

7. Move the pin 8 to make it touch the needle bar frame 7, and tighten screw 6.

※ When the stitch length is at the “0” ,the needle must enter the needle hole exactly in the middle

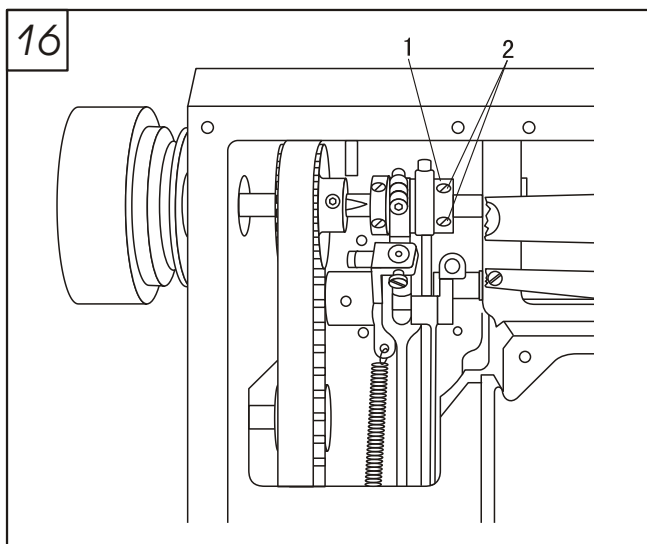

#### 16. Adjusting the bottom feed dog position(Fig.16)

1. Adjust the needle bar to the lowest position;

2. Turn the eccentric wheel 1(screw 2) , and adjust the bottom feed dog to the highest position;

3. Tighten screw 2 to make the eccentric wheel 1 unable to turn;

4. Set the stitch length to the max and turn the eccentric wheel 1 a bit in accordance with requirement 2

5. Tighten screw (2).

※ a. When the needle bar is at its lowest position, the bottom feed dog should be at the highest position;

※ Set the stitch length to its max; turn the balance wheel, and when the bottom feed dog and the needle plate are in the same horizontal level, the point of the needle should be right reaching the surface of the needle plate.

### 17. Adjusting the upper and the lower feed (Fig.17)

1. Adjust the stitch length to the max;
2. Loosen screw 1 to make the feed eccentric wheel 2 turn around the shaft;
3. Adjust the needle bar to the lowest position;
4. Turn the eccentric wheel 2 so that its eccentricity is facing downwards.
5. As required, turn the eccentric wheel a bit as it turns and tighten screw 1;
6. Check it as required.

※ When the stitch length is at the max, the needle bar is at the lowest position, if the reverse feed lever is activated, there will be no feeding.

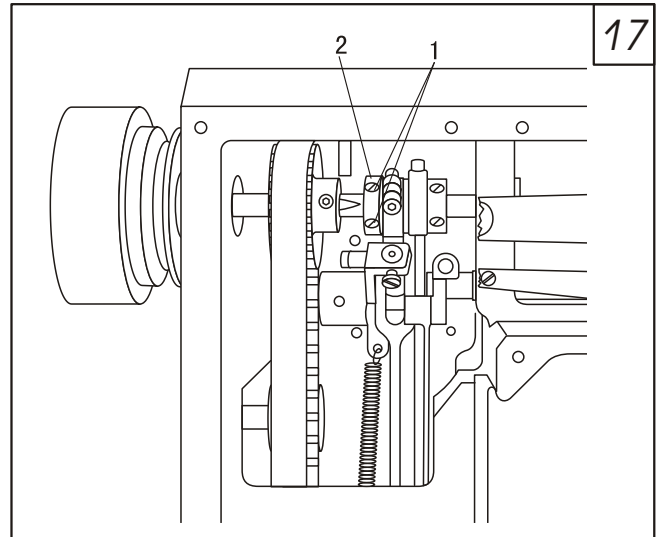

### 18. Position of needle and rotating hook (Fig.18)

1. Adjust the stitch length to “3”, and loosen screw 1,2;
2. The clearance between needle and the hook point should be adjusted to 0.05-0.1 mm by moving the hook gear 4;
3. Tighten screw 1;
4. Turn the needle to the lowest position, and continue to turn the hand wheel to raise 2 mm of the needle;
5. Make the hook point aim at the center of the needle and be sure the guard plate 7 doesn't press on the needle;
6. Leave some gear clearance and tighten screw 2;
7. The vertical clearance between the top of needle eye and the hook point should be 0.8-1 mm by adjusting the needle height;
8. The guard plate 8 might be adjusted to touch the needle lightly.

※ When the stitch length is adjusted to “3” and the needle is lifted 2 mm from the lowest position, the following requirements must be reached:

- a. The clearance between needle and hook point is 0.05-1mm;
- b. The vertical clearance between the top of needle eye and hook point is 0.8-1mm;
- c. The guard plate must touch the needle lightly.

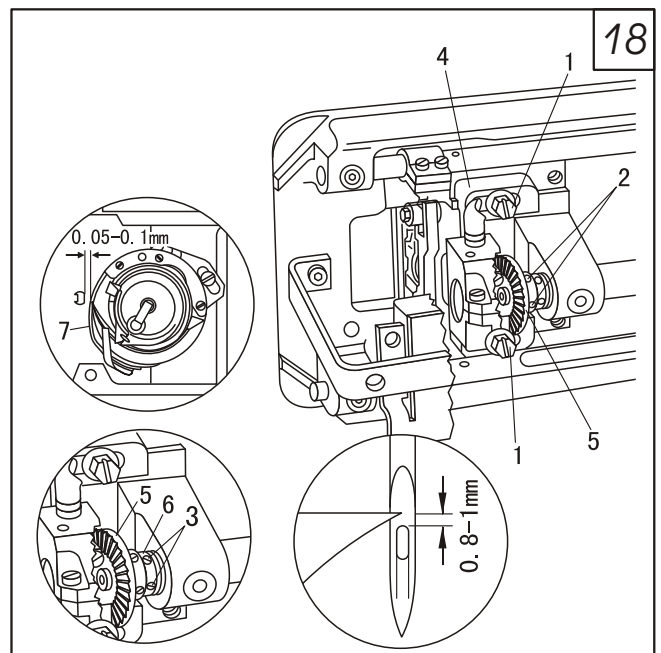

### 19. Adjusting the lifting amount of alternating presser foot (Fig.19)

1. The stitch length is adjusted to “0”, and the lifting amount of alternating presser foot is adjusted to the max;
2. Lower the presser foot 1 on the needle plate;
3. Turn the hand wheel until the walking foot 2 reaches the highest position;
4. As required, move the crank 3 (screw 4);
5. Check as required.

※ When the stitch length is at the “0” and the lifting amount of alternating presser foot is at the max, turn the hand wheel to make sure the clearance between presser foot 1/walking foot 2 and needle plate is 7mm.

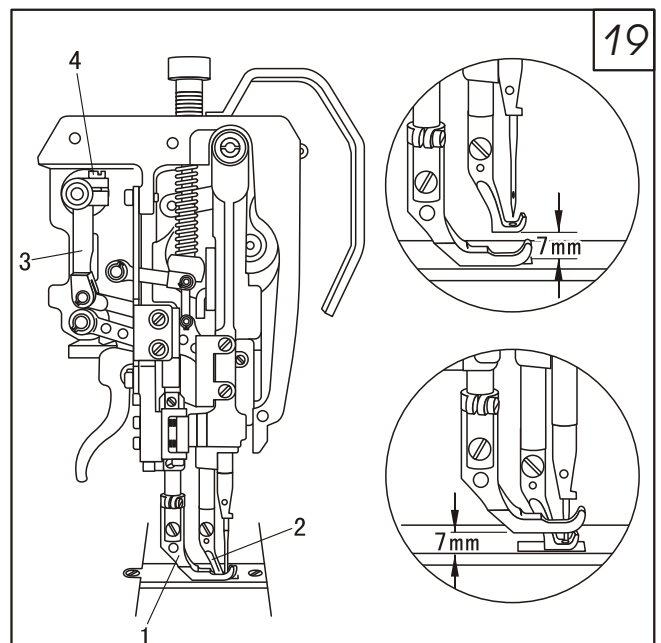

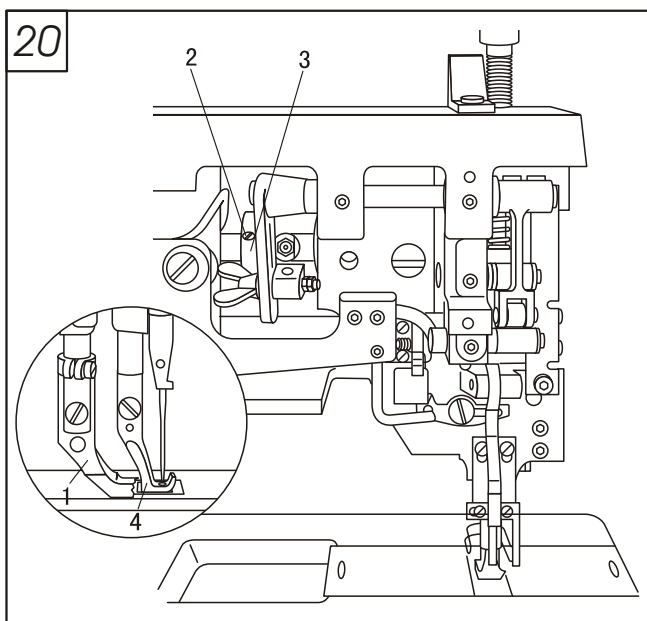

## 20. Top feed adjustment (Fig.20)

1. Lower the presser foot on the needle plate;
  2. Loosen screw 2 until the feed lifting eccentric wheel 3 can turn reluctantly;
  3. Adjust the eccentric wheel 3 as required;
  4. Tighten screw 2;
  5. Check as required.
- ※ When presser foot is resting on the needle plate, the walking foot and the point of needle must both reach the needle plate at the same time when the top feed stroke is set at maximum.

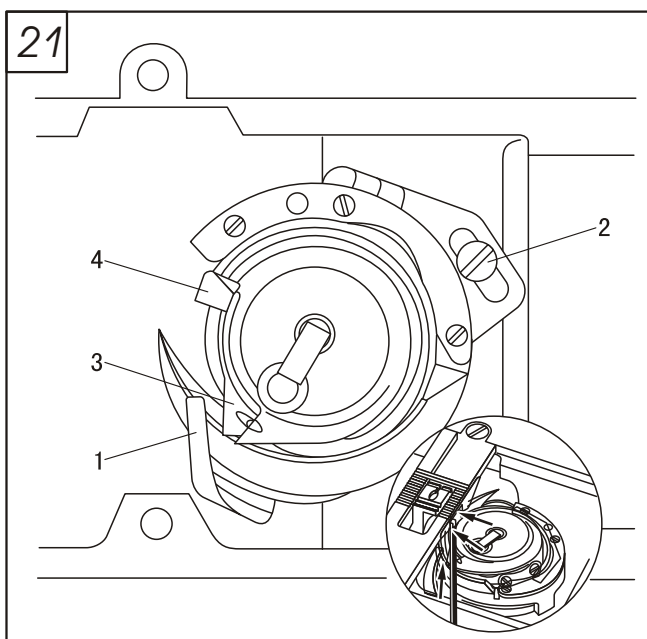

## 21. Adjusting the bobbin case opener

1. Thread the machine; lay down the material; then lower the presser foot;
  2. Turn the hand wheel and sew a bit, then check as required.
  3. Move the opener 1 (screw 2) as required
- ※ The needle thread must not be clamped when passing through the mark 1,3,4

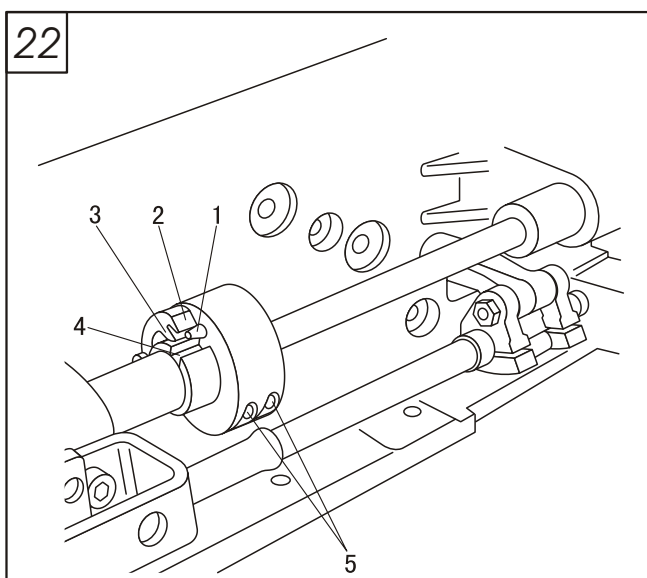

## 22. Safety clutch (Fig.22)

1. When the rotating hook jams the thread, the safety clutch will be off to prevent the hook being damaged
  2. Take out the jammed thread;
- ※ Press the piston 1 and turn the hand wheel until hook 3 of pawl 2 clicks into groove 4

### 23. Needle thread tension release (Fig.23)

When the presser foot is lifted, the clearance between the two tension discs should be 0.5mm (0.5mm is the minimum. When applied to thick thread, it could be adjusted to 1 mm or more). Adjust the plate 1 as required.

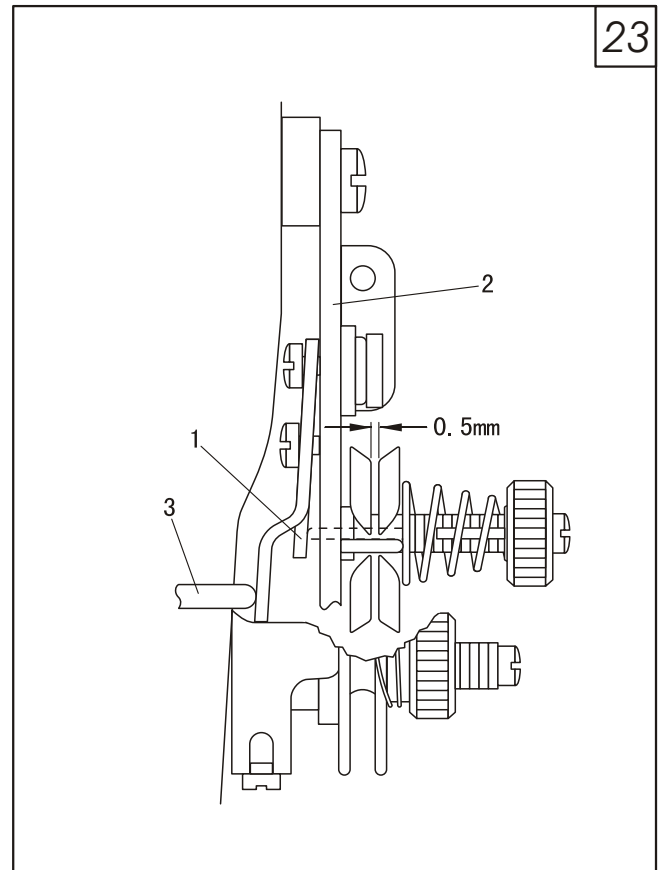

### 24. Bobbin thread winder (Fig.24)

1. When the winder switch on, its spindle must engage reliable; when the winder switch off, the friction wheel 5 and the driving gear 1 should get apart;

2. When the thread level is approx. 1mm from the edge of the bobbin, the winder will switch off automatically;

※ When operating, set the bobbin on the winder, threading the bobbin thread and switch the winder On, adjust the pin 3 and screw 4 as requirements if need.

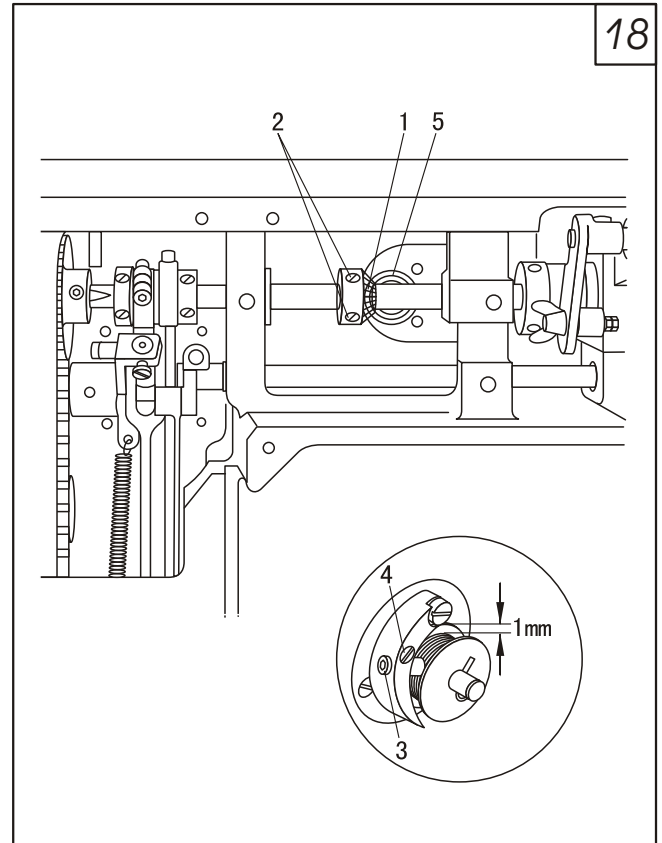

# **PARTS    MANUAL**

# 1. Machine casting components

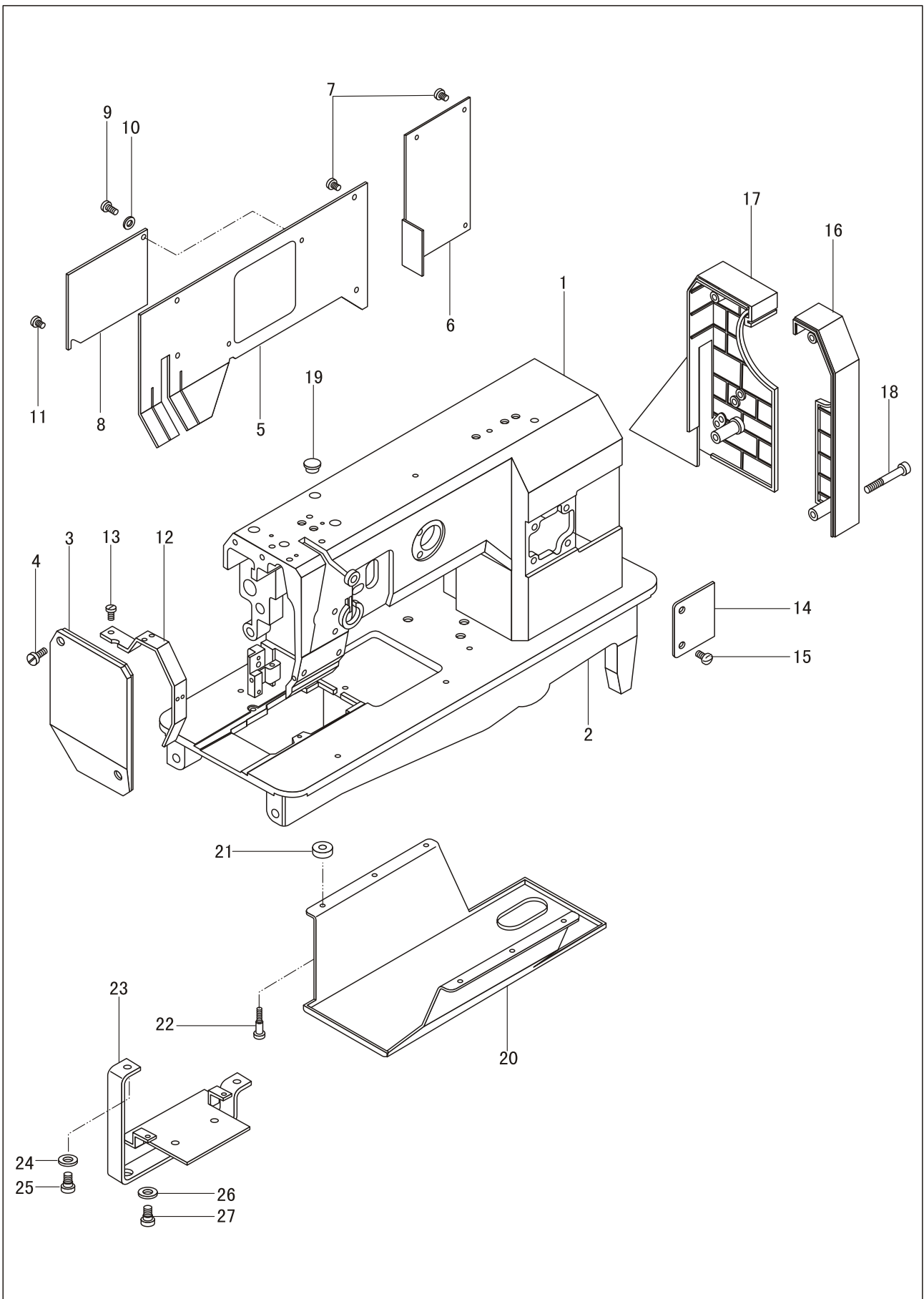

## 1. Machine casting components

No .	Parts No .	Name	Qty.	Remarks
1	71WF2-001	Arm	1	
2	71WF2-002	Bed	1	
3	71WF2-003	Face plate	1	
4		Screw	2	
5	71WF2-004	Rear cover(left)	1	
6	71WF2-005	Rear cover(right)	1	
7		Screw	8	
8	71WF2-006	Cover(small)	1	
9	71WF2-007	Screw(1)	1	
10		Spring	1	
11		Screw(2)	1	GB65-M5 16
12	71WF2-008	Thread take-up lever guard	1	
13		Screw	1	
14	71WF2-009	Front cover	1	GB67-M5 8
15		Screw	2	
16	71WF5-005	Safety guard(1)	1	
17	71WF5-006	Safety guard(2)	1	GB1972-80
18		Set Screw	4	GB67-M4 6
19	71WF2-025	Plug	2	
20	71WF5-007	Oil pan	1	GB67-M5 8
21	71WF5-008	Washer	6	
22		Screw	6	GB67-M5 8
23	71WF2-010	Oil box set bracket complete	1	
24		Washer	2	
25		Screw	2	GB70-85 M5 35
26		Washer	2	
27		Screw	2	

## 2. Needle and presser foot components

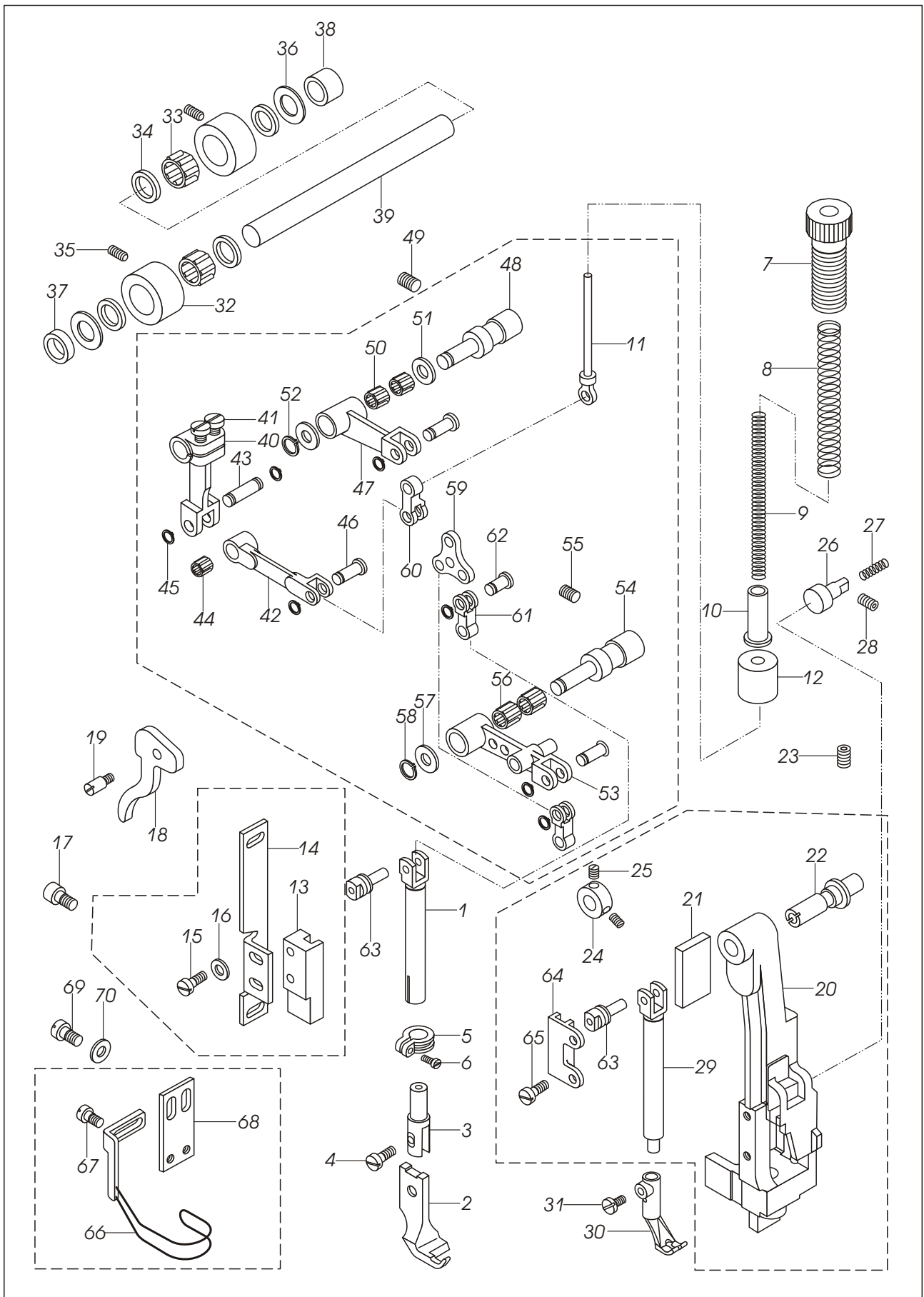



## 2.Needle and presser foot components

No .	Parts No .	Name	Qty.	Remarks
1	71WF4-001	Presser foot bar	1	
2	71WF4-002	Presser foot	1	
3	71WF4-003	Presser foot bracket	1	
4	71WF4-004	Screw	1	
5	71WF4-005	Collar	1	
6	19WF1-013B	Screw	1	
7	71WF4-006	Screw	1	
8	71WF4-007	Spring(big)	1	
9	71WF4-008	Spring(small)	1	
10	71WF4-009	Spring bushing	1	
11	71WF4-010	Guide bar	1	
12	71WF4-011	Oil felt	1	
13	71WF4-012	Sliding guide	1	
14	71WF4-013	Set plate	1	M15 1
15		Screw	2	
16		Washer	2	
17		Screw	2	
18	71WF4-014	Presser foot lifting bar	1	
19	71WF4-015	Lifting bar shaft	1	
20	71WF3-003	Needle bar rocking frame	1	
21	71WF3-004	Oil felt	1	
22	71WF3-005	Hinge pin	1	GB65-M4 10
23		Screw	1	GB97.1-4
24	71WF3-006	Collar	1	GB70-M5 10
25	13WF1-029	Screw	2	
26	71WF3-007	Pin	1	
27	71WF3-008	Spring	1	
28		Screw	1	
29	71WF3-015	Walking foot bar	1	
30	71WF3-016	Walking foot	1	GB77-M6 8
31	71WF3-017	Screw	1	
32	71WF3-018	Upper feed bushing	2	M3 3
33		Bearing	2	
34	71WF3-019	Stop ring	4	
35		Screw	2	GB77-M5 8
36	71WF3-020	Washer	2	
37	71WF3-021	Washer(front)	1	
38	71WF3-022	Washer(rear)	1	SM17/64" 28
39	71WF3-023	Upper feed shaft	1	
40	71WF3-024	Upper feed crank(I)	1	10 13 9.7
				GB77-M6 5

## 2. Needle and presser foot components

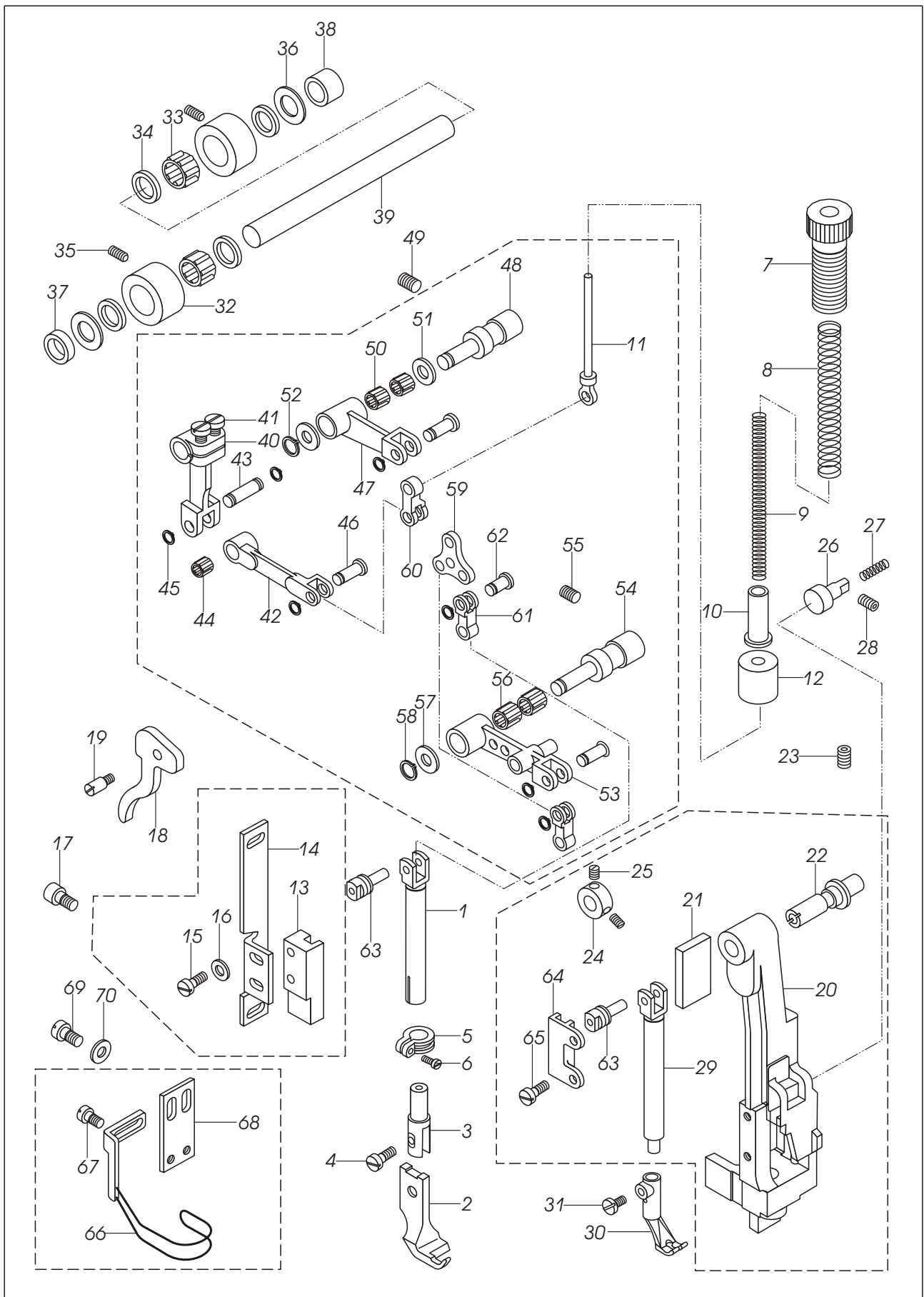

## 2.Needle and presser foot components

No .	Parts No .	Name	Qty.	Remarks
41		Screw	2	
42	71WF3-025	Presser foot lifting link	1	
43	71WF3-026	Link pin	1	
44		Bearing	1	
45		Spring	6	
46	71WF3-027	Pin(long)	3	
47	71WF3-028	Upper feed crank(II)	1	
48	71WF3-029	Shaft	1	
49		Screw	1	GB65-M5 12
50		Bearing	2	
51	71WF3-030	Washer	2	5 8 7.7
52		Spring	1	GB894.1-5
53	71WF3-031	Upper feed crank(III)	1	
54	71WF3-032	Shaft	1	
55		Screw	1	
56		Bearing	2	GB77-M6 8
57	71WF3-033	Washer	1	6 9 7.7
58	71WF3-034	Spring	1	
59	71WF3-035	Movable plate	1	GB894.1-6
60	71WF3-036	Link	1	
61	71WF3-037	Presser foot link	2	
62	71WF3-038	Pin(short)	1	GB77-M6 8
63	71WF3-039	Slide block	1	7 10 7.5
64		Sliding guide	1	
65	71WF2-022	Screw	2	GB894.1-7
66	71WF2-023	Finger guard	1	
67	71WF2-024	Screw	2	
68		Finger guard set plate	1	
69		Screw	2	
70		Washer	2	

### 3.Presser foot lifting components

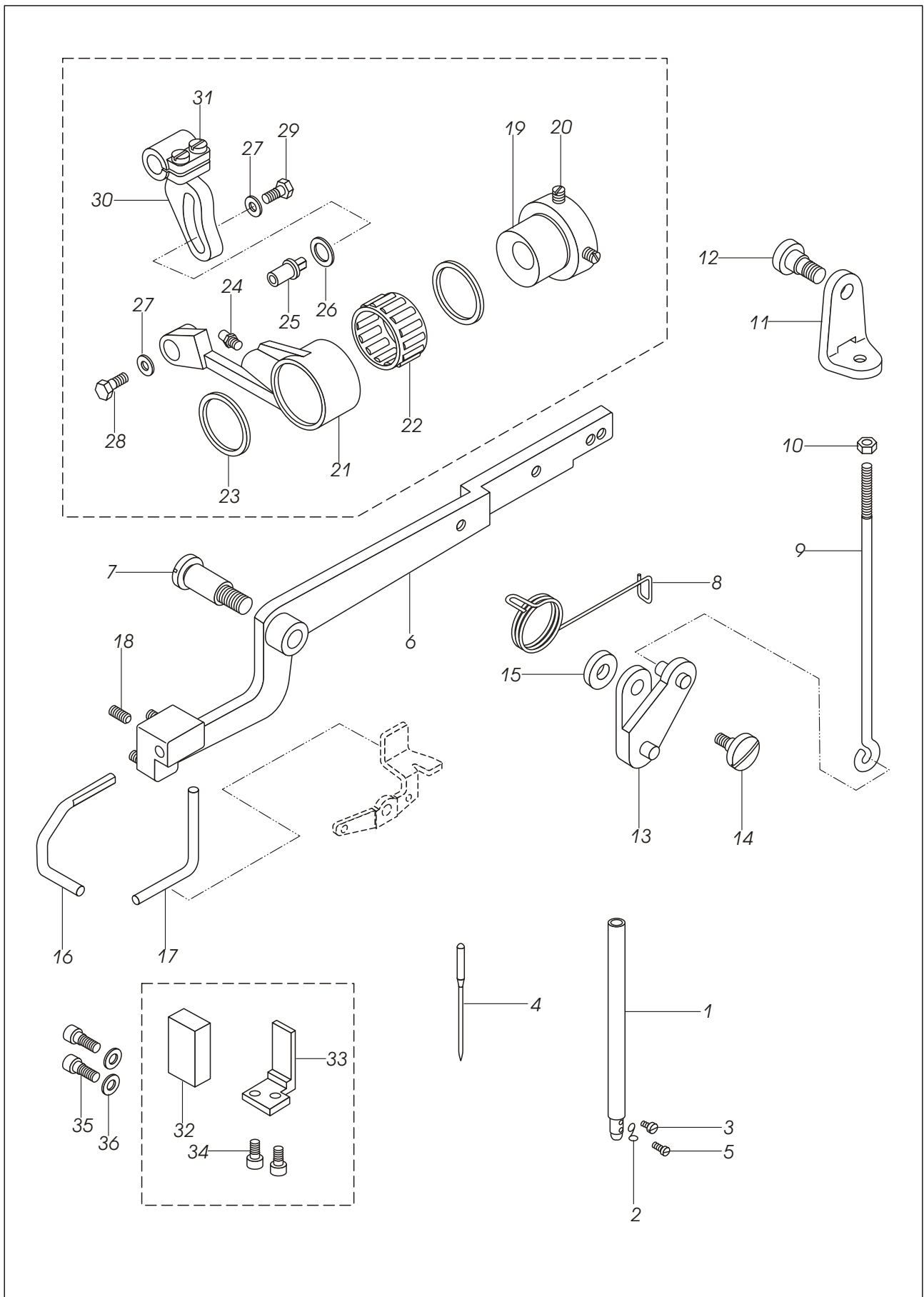

### 3.Presser foot lifting components

No .	Parts No .	Name	Qty.	Remarks
1	71WF1-001	Needle bar	1	
2	71WF1-002	Needle bar thread guide	1	
3	13WF1-015	Screw	1	
4		Needle	1	
5	71WF1-003	Screw	1	
6	71WF4-016	Knee lifter lever	1	
7	71WF4-017	Screw	1	
8	71WF4-018	Spring	1	
9	71WF4-019	Knee lifter drawing bar	1	
10		Nut	1	M3 5
11	71WF4-020	Connector	1	DP 35 LR
12	71WF4-021	Screw	1	M3 5
13	71WF4-022	Movable plate complete	1	
14	71WF4-023	Screw	1	
15	71WF4-024	Washer	1	
16	71WF4-039	Presser foot lift bent bar	1	
17	71WF4-040	Releasing bent bar	1	GB6170-M5
18		Screw	3	
19	71WF3-040	Presser foot lift cam	1	
20	13WF1-018	Screw	2	
21	71WF3-041	Link	1	
22		Bearing	1	
23	71WF3-042	Stop ring	2	
24		Oil cup	1	
25	71WF3-043	Pin	1	
26	71WF3-044	Washer	1	
27	71WF3-045	Washer	2	M6 0.75
28		Screw(front)	1	
29		Screw(rear)	1	22 26 12.6
30	71WF3-046	Adjusting crank	1	
31		Screw	2	GB1152-89 M6
32	71WF3-083	Block	1	
33	71WF3-084	Set bracket	1	
34		Screw	2	
35		Screw	2	GB5781-M5 8
36		Washer	2	GB5781-M5 10

#### 4.Thread take-up and thread tension components

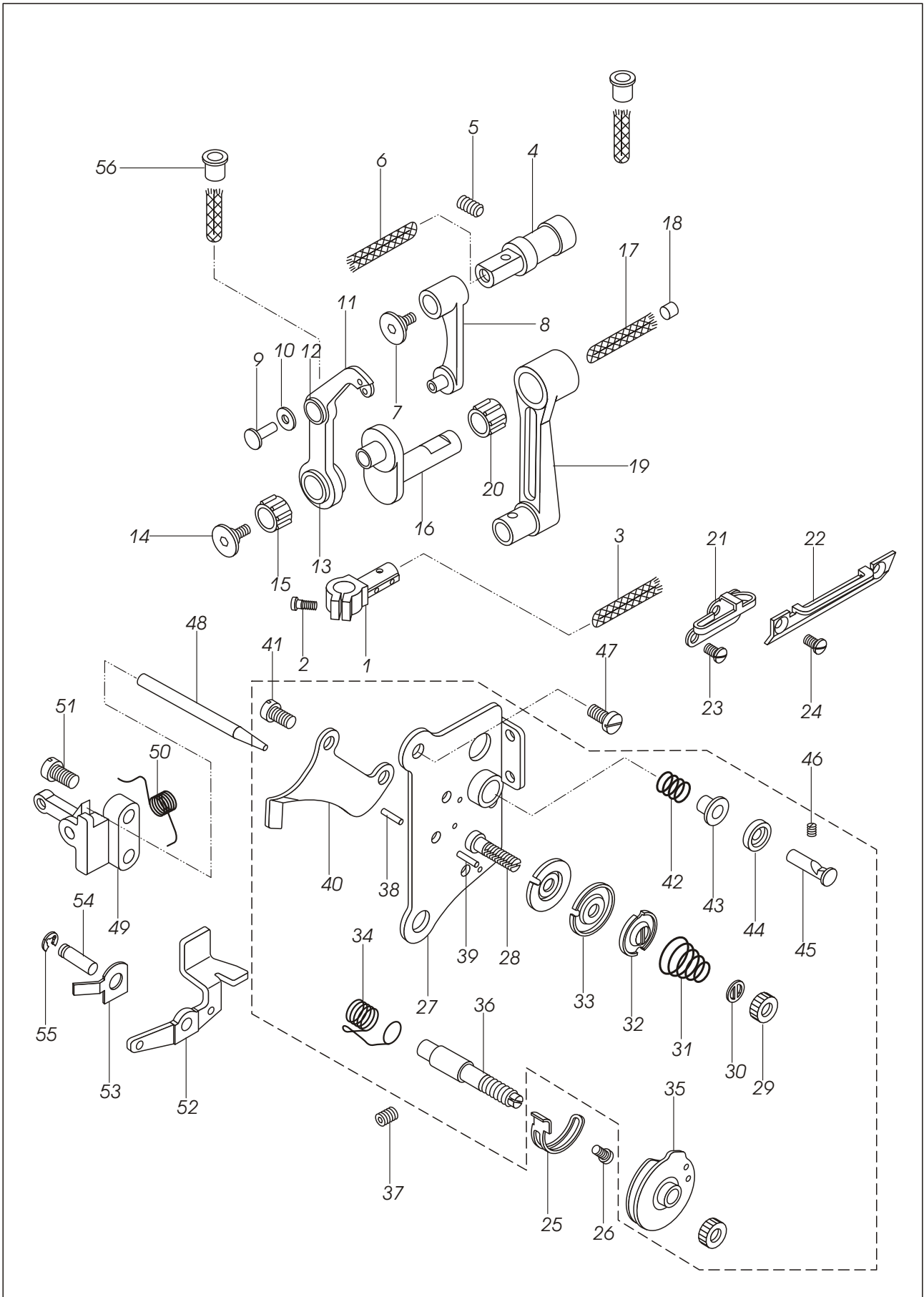

#### 4.Thread take-up and thread tension components

No .	Parts No .	Name	Qty.	Remarks
1	71WF1-004	Needle bar connector	1	
2	71WF1-005	Screw	1	
3		Oil wick	1	
4	71WF1-006	Pin shaft	1	
5		Screw	1	
6		Oil wick	1	
7	71WF1-007	Screw	1	
8	71WF1-008A	Crank	1	
9	71WF1-008B	Stud	1	M4 10
10	71WF1-008C	Washer	1	
11	71WF1-008D	Thread take-up lever	1	
12	71WF1-008E	Link bushing	1	GB77-M6 8
13	71WF1-008F	Bearing bushing	1	
14	71WF1-007	Screw	1	
15		Bearing	1	
16	71WF1-009	Hinge shaft	1	
17		Oil wick	1	
18	71WF1-010	Plug	1	
19	71WF1-011	Needle bar link	1	
20		Bearing	1	
21	71WF2-011	Thread guide(middle)	1	
22	71WF2-012	Thread guide(lower)	1	7 10 7.5
23	71WF2-013	Screw	1	
24		Screw	1	
25	71WF2-016	Stop plate	1	
26		Screw	1	
27	71WF2-021A	Set plate	1	9 12 12.7
28	71WF2-021B	Bolt	1	
29	71WF2-021C	Nut	2	
30	71WF2-021D	Stop washer	1	M5 7
31	71WF2-021E	Spring	1	GB68-M4 8
32	71WF2-021F	Thread releasing disc	1	
33	71WF2-021G	Thread tension disc	2	GB65-M4 6
34	71WF2-021H	Thread take-up spring	1	
35	71WF2-021I	Thread control plate assembly	1	
36	71WF2-021J	Bolt	1	
37		Screw	1	
38	71WF2-021K	Thread guide pin	2	
39	71WF2-021L	Thread releasing pin	1	
40	71WF2-021M	Thread releasing plate	1	
41	71WF2-021N	Screw	2	
42	71WF2-021O	Spring	1	
43	71WF2-021P	Thread tension cap	1	
44	71WF2-021Q	Thread tension disc	1	GB77-M5 8
45	71WF2-021R	Pin	1	
46		Screw	1	
47		Thread releasing bracket assembly	1	
48	71WF2-022	Thread releasing bar	1	SM9/64" 40
49	71WF4-033		1	
50	71WF4-034	Spring	1	
51	71WF4-035	Screw	2	
52	71WF4-036	Thread releasing lever	1	
53	71WF4-037	Spring plate	1	GB73-M4 8
54	71WF3-053	Lever stud	1	GB67-M4 10
55		Split ring	1	
56	71WF2-026	Oil pipe	2	

## 5.Feed adjustment components

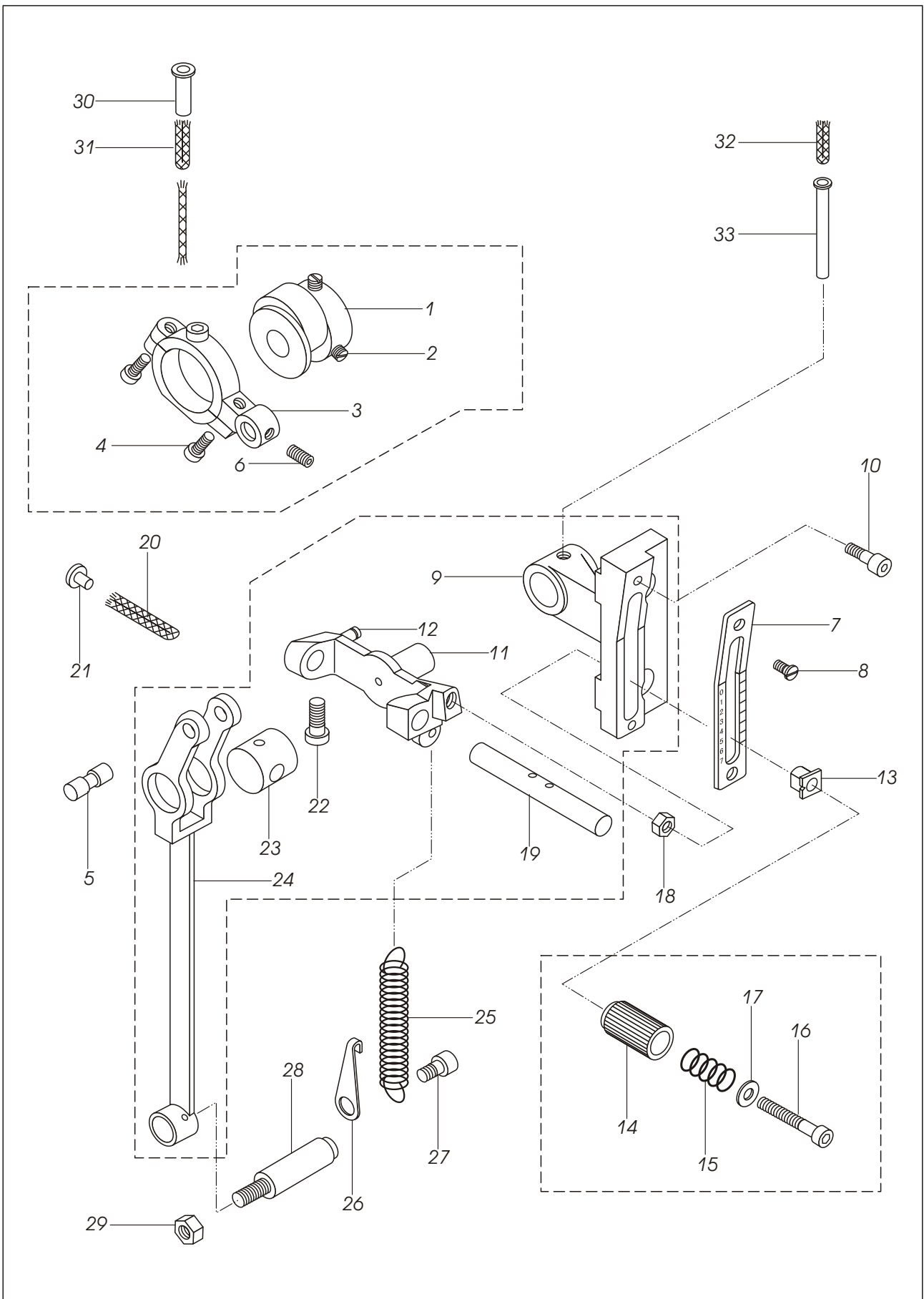



## 5.Feed adjustment components

No .	Parts No .	Name	Qty.	Remarks
1	71WF3-047	Feed cam	1	
2	22T2-005B3	Screw	2	
3	71WF3-048	Feed crank	1	
4		Screw	2	
5	71WF3-049	Link stud	1	
6		Screw	1	
7	71WF3-050	Stitch length label	1	
8		Screw	2	
9	71WF3-051	Stitch length bracket	1	SM1/4" 40
10		Screw	2	
11	71WF3-052	Stitch length adjusting bracket	1	GB70-M5 12
12	71WF3-053	Stud	1	
13	71WF3-054	Stop bushing	1	GB77-M4 5
14	71WF3-055	Adjusting bar	1	
15	71WF3-056	Spring	1	GB68-M3 8
16	71WF3-057	Screw	1	
17	71WF3-058	Washer	1	GB70-M6 16
18		Nut	1	
19	71WF3-059	Sliding shaft	1	
20		Oil wick	1	
21	71WF1-013	Filter	1	
22	71WF3-060	Screw	1	
23	71WF3-061	Sliding guide	1	
24	71WF3-062	Link	1	
25	71WF3-063	Spring	1	GB6172-86 M6
26	71WF3-064	Spring hook	1	
27		Screw	1	
28	71WF3-013	Crank stud	1	
29	71WF3-014	Nut	1	
30	71WF2-027	Oil tube		
31		Oil wick		
32	71WF2-028	Oil tube		
33		Oil wick		
				GB70-85 M6 10
				SM17/64" 28

## 6. Upper shaft and rocking shaft components

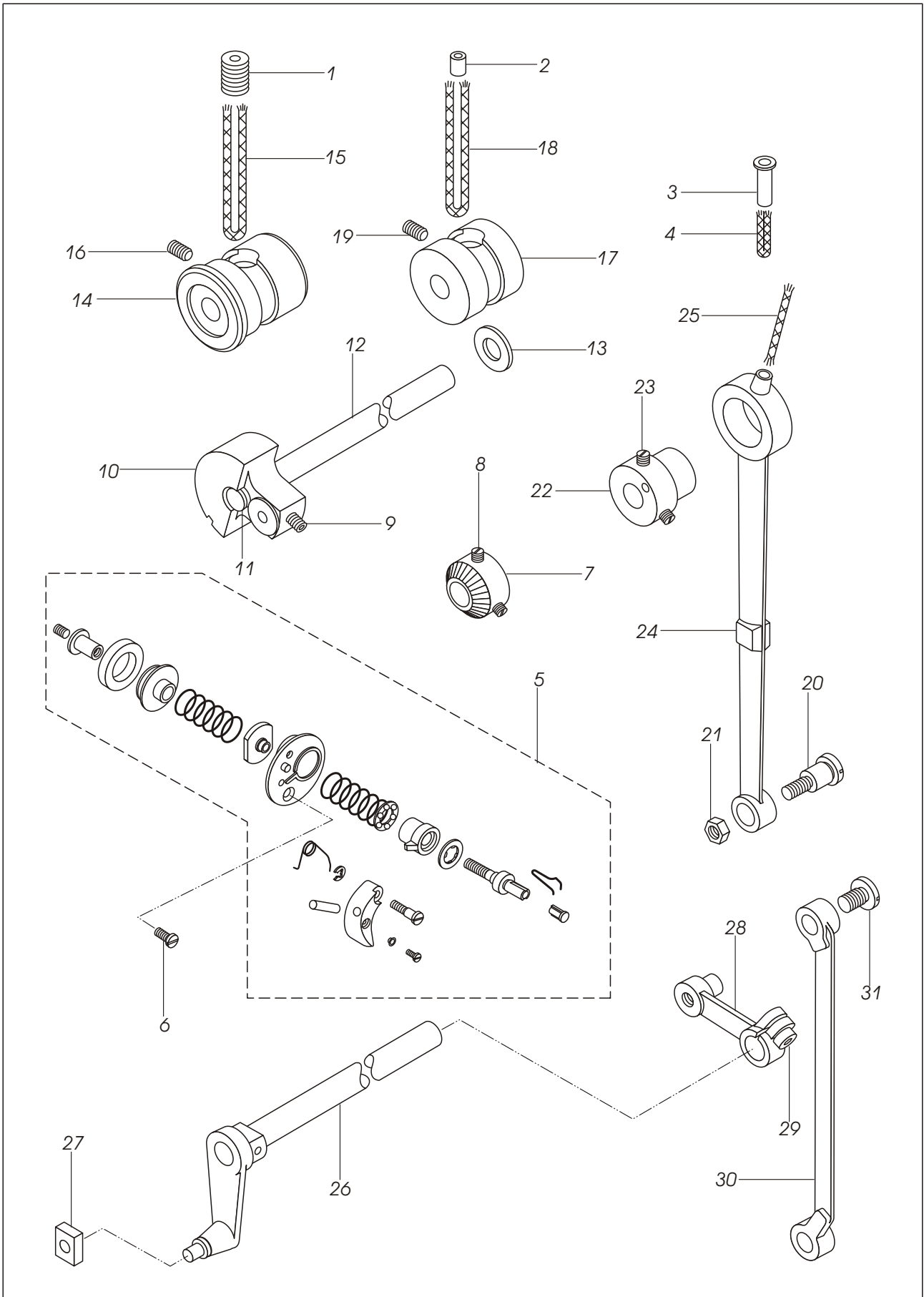

## 6.Upper shaft and rocking shaft components

No .	Parts No .	Name	Qty.	Remarks
1	71WF2-029	Oil plug	1	
2	71WF2-030	Oil plug	1	
3	71WF2-027	Oil pipe	1	
4		Oil wick	1	
5	71WF2-034	Bobbin thread winder assembly	1	
6		Screw	1	
7	71WF2-035	Friction wheel	1	
8	13WF1-027	Screw	2	
9		Screw	2	
10	71WF1-012	Needle bar crank	1	
11	71WF1-013	Oil plug	1	
12	71WF1-014	Upper shaft	1	
13	71WF1-015	Washer	1	GB68-M4 8
14	71WF1-016	Upper shaft bushing(front)	1	
15		Oil wick	1	M6 0.75
16		Screw	1	GB77-M6 5
17	71WF1-017	Upper shaft bushing(middle)	1	
18		Oil wick	1	
19		Screw	1	
20	71WF3-078	Screw	1	
21	71WF3-079	Nut	1	
22	71WF3-080	Feed dog lift cam	1	
23	71WF3-081	Screw	2	GB77-M6 8
24	71WF3-082	Feed dog lift link	1	
25		Oil wick	1	
26	71WF3-001	Rocking shaft assembly	1	GB77-M6 8
27	71WF3-002	Slide block	1	
28	71WF3-009	Rocking shaft driving cam	1	SM11/64" 28
29		Screw	1	
30	71WF3-010	Rocking shaft link	1	
31	71WF3-011	Screw	1	
				GB70-M8 16

## 7. Timing belt components

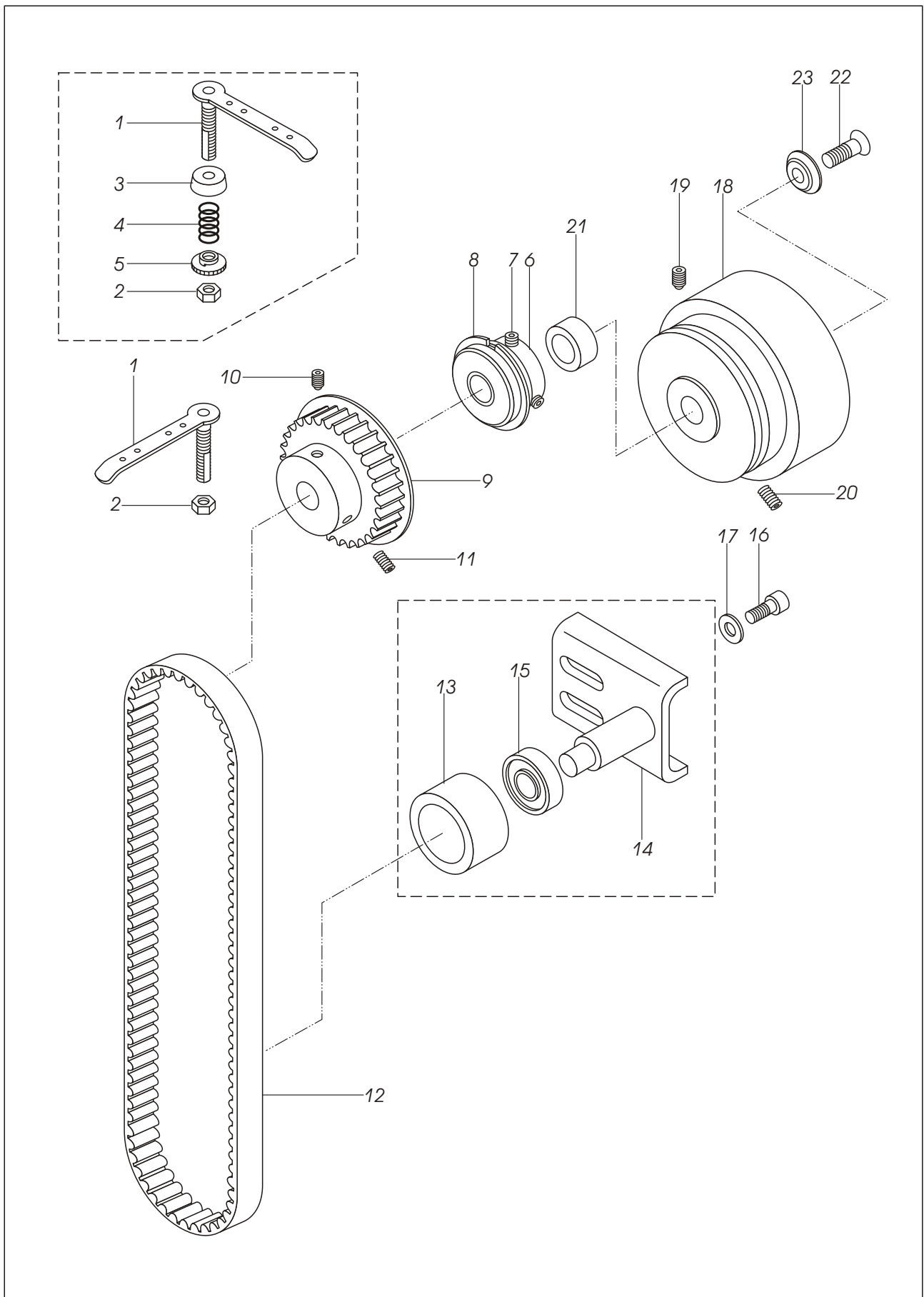

## 7. Timing belt components

No .	Parts No .	Name	Qty.	Remarks
1	71WF2-014	Thread guide bar assembly	1	
2		Nut	1	
3	71WF2-015A	Thread tension disc	1	
4	71WF2-015B	Thread tension spring	1	
5	71WF2-015C	Thread tension nut	1	
6	71WF1-018	Collar	1	
7	19WF3-005	Screw	2	
8		Bearing	1	
9	71WF1-019	Timing pulley assembly	1	GB6170-M6
10		Screw	1	
11		Screw	1	
12		Timing belt	1	
13	71WF1-021A	Tension wheel	1	
14	71WF1-021B	Tension wheel bracket	1	M6 0.75
15		Bearing	1	6002-2ZNR15 32 9
16		Screw	2	
17		Washer	2	GB78-M6 0.75
18	71WF1-022	Hand wheel	1	GB77-M6 0.75
19		Screw	1	270H063
20		Screw	1	
21	71WF1-023	Collar	1	
22		Screw	1	6000-2Z
23	71WF1-024	Washer	1	GB70-M5 12 GB97.1-5  GB78-M6 0.75 GB77-M6 0.75  GB68-M6 20

# 8. Rotating hook saddle components

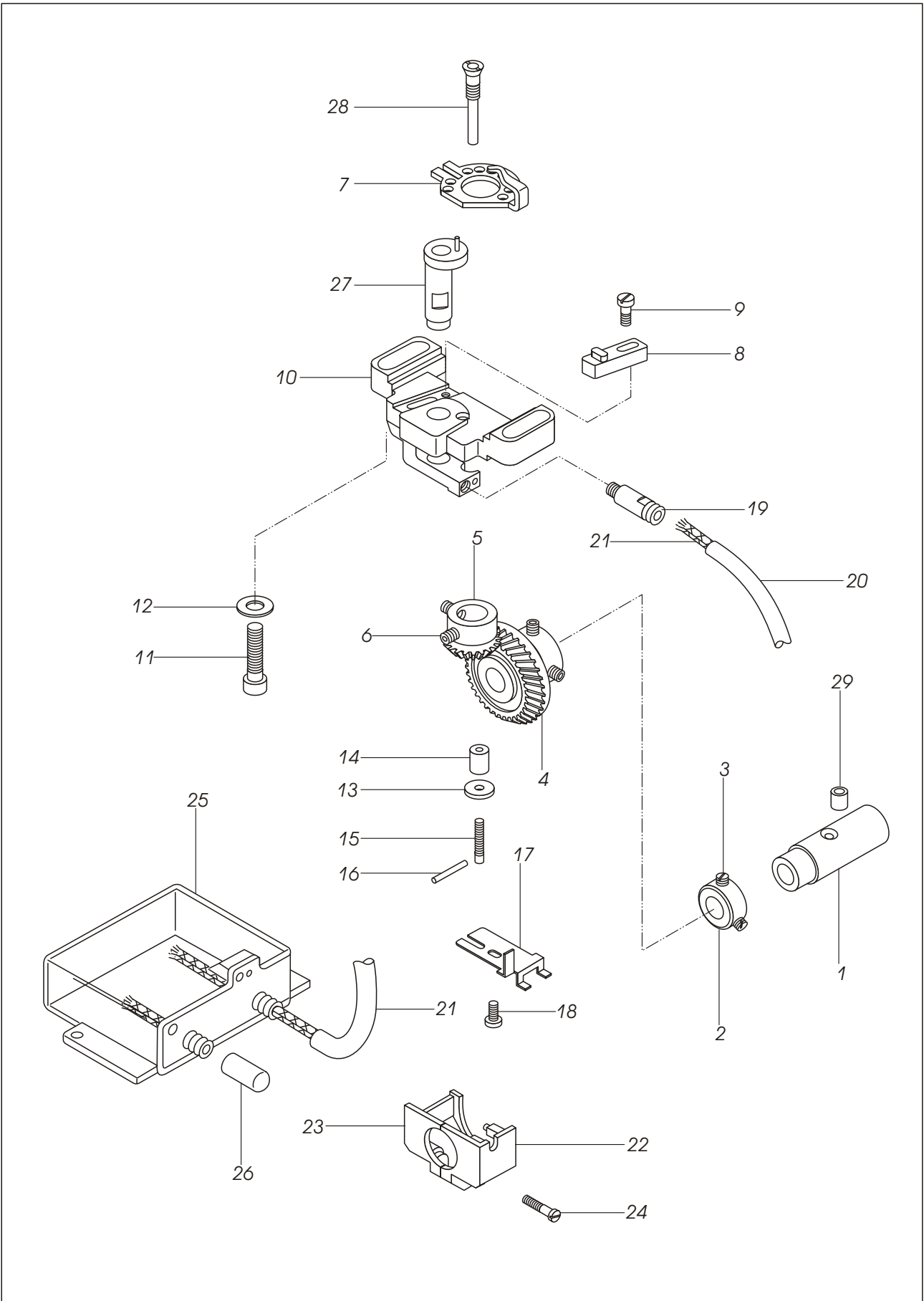

## 8. Rotating hook saddle components

No .	Parts No .	Name	Qty.	Remarks
1	71WF1-028	Lower shaft bushing(front)	1	
2	71WF1-031	Collar	1	
3	22WF4-005	Screw	2	
4	71WF1-032	Lower shaft gear	1	
5	71WF1-033	Rotating hook gear	1	
6	19WF3-005	Screw	4	
7	71WF1-034	Hook opener	1	
8	71WF1-035	Adjusting plate assembly	1	
9		Adjusting screw	1	
10	71WF1-036	Rotating hook saddle	1	M5
11		Screw	2	
12	71WF1-037	Washer	2	
13	71WF1-038	Oil felt(1)	1	M6 0.75
14	71WF1-039	Oil felt(2)	1	
15	71WF1-040	Screw bar	1	
16		Pin	1	GB65-M4 8
17	71WF1-041	Cover plate	1	
18		Screw	1	GB70-85 M6 25
19	71WF1-042	Joint	1	
20	71WF1-043	Oil pipe	1	
21		Oil wick	1	
22	71WF1-044	Gear cover(1)	1	
23	71WF1-045	Gear cover(2)	1	GB879-86 1 16
24		Screw	1	
25	71WF1-047	Oil box	1	GB65-M4 8
26	71WF1-049	Oil hole cover	1	
27	71WF1-061	Rotating hook shaft	1	
28	71WF1-062	Screw	1	3 L=400
29	71WF2-030	Oil plug	1	GB65-M4 14

## 9. Needle plate and hook components

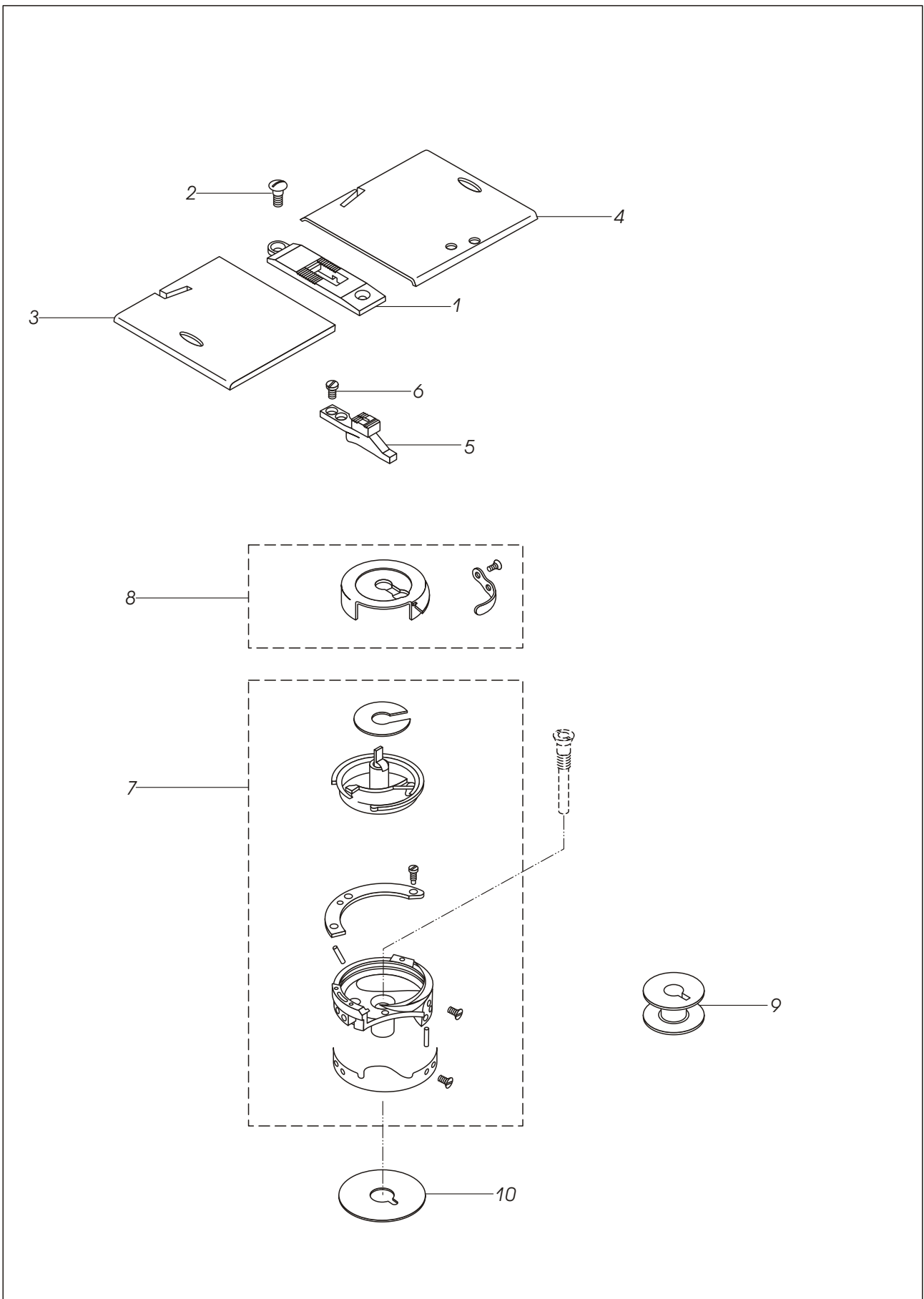



## 9. Needle plate and hook components

No .	Parts No .	Name	Qty.	Remarks
1	71WF2-017	Needle plate	1	
2	71WF2-018	Screw	2	
3	71WF2-019	Slide plate(left)	1	
4	71WF2-020	Slide plate(right)	1	
5	71WF3-070	Feed dog	1	
6	JO.O.50	Screw	2	
7		Rotating hook assembly	1	
8		Bobbin cap	1	
9	71WF1-046	Bobbin	1	SM11/64" 40
10	71WF1-060	Washer	1	
				SM1/8" 44
				LRT1242-R
				SCP545

# 10. Lower feed components

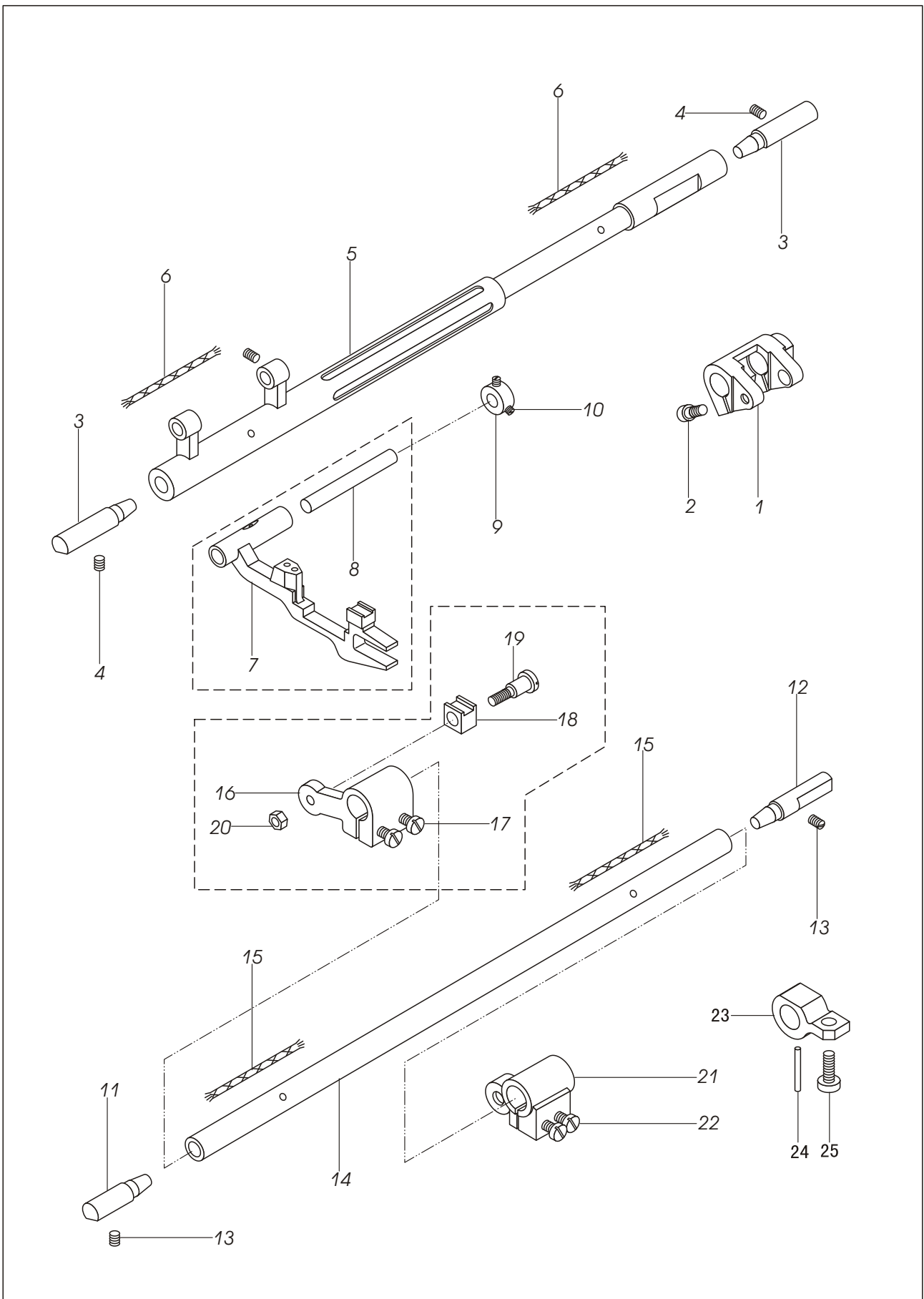

## 10. Lower feed components

No .	Parts No .	Name	Qty.	Remarks
1	71WF3-012	Feed shaft crank	1	
2		Screw	2	
3	71WF3-065	Feed shaft set pin	2	
4		Screw	2	
5	71WF3-066	Feed shaft	1	
6		Oil wick	2	
7	71WF3-067	Feed dog supporter	1	
8	71WF3-068	Hinge pin	1	GB65-M5 10
9	71WF3-069	Collar	1	
10		Screw Feed dog lifting shaft set pin(front)	2	GB77-M6 8
11	71WF3-071	Feed dog lifting shaft set pin(rear)	1	
12	71WF3-065		1	
13		Screw	2	
14	71WF3-072	Feed dog lifting shaft	1	
15		Oil wick	2	
16	71WF3-073	Feed dog lifting cam	1	GB77-M5 4
17		Screw	2	
18	71WF3-074	Slide block	1	
19	71WF3-075	Screw	1	GB77-M6 8
20	71WF3-076	Nut	1	
21	71WF3-077	Feed dog lifting shaft crank	1	
22		Screw	2	
23	77WF7-005	Crank	1	GB65-M5 12
24	77WF7-006	Pin	1	
25		Screw	1	SM11/64" 32

# 11. Lower shaft components

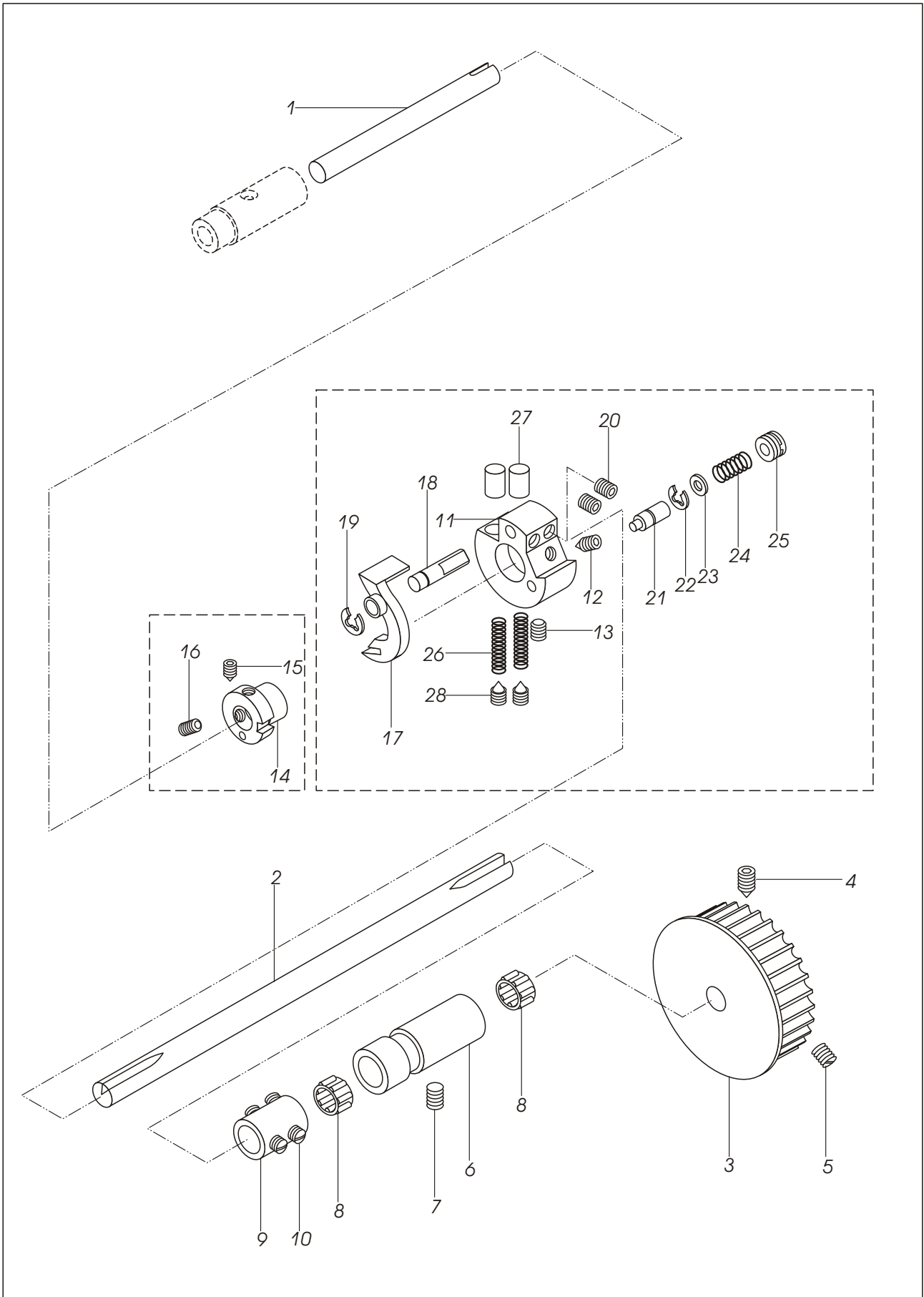

## 11. Lower shaft components

No .	Parts No .	Name	Qty.	Remarks
1	71WF1-025	Lower shaft(front)	1	
2	71WF1-026	Lower shaft(rear)	1	
3	71WF1-027	Timing pulley assembly	1	
4		Screw	1	
5		Screw	1	
6	71WF1-029	Lower shaft bushing(rear)	1	
7		Screw	1	
8		Bearing	2	
9	71WF1-030	Collar	1	
10	13WF1-027	Screw	4	
11	71WF1-050	Safety clutch body	1	GB78-M6 0.75
12		Screw	1	GB77-M6 0.75
13		Screw	1	
14	71WF1-051	Safety clutch cam	1	GB77-M6 8
15		Screw	1	10 13 9.7
16		Screw	1	
17	71WF1-052	Spring plate	1	
18	71WF1-053	Pin	1	
19		Split ring	1	GB78-M6 0.75
20		Screw	2	GB77-M6 0.75
21	71WF1-054	Stop pin	1	
22		Split ring	1	GB78-M6 0.75
23	71WF1-055	Washer	1	GB77-M6 0.75
24	71WF1-056	Spring	1	
25	71WF1-057	Screw	1	
26	71WF1-058	Spring	2	GB896-86 4
27	71WF1-059	Spring bushing	2	GB77-M5 6
28		Screw	2	GB896-86 3
				GB78-M6 0.75

## 12. Knee lifter components

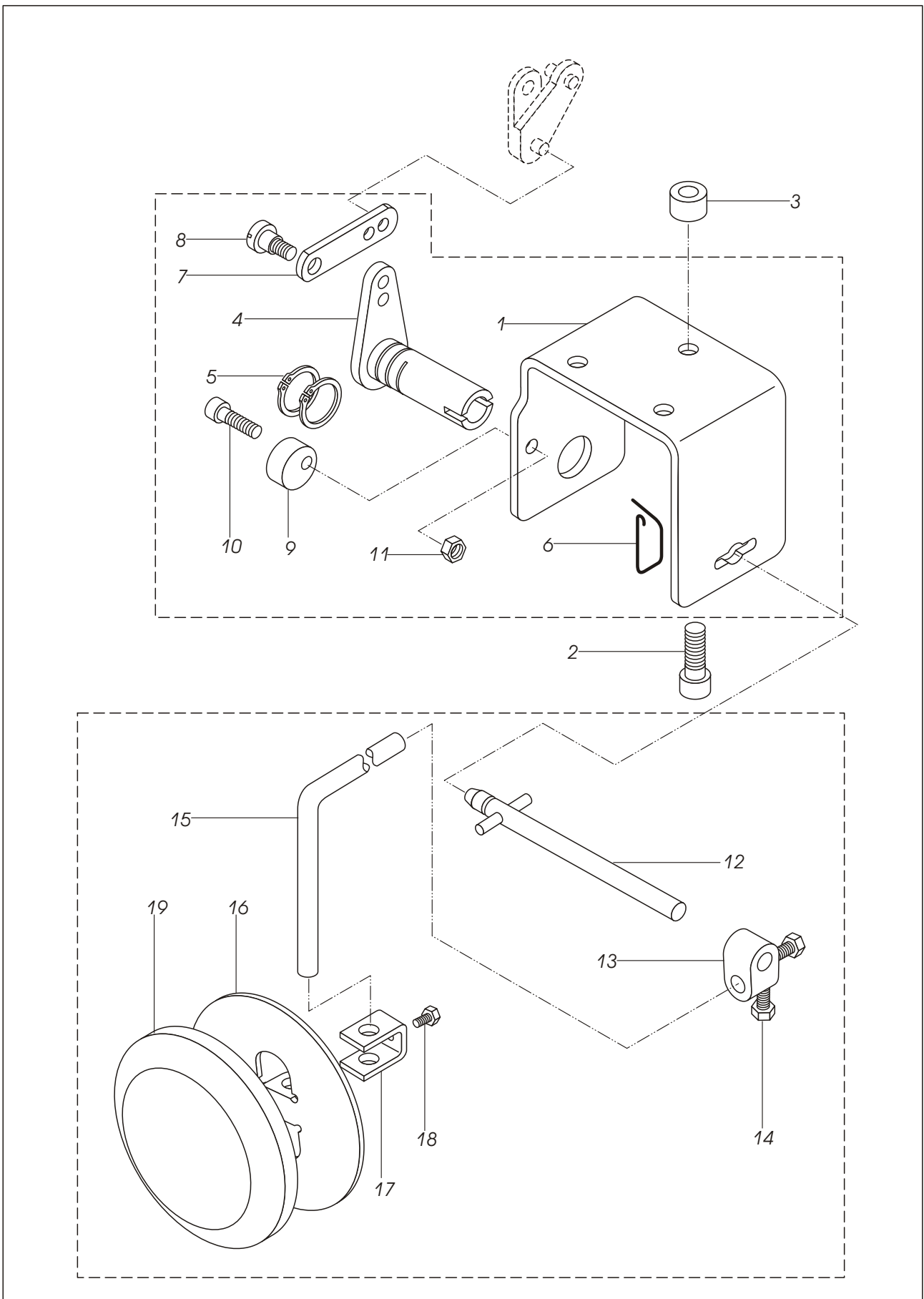

## 12. Knee lifter components

No .	Parts No .	Name	Qty.	Remarks
1	71WF4-025	Knee lifter bar bracket	1	
2		Screw	3	
3	71WF4-026	Washer	3	
4	71WF4-027	Knee lifter crank assembly	1	
5		Spring	2	
6	71WF4-028	Spring	1	
7	71WF4-029	Knee lifter crank link	1	
8	71WF4-030	Screw	1	GB70-M8 25
9	71WF4-031	Stop block	1	
10		Screw	1	
11		Nut	1	GB894.2-86 18
12	71WF6-001	Knee lifter shaft assembly	1	
13	71WF6-002	Knee lifter crank	1	
14	22T9-003B4	Screw	2	
15	22T9-003B2	Knee press bar	1	
16	22T9-003B5	Knee press plate	1	GB70-M6 20
17	22T9-003B6	Knee press rod bracket	1	GB6170-M6
18	22T9-003B7	Screw	1	
19	22T9-003B8	Knee press plate pad	1	SM5/16" 18

### 13. Binder Components

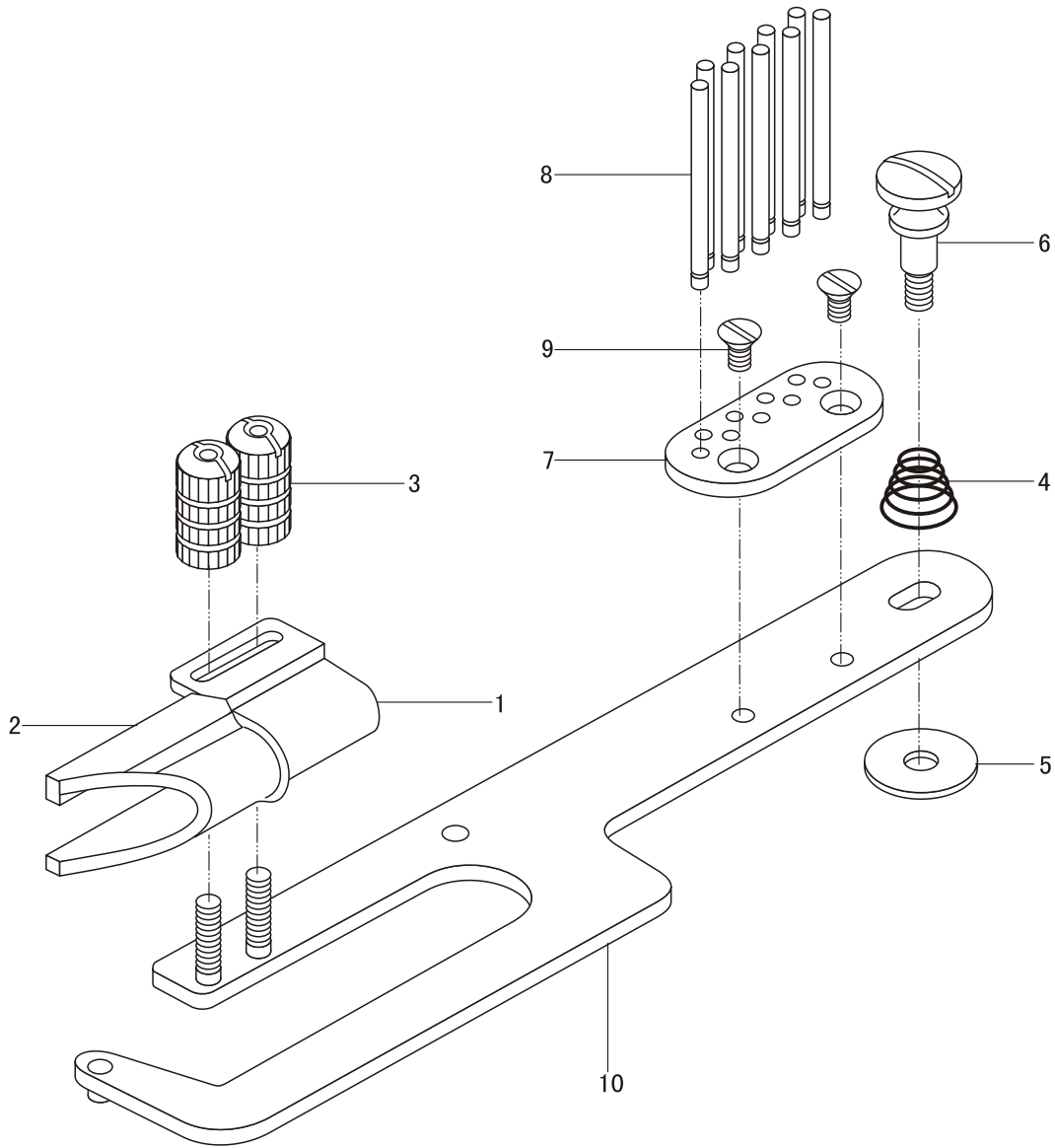



### 13. Binder Components

No .	Parts No .	Name	Qty.	Remarks
1	77WF7-007A	Base	1	
2	77WF7-007B	Cover	1	
3	77WF7-007C	Nut	2	
4	77WF7-008	Spring	1	
5	77WF7-009	Spacer	1	
6	77WF7-010	Screw	1	
7	77WF7-011A	Set plate	1	
8	77WF7-011B	Pin	9	
9	77WF7-011C	Screw	2	
10	77WF7-012	Bracket	1	

# 14. Accessories

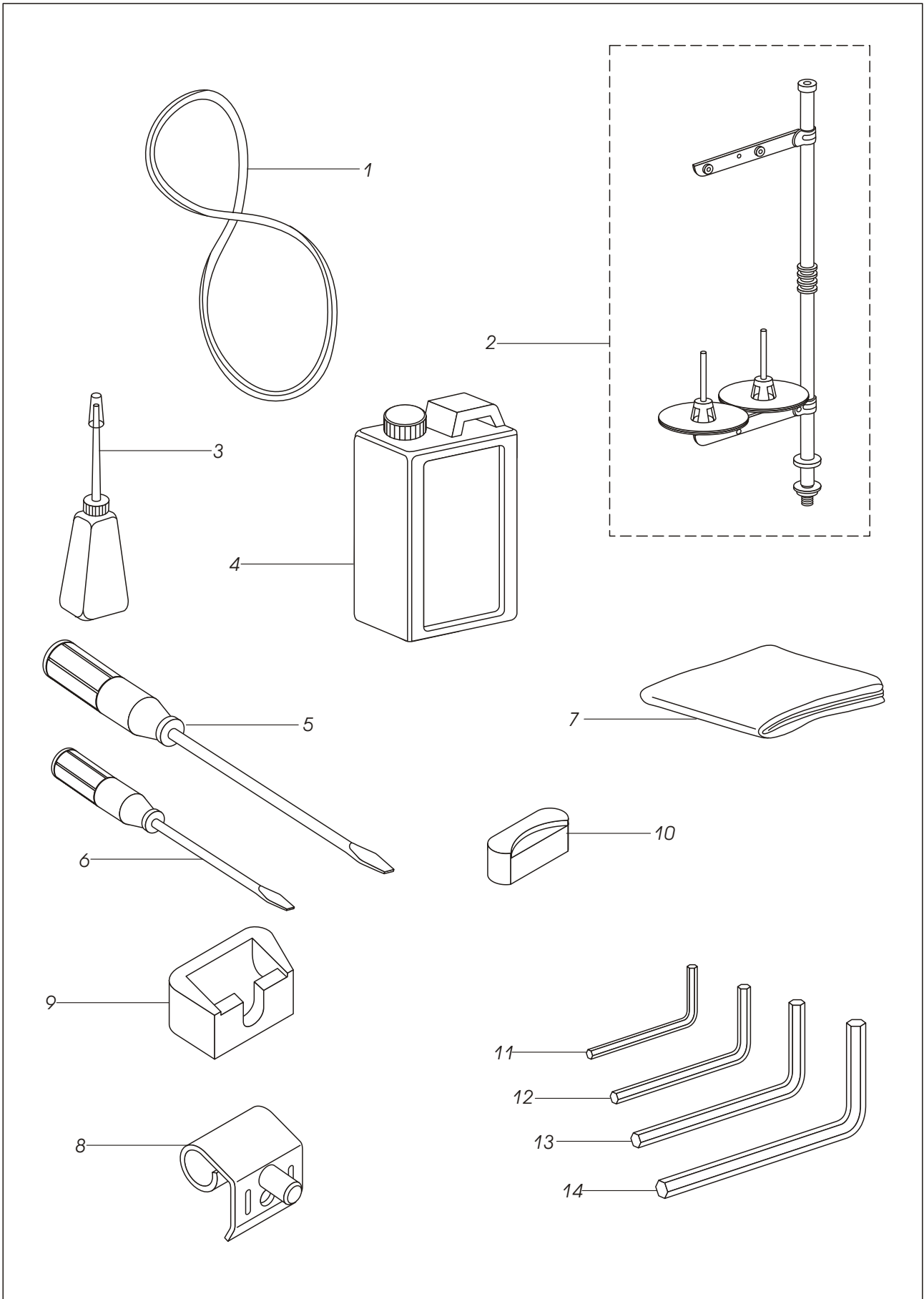

#### 14. Accessories

No .	Parts No .	Name	Qty.	Remarks
1		V-belt	1	
2	4F-007	Thread stand assembly	1	
3	33TF-011	Oil pot	1	
4	1F-009	Oil tank	1	
5	33TF-013	Screwdriver(middle)	1	
6	33TF-014	Screwdriver(small)	1	
7	1F-013	Machine head cover	1	
8	71WF5-009	Machine head hinge	2	
9	71WF5-010	Cushion	2	
10	71WF5-011	Rubber pad	2	
11		Hexagonal wrench	1	
12		Hexagonal wrench	1	
13		Hexagonal wrench	1	
14		Hexagonal wrench	1	

S=2.5mm  
 S=3mm  
 S=4mm  
 S=5mm

**TW1-1245**

**COMPOUND FEED LOCKSTITCH SEWING MACHINE**



**XI'AN TYPICAL EUROPE GmbH**

Hertelsbrunnenring 9

D-67657 Kaiserslautern

Tel.: +49 (0)631 316019-0

Fax: +49 (0)631 316019-11

E-mail: [sales@typical-europe.com](mailto:sales@typical-europe.com)

[www.typical-europe.com](http://www.typical-europe.com)